

DESIGN OF MINIATURIZED DUAL BAND MICROSTRIP PATCH ANTENNA ARRAY FOR WIRELESS LAN APPLICATION

N. VENKATA CHAITANYA¹

¹Asst. Professor, M. Tech, Department of Electronics and Communication Engineering, Vignan's Institute of Engineering for Women

D. LOHITHA², K. DIVYA VANI³, U. L. PRASANNA⁴, P.SANDHYA⁵

^{2,3,4,5} Department of Electronics and Communication Engineering, Vignan's Institute of Engineering for Women, Visakhapatnam-46, India

Abstract – The main objective of this paper is to design and simulate the miniaturized dual band microstrip patch antenna for WLAN applications. With the WLAN center frequencies 5.2GHz and 7GHz, we are observing the characteristics of antenna. In this paper we are using an FR_4 Epoxy material as a substrate which is having a dielectric constant 4.3 achieving a return loss of -10.24, VSWR as 1.88 and radiation pattern in double doughnut shape. The maximum gain obtained in dBm is 7.25. The proposed design has been calculated and results have been displayed by using High Frequency Structural Simulator (HFSS).

Keywords: WLAN, microstrip antenna, Return loss, Gain, VSWR

1. INTRODUCTION

Microstrip antenna is actually a very simple configuration, where we will be having only a ground plane and then we have a dielectric material whose dielectric constant is ϵ_r of substrate thickness 'h', and then there will be a patch which is printed on the other side of substrate. Here we are using a rectangular patch which is defined by its length, which actually determines the resonance frequency of the antenna; then by width. Infact if smaller is the width, lesser will be the radiation, larger is the width, larger will be radiation which

leads to larger bandwidth and larger gain. Here we are giving microstrip line feed where we connect this microstrip line to the patch. Since the patch antenna can be viewed as an open circuited transmission line, the voltage reflection coefficient will be 1. Patch arrays can provide much higher gain than a single patch at little additional cost, matching and phase adjustment can be performed.

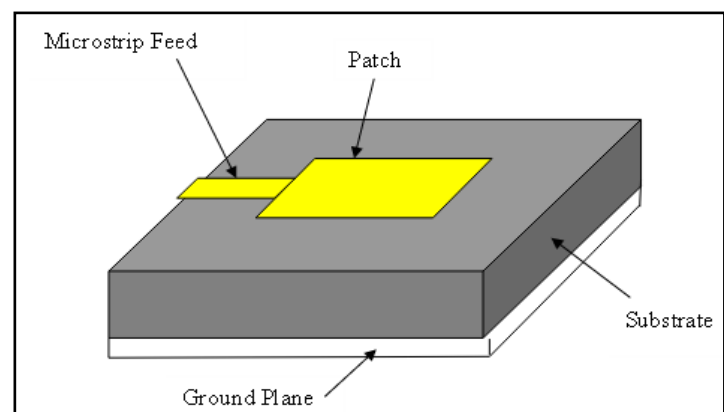

Fig-1: Microstrip Patch Antenna

1.1 ABOUT WLAN

A Wireless LAN (WLAN) is a wireless computer network that links to or more devices using wireless communication to form a local area network within a limited area. This gives users the ability to move around within the area and yet still

be connected to the network. Most modern WLANs are based on IEEE 802.11 standards and are marked under the Wi-Fi brand name. Users can access the internet from WLAN hotspots in restaurants, hotels and now with portable devices that connect to 3G or 4G networks. Often times this types of public access points require no registration or password to join a network. Others can be accessed once registration has occurred and/or a fee is paid.

1.1 MICROSTRIP ANTENNA IN WLAN

Modern implementations of WLANs range from small in-home networks to large, campus sized ones to completely mobile networks on aeroplanes and trains. One need to have an antenna to access the internet from WLAN and hence we need to use small size, low cost, light weight antenna for the extensive use of WLAN which is none other than microstrip antenna. A wireless LAN is ideal for certain work environment and can boost work efficiently levels in most cases. WLAN based spacecraft a receiving antenna with superior rejection to multipath signals is required. Multipath arises when the WLAN transmitted signal takes different paths to the receiving antenna. WLAN uses radio frequencies to transmit and receive data over air. The radiating patch and the feed lines are usually etched on dielectric substrate.

2. DESIGN EQUATION

The design antenna with FR-4 substrate is having the dielectric constant 4.3

Step1: Calculation of the width (w)-

$$W = \frac{c}{2f_0 \sqrt{\frac{\epsilon_r + 1}{2}}}$$

Step2: Calculation of actual length of the patch-

$$L = L_{eff} - 2\Delta L$$

Step3- Calculation of Effective dielectric constant-

$$\epsilon_e = \frac{\epsilon_r + 1}{2} + \frac{\epsilon_r - 1}{2} \left[1 + 12 \frac{h}{W} \right]^{-\frac{1}{2}}$$

h= thickness of substrate

Step4- Calculation of Effective length-

$$L_{eff} = \frac{c}{2f_0 \sqrt{\epsilon_{eff}}}$$

Step5- Calculation of the length extension-

$$\Delta L = 0.412h \frac{(\epsilon_{eff} + 0.3) \left(\frac{W}{h} + 0.264 \right)}{(\epsilon_{eff} - 0.258) \left(\frac{W}{h} + 0.8 \right)}$$

Step6- Calculation of resonant frequency-

$$f_0 = \frac{c}{2\sqrt{\epsilon_e} \left[\left(\frac{m}{L} \right)^2 + \left(\frac{n}{W} \right)^2 \right]^{\frac{1}{2}}}$$

ϵ_e = Effective dielectric constant

Table-1: Dimensions for dual patch MSA

| PARAMETERS | LENGTH(in mm) |
|----------------------|---------------|
| Length of patch 1 | 3.36 |
| Width of patch 1 | 4.105 |
| Length of patch 2 | 3.36/2 |
| Width of patch 2 | 4.105/2 |
| Length of edgefeed 1 | 1.8 |
| Width of edgefeed 1 | 0.783 |
| Length of feedline 1 | 2.007 |
| Width of feedline 1 | 0.304 |

3. SIMULATED RESULTS

After simulation the return loss, gain, voltage standing wave ratios are calculated.

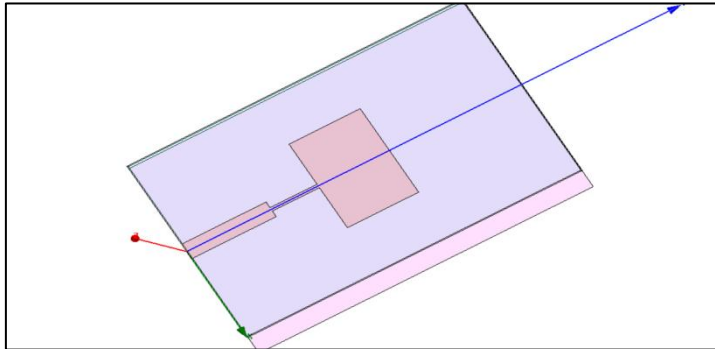

Fig-2: Design of single patch MSA

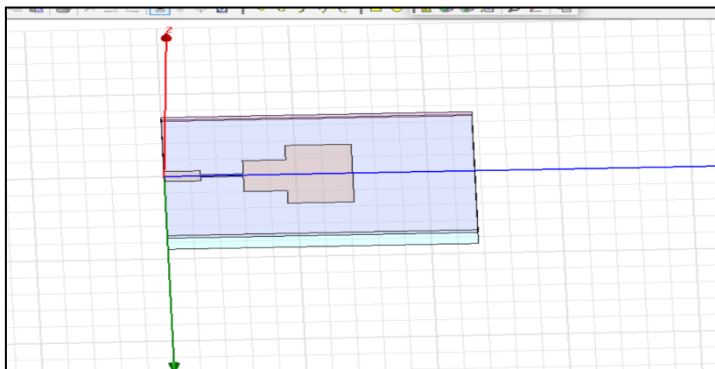

Fig-3 Design of double patch MSA

3.1 S PARAMETER

The electrical networks are characterized by S parameter are scattering parameter using matched impedances. In practice the most commonly quoted parameters in regards to antenna is S11. S11 represents how much power is reflected from antenna. Hence S11 is known as reflection coefficient of return loss. If S11=0 dB then all the power is reflected from the antenna.

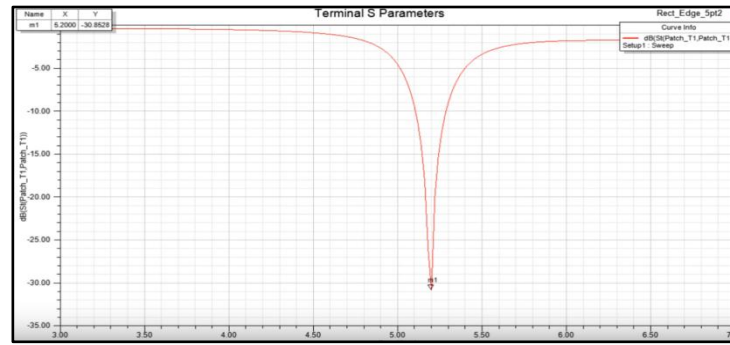

Fig-4: S11 parameter of single patch MSA

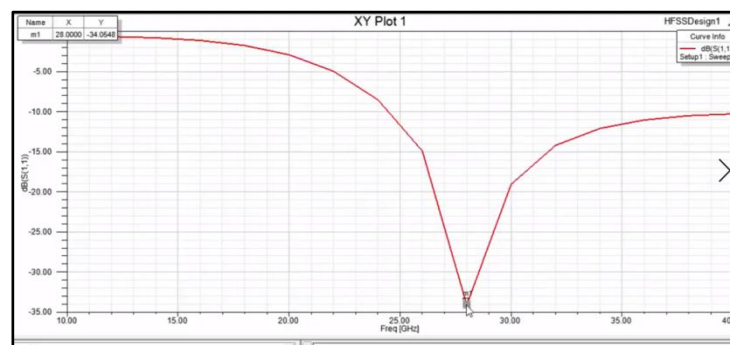

Fig-5: S11 parameter of dual patch MSA

3.2 VOLTAGE STANDING WAVE RATIO

Voltage standing wave ratio (VSWR) is a measurement that describes the impedance matching of the antenna to the ratio or transmission line connected to it.

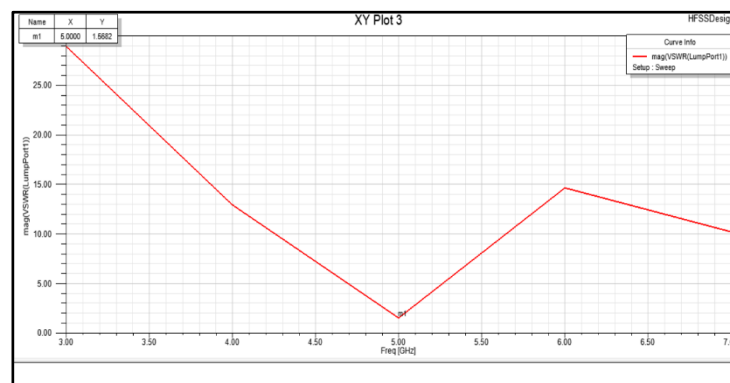

Fig-6: VSWR of single patch MSA

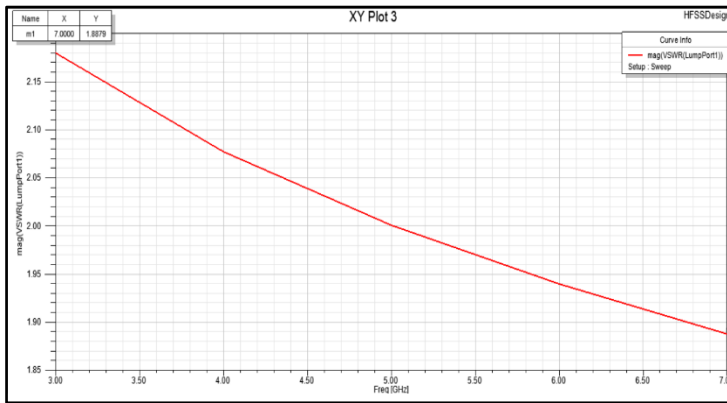

Fig-7: VSWR of dual patch MSA

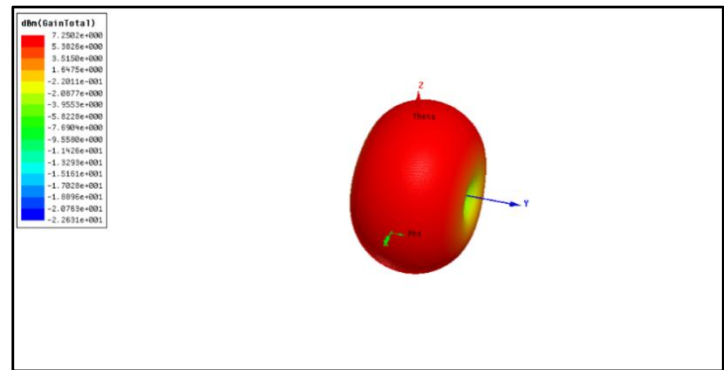

Fig-10: Gain of dual patch MSA : 7.25

3.3 Gain

Gain is the conversion of input power into radio waves in a particular directional

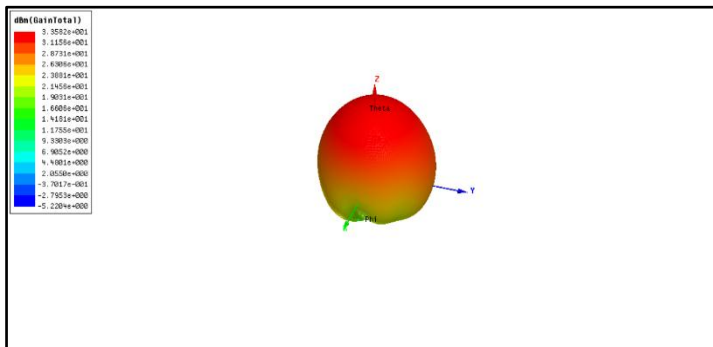

Fig-8: Gain of single patch MSA: 3.35

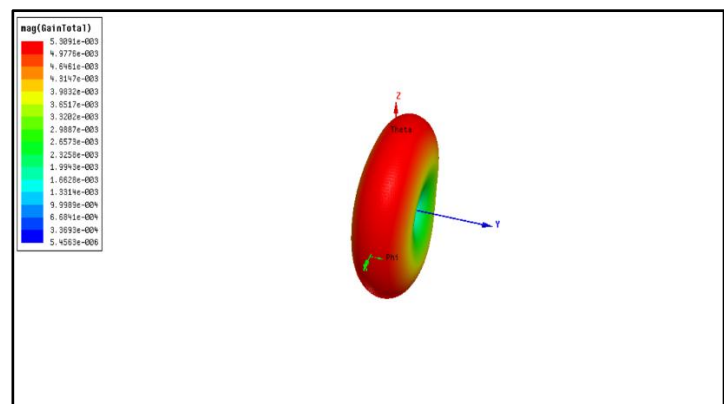

Fig-11: Gain of dual patch MSA: 5.30

The different characteristics of antenna having different patches are shown above. The gain of single patch MSA is observed to be 3.35dBm where as the gain of dual patch MSA is 7.25dBm. A wireless LAN is ideal for certain work environment and can boost work efficiently levels in most cases. WLAN based spacecraft a receiving antenna with superior rejection to multipath signals is required.

Table-2 : Summary Results

| Parameters | For single patch MSA | For dual patch MSA |
|-------------|----------------------|--------------------|
| Return loss | -30.82dB | -34.05dB |
| VSWR | 1.56 | 1.88 |
| Gain(in dB) | 3.35 | 7.25 |
| Substrate | FR4 | FR4 |

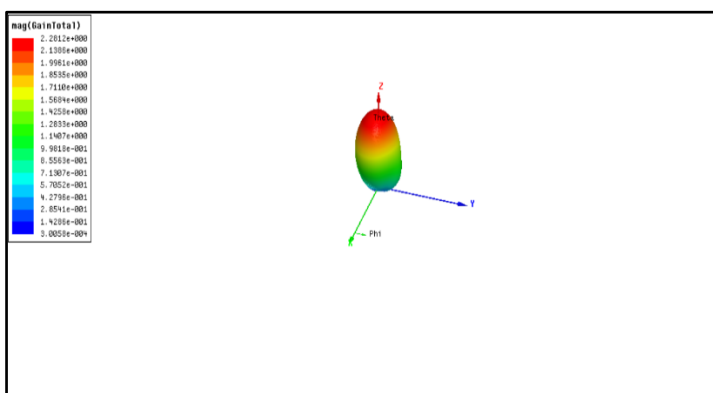

Fig-9: Gain of single patch MSA: 2.20

4. CONCLUSION

This paper represents the design and analysis of dual band Microstrip patch antenna at resonant frequencies of 5.2GHz and 7GHz. The simulation is done by using HFSS. The VSWR should be in the range of 1-2 for good performance of the antenna. We obtained VSWR of 1.88 and achieved a gain of 7.25dB and return loss of -10.24. The two designed antennas have a higher gain and a favourable transmission characteristic in the operating band, which is in accordance with the requirements of WLAN communication under more complicated conditions.

5. REFERENCES

- [1] Ka Ming Mak ; Hau Wah Lai; Kwai Man Luk; Chi Hou Chan, "Circularly Polarized Patch Antenna for Future 5G Mobile Phones," in *Access*, IEEE, vol.2, no., pp.1521-1529, 2014.
- [2] *Antenna Theory*, C.Balanis, Wiley, 2nd edition (1997), Chapter 14. ISBN 0- 471-59268-4.
- [3] Asrokin, A.Rahim, M.K.A. Aziz, M.Z.A.A."Dual band microstrip antenna for wireless LAN application," *Applied Electromagnetics*, 2005. APACE 2005. Asia-Pacific Conference on, vol., no., pp.4 pp., 20-21 Dec. 2005
- [4] Y. Cao, C. Lu, and Y. Zhang, "A compact dual band miniaturized antenna for WLAN operation," in *Proc. ICMMT*, Apr. 2008, pp. 416–419.
- [5] Richards, W.F., S.E. Davidson, and S.A. Long, "Dual band reactively loaded microstrip antenna," *IEEE Trans. Ant. Prop.*, Vol. AP-33, No.5, 556-561, 1985.
- [6]. D.M.Pozar, "Microstrip antenna aperture-coupled to a microstrip line," *Electron. Lett.*, vol.21, no.2, pp.49-50.
- [7] Khodabakhshi H., Cheldavi A. Irradiation of a six-layered spherical model of human head in the near field of a half-wave dipole antenna. *IEEE Trans. Microw. Theory Tech.* 2010;58:680–690. doi: 10.1109/TMTT.2010.2040410.
- [8] Wang Z., Lee L.Z., Psychoudakis D., Volakis J.L. Embroidered multiband body-worn antenna for GSM/PCS/WLAN communications. *IEEE Trans. Antennas Propag.* 2014;62:3321–3329. doi: 10.1109/TAP.2014.2314311.