

MAXIMUM POWER POINT TRACKING FROM PV PANEL USING FUZZY LOGIC CONTROLLER

Ms. Chandla Ellis¹, Giritharan V I², Karthikeyan D³ Kamesh J⁴, D. John Durai⁵

¹Associate Professor, EEE Department, R.M.K. Engineering College, Kavaraipettai, Tamilnadu, India.

²Final year Student, EEE Department, R.M.K. Engineering College, Kavaraipettai, Tamilnadu, India.

³Final year Student, EEE Department, R.M.K. Engineering College, Kavaraipettai, Tamilnadu, India.

⁴Final year Student, EEE Department, R.M.K. Engineering College, Kavaraipettai, Tamilnadu, India.

⁵Manager Technical Services, SIPA INDIA PVT. LTD, Tamilnadu, India.

Abstract – Presently, the world is meeting energy crisis due to population inflation over the period of last few decades and with the depletion of the energy resources, the demand has increased eventually to a higher rate. In order to eradicate this major problem, renewable energy sources are employed where solar energy extraction plays a vital role in electrification of cities and towns. However, the efficiency of the power extraction from panel over a period of time is small and is about 18%. A mono crystalline Silicon cells are arranged in series and parallel connection to deliver a desired power required by load. Thus, maximum power is tracked using fuzzy logic controller from the PV panel to improve its efficiency such the peak power is constantly supplied to the load maintaining constant load voltage. By tracking maximum power from the panel, increases improves its life expectancy rate. The usage of fuzzy logic controller under non-linear condition improves the voltage and power accuracy at the load side by properly providing duty cycle ratio to the gate terminal of the boost converter for that particular input voltage. The open loop control of the converter elucidates the gain characteristics of the same. By implementing closed loop technology, the output voltage is maintained at the load side by transferring maximum power tracked to the load. A 1.1 kW boost converter and PV panel is designed.

Key Words: Boost Converter, Maximum Power-Point tracking, PV Panel, Fuzzy logic controller.

1. INTRODUCTION

The renewable energy sources are rapidly gets deployed in an inefficient manner in terms of energy, cost and power extraction. Thus, the operating period of the system has to be utilized in a better way than the conventional procedure of extracting the power delivered by the source. So, the maximum power point tracking is employed where the peak power is transferred to the load using various algorithms [1], [3], [4]. [6] and [7]. The PV

array has to be designed in such a way that it must have the peak power slightly more than the demand power, as it has supply the losses in the system too [5], [14], [15] and [17].

The boost converter design for the particular PV source is an important technology and the modelling of the same is done and to be validated [2], [8], [9] and [12]. Finally, the designed and validated model are interfaced and the characteristics are studied under open loop and closed loop condition.

1.1 EXISTING MODEL

The present model which is available in the market involves the implementation of MPPT (Maximum Power Point tracking) algorithms in fuzzy logic controller is time consuming and largely oscillates between the peak voltage value and eventually the peak power too oscillates between the peak value. Moreover, the inputs to the fuzzy system is error signal and change in error signal, which decides the change in output duty cycle or actual duty ratio.

1.2 PROPOSED MODEL

The proposed algorithm for power extraction using fuzzy logic controller is less time consuming when compared to the existing model that is currently available. Besides, the proposed algorithm makes the output voltage and power makes the oscillation damped and settle to a particular peak voltage and power at the load side within minimal amount of time interval. The duty cycle designed using the algorithm is more accurate with the error range of $\pm 0.4\%$.

2. DESIGN OF PV SYSTEM

A 1.1 kW PV panel is designed to supply the peak power to the load. Being pv panel a current source, the number of series cells and parallel cells are designed to be 60 and 4 respectively.

Table -1: PV System Design

Design of PV Module	
Series cells number Ns	60
Parallel connected cells Np	4
Short Circuit current Iscr	29 A
Reference Temperature	25 °C
Open circuit voltage	36.83 V

Table – 1 shows the design metrics for the PV panel to deliver peak power of 1.1 kW to the load. Figure 2.1 shows the I-V and P-V typical characteristics of the PV panel and the peak power delivered to be 1.1 kW at 30V and 16.5 A.

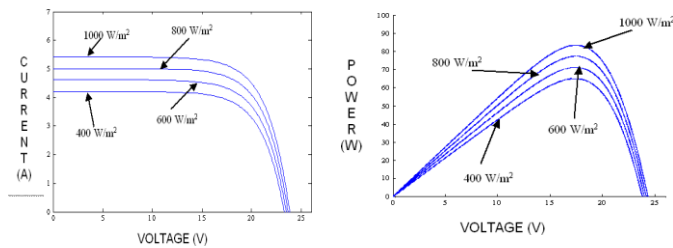

Fig-2.1: Typical I-V and P-V curves for PV panel for different irradiances.

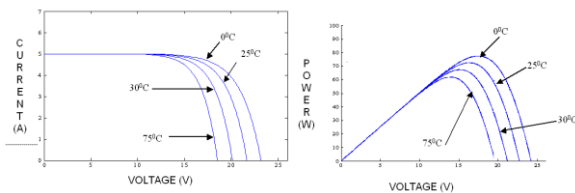

Fig-2.2: Typical I-V and P-V curves for PV panel for different temperature

The efficiency of PV Panel is given by the following formula,

$$\text{Efficiency} = \frac{V_{mp} \cdot I_{mp}}{V_{oc} \cdot I_{sc}}$$

The output current from the PV source is given by the following expression:

$$I = I_{ph} - I_0 \cdot \exp\left(\frac{V + I \cdot R_s}{V_t} - 1\right) + \left[\frac{V + I \cdot R_s}{R_p}\right]$$

Where I_{ph} is the photo current

V is the output voltage

R_s and R_p is series and parallel resistances.

3. FUZZY LOGIC CONTROLLER

Fuzzy logic controller is a popular method of tracking maximum power from the PV array during non-linear and uncertain input conditions. Thus it is well suited for installation in PV application for transferring maximum power to the load. The input to the fuzzy controller is voltage value and the output is duty cycle. The further approximation is achieved using the same fuzzy controller logic. Thus, highly efficient system is designed for duty cycle input to the converter for particular input voltage.

The Membership function representation of input and output parameters are designated and it is shown in fig-2.3 and 2.4.

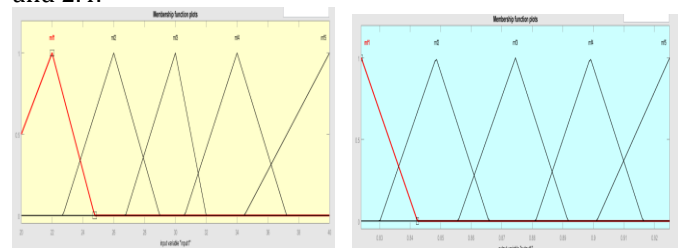

Fig-2.3 : Membership representation of the input parameters

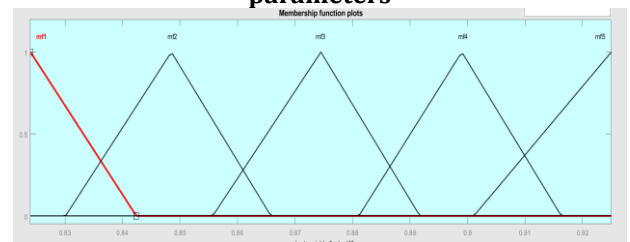

Fig-2.4 : Membership representation of the input parameters

	NB	NS	Z	PS	PB
NB	PB	PB	PB	NB	NB
NS	PS	PB	PS	NS	NS
Z	PB	Z	Z	NS	NB
PS	Z	PS	NS	NS	NB
PB	PB	PS	NS	NB	NB

Table – 1: Fuzzy Logic Diagram

Table 1 shows the fuzzy logic diagram for the calculation of output duty ratio. The duty ratio are in the range of 0.8 to 0.92 and it is arranged in ascending order. Suppose that the input voltage in NB, then the duty cycle should be in PB.

4. BOOST CONVERTER DESIGN

A 1.1 kW boost converter is designed and the metrics designed is tabulated as shown in the table 2. Fig-2.1 shows the basic circuit model of the boost converter.

Fig-3.1 Boost converter circuit diagram

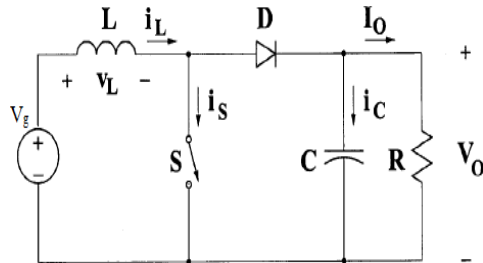

Fig-3.2 shows the typical waveforms of the boost converter for the designed specifications.

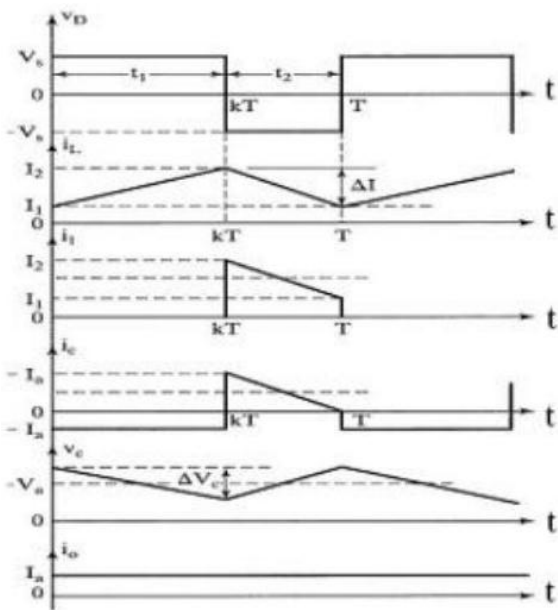

Fig-3.2: Boost Converter typical waveforms

Parameters	Values
Inductance L	0.0296 H
Capacitance C	1.5 e-5 F
Resistance R	55 ohms

Table -2 : Boost converter design parameters

The open loop performance of the boost converter is validated and in order to maintain the voltage and transfer the peak power to the load side, the feedback controller is implemented. The closed loop path technology in boost converter is fulfilled by the employment of fuzzy logic controller.

5. INTERFACING PV SOURCE WITH BOOST CONVERTER

The pv source output terminals is connected to the boost converter via a coupling capacitor of 100 micro farad. This capacitor is necessary as the pv

source is a current source and the boost converter input to be fed from voltage source. Thus, this capacitor plays a vital role in pushing the power to the boost converter from PV source. Fig 5.1 shows the interface diagram of the pv source with the boost converter.

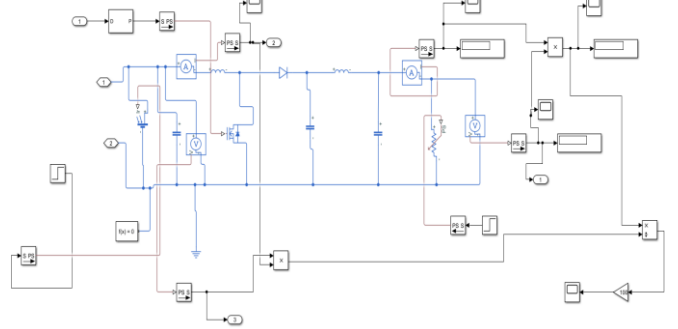

Fig-5.1: PV interface with the boost converter

The employment of the LC filter in the boost converter reduces the ripple voltage percent from 5% to 2.3%. Thus by varying the resistive load at the output side, maximum power is transferred from source to the load.

6. SIMULATION RESULTS AND DISCUSSIONS

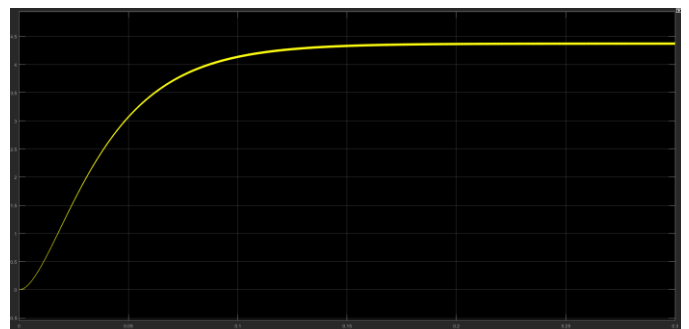

Fig 6.1: output current Vs time

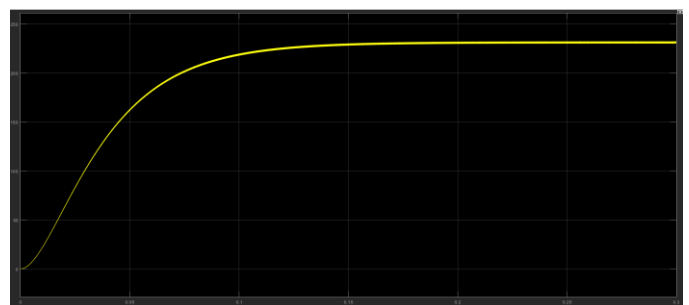

Fig 6.2: output Voltage Vs time

From figures 6.1 and 6.2, it is clearly shown that the output voltage and the current is maintained 230 V and 4.56 A respectively. Thus 1.08 kW of peak power is transferred from the source to the load. Figure 6.3 shows

the efficiency plot of the system with an average efficiency of 98.5%.

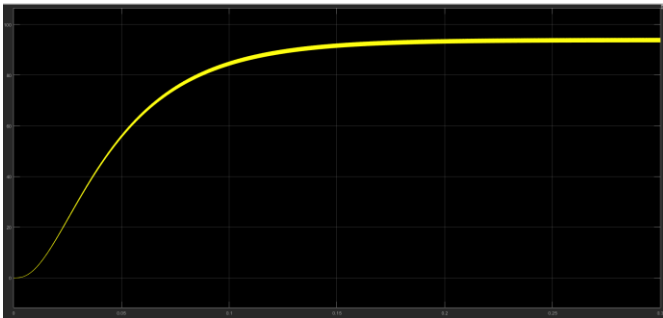

Fig-6.3: Efficiency Vs time

7. CONCLUSION

The proposed model of the system is designed using fuzzy logic controller and is validated. The efficiency of the system performance is averaged around 98.5% with the time consumption reduced to around 96%. By implementing the concept, the output voltage is reliable and certain even for non-linear and uncertain input conditions. With the aid of proposed algorithm, the output voltage is maintained at 230 Volts with error of ± 0.4 V. This model is only applicable to the input voltage range of 20 V to 50 V to the boost converter.

8. ACKNOWLEDGEMENT

We wish to express our deep sense of gratitude and indebtedness to **Ms. Chandla Ellis**, Associate Professor, Department of Electrical and Electronics Engineering, R.M.K Engineering College, for introducing the present topic and for their inspiring guidance, constructive criticism and valuable suggestion throughout this project work.

Our sincere thanks to all our friends who have patiently extended all sorts of help for accomplishing this undertaking.

9. REFERENCES

- [1] I.H Atlas, A.M Sharaf, "A photovoltaic Array Simulation Model for Matlab- Simulink GUI Environment", Process. of IEEE International Conference on Clean Electrical Power, ICCEP 2007, Capri, Italy.
- [2] Jesus Leyva-Ramos, Member, IEEE, and Jorge Alberto Morales-Saldana, "A design criteria for the current gain in Current Programmed Regulators", IEEE Transactions on industrial electronics, Vol. 45, No. 4, August 1998.
- [3] K.H. Hussein, I. Muta, T. Hoshino, M. Osakada, "Maximum photovoltaic power tracking: an algorithm for rapidly changing atmospheric conditions", IEE Proc.- Gener. Trans. Distrib., Vol. 142, No. 1, January 1995.
- [4] Md. Rabiul Islam, Youguang Guo, Jian Guo Zhu, M.G

Rabbani, "Simulation of PV Array Characteristics and Fabrication of Microcontroller Based MPPT", Faculty of Engineering and Information technology, University of Technology Sydney, Australia, 6th International Conference on Electrical and Computer Engineering ICECE 2010, 18-20 December 2010, Dhaka, Bangladesh.

- [5] W. Xiao, W. G. Dunford, and A. Capel, "A novel modeling method for photovoltaic cells", in Proc. IEEE 35th Annu. Power Electron. Spec. Conf. (PESC), 2004, vol. 3, pp. 1950-1956.
- [6] IEEE Standard Definitions of Terms for Solar Cells, 1969.
- [7] Oliva Mah NSPRI, "Fundamentals of Photovoltaic Materials", National Solar power institute, Inc. 12/21/98.
- [8] Muhammad H. Rashid, "Power Electronics Circuits, Devices and Applications", Third Edition.
- [9] Modelling and Control design for DC-DC converter, Power Management group, AVLSI Lab, IIT-Kharagpur.
- [10] Nielsen, R. 2005, 'Solar Radiation', <http://home.iprimus.com.au/nielsens/>
- [11] www.earthscan.co.uk/Portals/
- [12] Application of non-conventional & renewable energy sources, Bureau of Energy Efficiency.
- [13] http://en.wikipedia.org/wiki/Solar_power
- [14] http://en.wikipedia.org/wiki/Photovoltaic_system
- [15] http://en.wikipedia.org/wiki/Solar_panel
- [16] <http://www.blueplanet-energy.com/images/solar/PV-cell-module-array.gif/>
- [17] http://www.rids-nepal.org/index.php/Solar_Photo_Voltaic.html