

SOLAR POWERD WATER SURFACE GARBAGE COLLECTING BOAT

Ketan H. Pakhmode¹, Ronit R. Dudhe², Gangadhar S. Waghmare³, Daniyal A. Kamble⁴,
Kirti Dhenge⁵

^{1,2,3,4}Student, Dept. of Electrical Engineering, KDK College of Engineering Nagpur, Maharashtra, India

⁵Faculty, Dept. of Electrical Engineering, KDK College of Engineering Nagpur, Maharashtra, India

ABSTRACT:- As we know the population of India increasing day by day and due to this the pollution also gets increase. The garbage which are produced by the people are the main cause of pollution. The most of the garbage are dumped or just thrown in the lake, river or other water resources. The garbage which are thrown in the water such as lakes, rivers and other water resources due to which the water gets polluted because of which we cannot use that water for our daily use and the water will also get wasted. In many of cities of India this is the major problem. To overcome this water pollution our project "Solar powered water surface cleaning boat" is very helpful by collecting the garbage which are floating on the surface of water. This project is working automatically and saves the manpower. This project is also very efficient and work on the solar energy no external power supply is required. A battery of 12v is used to store the energy which is collected by the solar plate, then this battery will use this stored energy to operate the complete boat.

Keywords:- Battery, solar energy, wireless communication, garbage collector, water impurities, conveyor belt, PMDC motor.

1. INTRODUCTION

Water is the most important resource for the living things. So that the cleanliness of water is the basic need. But water in the lake or river is getting polluted by the humans. Our project tries to get

Overcome this water pollution and clean the water, which can be very useful for the living things. Also our project has the potential to become a great security advantage if it will be used wisely.

The boat totally works on solar power, which is free of cost. This boat will not require any external supply of energy so it saves the money. In day time the boat will store the energy with the help of sun rays which are falling on the solar panel and at night time the boat will start working and collect the garbage. The

Main advantage of working at night time is the fewer crowds. In this way we support to "The Swatchha Bharat Abhiyan".

II. STANDARD APPLIED

The standard being applied is IEEE STD 1621™-2004(R2009) "IEEE Standard for User Interface Elements in Power Control Electronic Devices Employed in Office/Consumer Environments" for the design and fabrication of "Smart Water Cleaning Robot". IEEE Standard 1621 enabled authors to learn and implement basic power & control mechanism for subject robot, thus making it user friendly. The mode of implementation of IEEE standard 1621 is discussed in detail in later section.

III. LITERATURE SURVEY

When the idea of such a device came into our mind, we searched for the counter measures that can be implemented to limit the water pollution due to floating waste. As the issue is related to the environment and pollution has been responsible for very drastic changes in the environment we started searching for various environment related journals to find any relevant information.

1. Garbage collection robot on the beach using wireless communication:

This article presents the garbage collection robot on the beach using wireless communication. The robot is built on caterpillar wheels, size 52x74x17 cm and power is supplied from 12 v 30Ah battery which is connected to 40 W solar cells. The user can control a robot via a program developed from Visual Basic 2005 application based on Windows XP. The command from user sent via Bluetooth to PIC18F4550 for processing. In addition, it is also equipped with an IP camera with added pan/tilt capability which relays feedback information to the human operator. The result of robot performance where found that the robot can move with the average speed of 0.5 meter per sec. on the sand via wireless communication and collect the big garbage with side 12.5x49 cm.

2. Autonomous garbage collector robot

This paper presents the garbage collector robot for footpath using Arduino microcontroller. The robot is built on a metallic base of size 50x40 cm. which is powered by battery of 12v, 7.5Ah. The robot movement is controlled by

programming the arduino. The robot is design to collect garbage at footpath, public places (parks, school, and colleges), mostly cemented path and beach. The robot cannot be used on muddy surface. The robot is built in such a way that, when it is started it will move on the path defined in the program. When it encounters the obstacle, depending on condition applied in the program the bot proceeds with further motion and then robot peaks up the garbage.

IV. COMPONENTS

A. CONVEYOR

It is a process where the raw materials and products are transport from one manufacturing stage to another. This is design such that they are safe loading, easy to handle, cheap, fast.

This belt carries garbage from water bodies to the container. This belt consists of two pulleys which are powered by dc motor of 30rpm, 600mA.Length 76.2 cm, width 30.40 cm.

B. PIPES

Polyvinyl chloride (PVC) is synthetic plastic polymer. These pipes are air enclosed. Pipes are used as a base of model (boat).Pipes size- diameter 11cm, length 106.68 cm, width 50.8 cm. this pipes does not corrode.

C. PROPELLER

It is a type of fan that transmits power by converting rotational motion into thrust. A propeller work by accelerating water backward. propeller is used for movement of boat .two propellers are required for motion (left and right turning).the diameter of propeller is 6cm and run by two dc motors of rating 1000rpm,600mA.

D. PMDC MOTORS

Permanent magnet Dc motor(PMDC),provide magnetic field instead of stator winding, which provide reduction in speed which gives constant speed for rotation of conveyor.

Conveyor belt having two PMDC motor of rating 30rpm, 600mA. Other two motors are used for propellers (6cm diameter) i.e. thrust motor having 1000rpm, 600mA.

E. SOLAR PANEL

Solar panel is use for charging the battery. Sunrays incident on the panel and it gets converted into electricity in this process the light energy is change into electrical energy. The dimensions of solar panel are 220*360*20mm.The voltage rating of solar panel is 12v.solar panel is used because it is harmless Or environment and it reduces fuel cost. No external supply of electricity is required.

F. ARDUINO NANO

Arduino Nano 3.0 (ATmega328P) the programming can be done using embedded c++. Arduino nano can be powered via much USB connection. It required 5v regulated external power supply. It is small and cheaper. Each pin can provide or receive a maximum of 40mA.



G. BLUETOOTH MODULE

HC-05, version2.08 module is an easy to use Bluetooth module. The range of module is 15m-20m.It is controlled by our mobile phone with the help of specific application i.e. Bluetooth controller. It is easily available in market i.e., HC-04, HC-06.The cost of this module is less and efficient as compare to others.

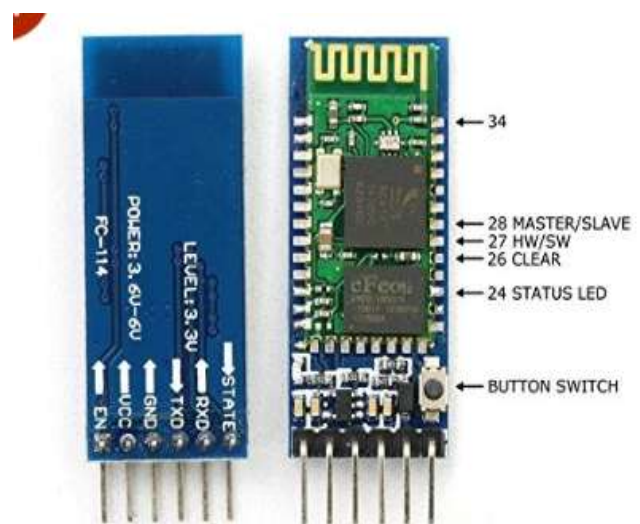

H. SENSORS

Sensors are the device that used to detect and response to the electrical and optical signal.

Ultrasonic sensors: Ultrasonic sensors consist of two categories i.e., transmitter and receiver. Transmitter converts electrical signal into sound and receiver converts sound into electrical signal.

Two sensors are used, one is used for detecting the obstacles and garbage another is used for sensing the level of garbage container.



V. BLOCK DIAGRAM AND WORKING:

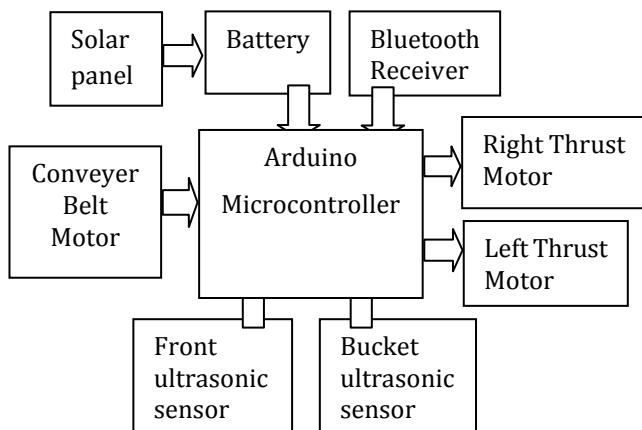

The sun rays incident on solar panel and it convert light energy to electrical energy. This generated energy is stored into the battery, the supply is taken from battery to all electronics and electrical devices. The arduino is the microcontroller it is programmed that it will give command to change the motion of the boat, rotation of conveyer belt etc.

This boat will totally work by solar energy so no external power supply is required.

The Bluetooth module is connected to the arduino and which can be operated by using mobile app i.e. Bluetooth controller app. or any other application download from internet.

The four motors will operate as it receives the command from arduino.

The ultrasonic sensors will detect the obstacles using transmitting and receiving signal which send this signal to arduino. Arduino give command to motors and then to conveyor and propeller.

Then conveyor will start rotating which will collect the garbage through water. The conveyor belt will transfer the garbage to garbage container. The container also consists of ultrasonic sensor which will sense the level of garbage. As the garbage increased beyond the level it will give signal to arduino which will give command to motors to stop collecting the garbage by conveyor belt.

The standby time of the battery is 2-3 hours in night. We can increase the working hours as per our requirement by increasing the size of battery.

VI. CONCLUSION

The ship can prove to be a helping hand in controlling the increasing problem of water pollution. It can greatly reduce the problems caused by floating waste. Also it can be effectively used for the surveillance purpose and can be used as a good security equipment.

VII. REFERENCES

[1]Sirichaiwatanasophon and sarineeonitrakul," Garbage collection robot on the beach using wireless communication", international conference on informatics, environment, energy & application IPCBEE.

[2]"Apoorva S. Chaithanya, Rukuma S. Prabhu, Saiswaroop B. Shetty, DenitaD'Souza",Autonomous Garbage Collector Robot, Department of Electrical & Electronics Engineering, St Joseph Engineering College, Mangaluru, India .