

Wireless Notice Board using Raspberry Pi

Mrs. C. Preethibha M.E.¹, Dhanasekar. L², John Rencinapreethi. S³, Madhan Kumar⁴, Sweatha. S⁵

¹Assistant Professor, Department of Electronics and Communication Engineering, Park College of Engineering and Technology, Tamil Nadu, India.

^{2,3,4,5}Students, Department of Electronics and Communication Engineering, Park College of Engineering and Technology, Tamil Nadu, India.

Abstract - The main aim of this project is to develop a wireless notice board for displaying the announcements and notices. It is a smart board developed as user friendly notice board with wireless concept that offers the flexibility to control the notice board. This notice board is made to overcome the messy wiring of earlier electronic wired model. It's objective is to increase the speed of communication, saving time and resources.

Key Words: Raspberry Pi, LCD, Raspbian, Android app, Google Firebase

1. INTRODUCTION

Notice board plays a vital role in displaying the message up-to-day. The main aim of this paper is to present a reliable notice board with low cost. The LCD display is connected with Raspberry Pi to display the message. Here an Android app is developed by which a number of authenticated users can access through this app and send messages from anywhere. The message will be displayed on the screen by the web server. The Android app is developed using MIT App inventor. It provides a great platform in the path of digitalization.

2. LITERATURE SURVEY

Neeraj Khara and Divya Shukla, IEEE 2016[2] has developed an Android based wireless notice board. Their proposed system uses Bluetooth based wireless serial data communication. For this purpose android based application programs for Bluetooth communication between Android based personal assistant devices and wireless display boards are used. A low cost microcontroller board (Arduino Uno) is programmed to receive and display messages. But they can be accessed for short distances. Dharmendra Kumar Sharma and Vineet Tiwari, IEEE 2015[1] introduces a handheld wireless electronic notice board by using Atmel's ATmega32 microcontroller, Bluetooth and Zig-Bee. Their performance was analyzed based on the parameters such as range, BER (bit error rate), RSSI (Received signal strength indicator), power consumption and signal attenuation. The board

receives information from wireless receiver in a serial manner and displays it on the graphical liquid display. From the survey made above we came to a conclusion that a notice board must be developed with simple kits and in low cost. We have realized a common communication receiver having compatibility with both wireless modules i.e. Wi-Fi.

3. EXISTING SYSTEM

In early days GSM technology is used for displaying information. Here GSM module is used to receive information from the user. In this work only one message can be transferred. It also displays only the text messages. Hence we cannot transfer other than text messages. By the introduction of Bluetooth technology communications become faster. In this technology, an android application is used for sending messages. It includes cable replacement and data can be sent up to the rate of 1 Mb per sec. Bluetooth also has limited range of 70 m to 100 m approximately. To increase the range of communication Zig-Bee based notice boards are introduced. But here data rate is only about 250 Kb per sec.

4. PROPOSED SYSTEM

The operation of wireless notice board is that when a user sends a message through the Android app that data is received by Raspberry Pi which is with Wi-Fi connection. The Raspbian OS is installed in SD card. The Android app is developed using the MIT App Inventor. The app is first installed in the user's mobile phone. The MIT App Inventor creates a Google Firebase account wherein we can store the data. The data can be accessed using My SQL and by Python programming. The web link is developed to connect the Android app and LCD display. The Raspberry Pi is connected to the LCD display using the HDMI cable. The message sent by the user is retrieved to LCD display through HDMI cable. It displays the message with user name and ID. In this setup we can also send the videos. The data displayed on screen are stored in Excel Sheet for future reference. Thus it is very useful for the faculty members.

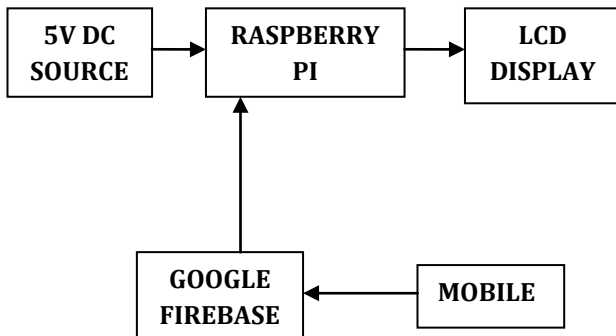

Fig-1: Block Diagram of Wireless Notice Board using Raspberry Pi

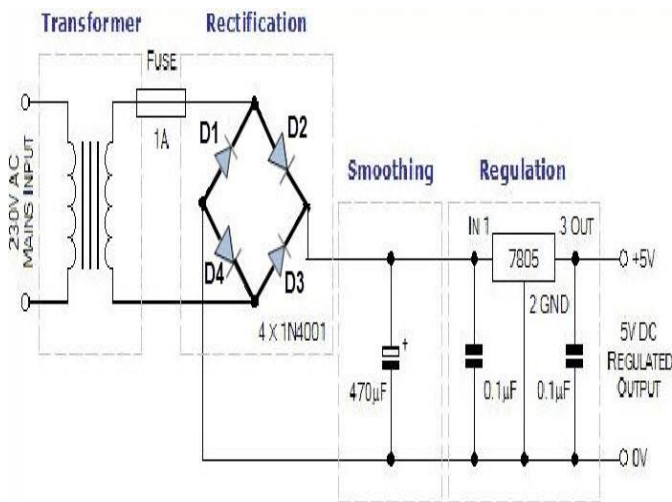

Fig-2: Power Source

5. COMPONENTS DESCRIPTION

5.1 Raspberry Pi: The Raspberry Pi is a series of small single-board computer used to promote teaching of basic computer science in schools and in developing countries. The peripherals such as mouse and keyboard are not included.

5.2 Speed and Memory: Processor speed ranges from 700 MHz to 1.4 GHz. The memory ranges from 256 MB to 1GB RAM. Secure Digital (SD) cards are used to store the operating system and program memory. The boards have one to four USB ports. For video output, HDMI and composite video are supported, with a standard 3.5 mm tipping-sleeve jack for audio output. Lower-level output is provided by a number of GPIO pins.

5.3 Raspberry Pi 3: Raspberry Pi 3 has a 1.2 GHz 64-bit quad core processor, on-board Wi-Fi, Bluetooth and USB capabilities. It has a faster 1.4 GHz processor and has three times faster gigabit Ethernet or 2.4/5 GHz dual-band Wi-Fi. Other features include Power over Ethernet (PoE), network boot and USB boot. The Pi 3 can boot from USB, such as from a flash drive.

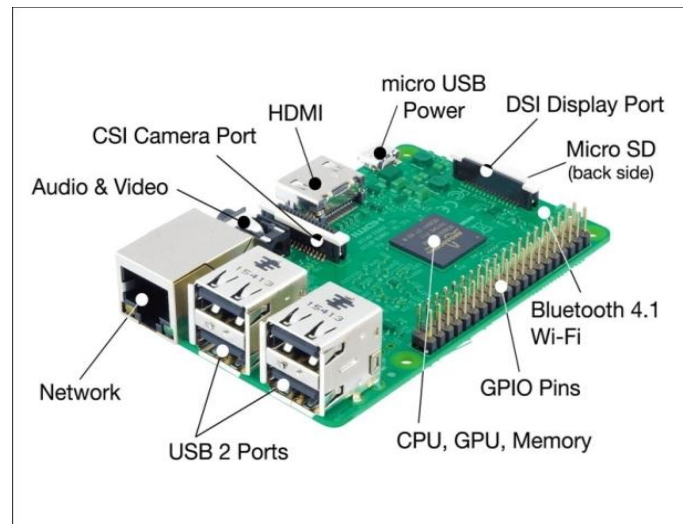

Fig-3: Raspberry Pi 3 kit

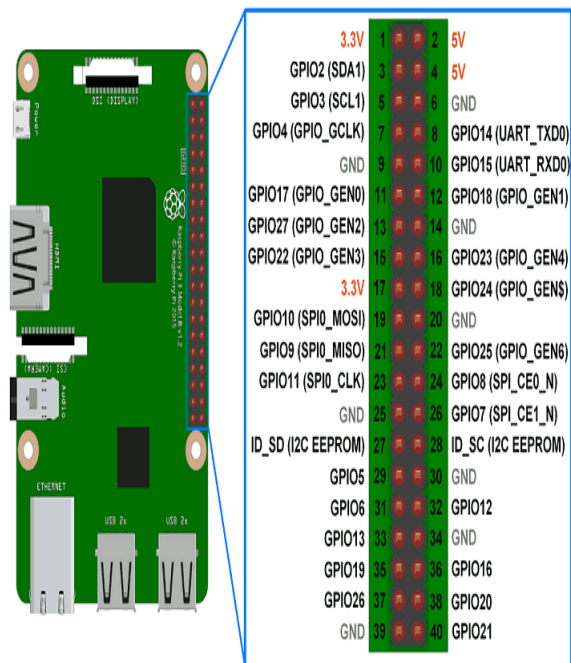

Fig-4: Raspberry Pi 3 Pin Diagram

5.4 Raspbian Software: Raspbian is a Debian based Linux distribution for operating system. There are several versions

of Raspbian such as Raspbian Stretch and Raspbian Jessie. Raspbian uses PIXEL, Pi Improved X-Window Environment, Lightweight as its main desktop environment. The distribution is shipped with a copy of computer algebra program Mathematical and a version of Minecraft called Minecraft Pi and a lightweight version of Chromium.

5.5 LCD Display: Liquid Crystal Display is a flat-panel display which uses the light-modulating properties of liquid crystals. LCDs can display images such as preset words, digits, and seven-segment displays. LCDs are used in a wide range of applications, including LCD televisions, computer monitors, instrument panels, aircraft cockpit display and signage.

5.6 7 inch LCD Display: The 7 inch standard display has 1024*600 hardware resolution. It supports back light, the backlight can be turned off for saving power. It supports Raspberry Pi, BB Black, Banana Pi and mini PC. It can be used as general purpose HDMI monitor. It can be used as a Raspberry Pi display which supports Raspbian, Ubuntu, Kali-Linux, Kodi, Win10 IoT, single touch, free drive. It works as a PC monitor and can support win7, win8, win10 system.

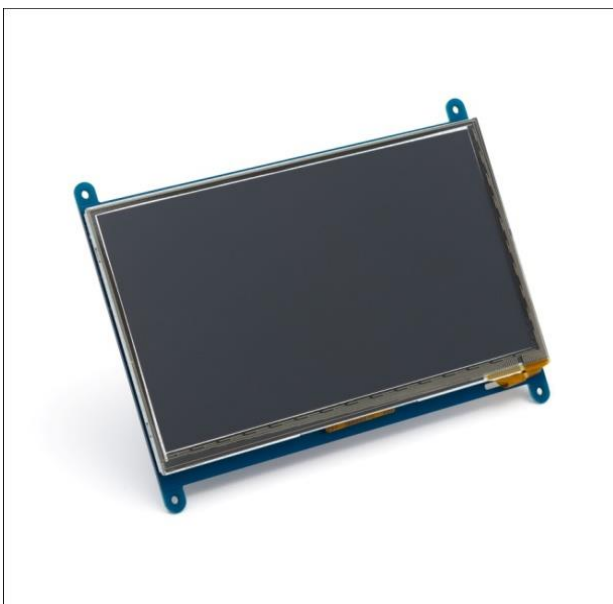

Fig-5: 7 inch LCD Display

5.7 Android Application: Android provides an application platform to build the applications and games for mobiles in Java Programming language. Android apps are built as a combination of distinct components that can be invoked individually. Apps can adapt to different devices. Android provides a flexible application platform provide for different device configurations.

5.8 Python: Python is a general-purpose, high-level programming language. Its design emphasizes code readability, and syntax allows programmers to express concepts in fewer lines of code. Python features both a dynamic type system and automatic memory management. Python supports multiple programming paradigm. It features a automatic memory management and has a standard library. Python interpreters are available for installation on many operating systems. Python was designed to be highly extensible.

5.9 My SQL: It is a relational database management system. It is free and open source software. It is written in C and C++ hence it is easy to use. It can also be run on cloud computing platforms. The data in My SQL is stored in tables and it is used for storing information. It supports data end users.

5.10 Android App Inventor: App Inventor for Android is an open-source web application originally provided by Google, and now maintained by the Massachusetts Institute of Technology (MIT). It is an intuitive, visual programming environment. It allows us to create software applications for the Android operating system (OS).



Fig-6: Android App

5.11 Google Firebase: Firebase provides a real-time database and backend as a service. The service provides application developers an API that allows application data to be synchronized across clients and stored on Firebase's cloud. The company provides client libraries that enable integration with Android, iOS, JavaScript, Java, Objective-C, Swift and Node.js applications.

6. IMPLEMENTATION

The main function of the system proposed is to construct wireless notice board to display messages sent from the user

through the network. It is a user friendly notice board that can be used to display the latest announcements with respect to date and time which can be easily tracked by the user. The user is the sender who gives the information to be displayed. The android app is installed in the mobiles of authorized users. The app is developed using the MIT App Inventor. The python programming language is used for dumping the program and for accessing the database My SQL is used. The app after creating successfully maintains an ID in Google Firebase wherein the data which are transferred are stored. For avoiding unauthorized access, security authentication such as user name and password are enabled. In the receiver side, the Raspberry Pi is connected to the LCD display which is given a 5V DC power from the power source. It connects data from the cloud. It receives data from the cloud by dumping the LINUX program. The interface between the LCD display and the Raspberry Pi is provided by a HDMI cable. The data that are displayed in the notice board are stored on Excel spreadsheet for future reference.

7. ADVANTAGES

This notice board can be accessed from anywhere. It includes better transmission of data in lesser time with good quality. The system is more secured as it involves user authentication. Here we can send text messages and also images in the form of Jpg, jpeg, png and pdf files with better quality. It is also provided with a deleting option. Hence this system becomes user-friendly.

8. CONCLUSION

The digitalized modern world paves many ways for creating exciting systems which are very much beneficial for the mankind. The wireless notice board which is developed as a user friendly notice board is a much needed one at institutions and in many areas for displaying their information from remote areas.

REFERENCES

- [1] Vinod B. Jadhav, Tejas S. Nagwanshi, Yogesh P. Patil, Deepak R. Patil. "Digital Notice Board Using Raspberry Pi" IJRET, Volume: 03, Issue: 05 | May-2016.
- [2] Bhumi Merai, Rohit Jain, Ruby Mishra. "Smart Notice Board". IJARCCCE, Issue: 05|April-2015.
- [3] J. S. Lee, Y. W. Su, and C. C. Shen, "A Comparative Study of Wireless Protocols: Bluetooth, Zigbee and WiFi", Proceedings

of the 33rd Annual Conference of the IEEE Industrial Electronics Society.

[4] Shruthi K., Harsha Chawla, Abhishek Bhaduri "SMART NOTICE BOARD", Department of Electronics and Communication, Manipal Institute of Technology, Manipal University, Karnataka.

[5] Rajeeb Lochan Dash, Mrs. A. Ruhan Bevi "Real-time Transmission of Voice over 802.11 Wireless Networks Using Raspberry Pi," IJEDR1401144 International Journal of Engineering Development and Research 793 IJEDR, Volume 2, Issue 1 ISSN: 2321-9939, 2014.

[6] About Raspberry Pi: www.raspberrypi.org: This is the official website of the Raspberry Pi project