

WIRELESS CHARGING OF BIONICS

V. Iswariya¹, V. Karthikeyan², A. Monisha Mirra³, Mrs. R. Birundha⁴

^{1,2,3}Final Year BE-ECE, SRM Valliammai Engineering College, Tamilnadu, India.

⁴Assistant Professor, Department of ECE, SRM Valliammai Engineering College, Tamilnadu, India.

Abstract: A Bionics is a device used as a replacement or enhancement of an organ as a mechanical version. These bionics are implanted in the human body by the surgical way. Every bionics have a lifetime. They must be replaced again and again after a certain period of time. This project is regarding the next step advancement of the bionics. In this project Bionics can be charged wirelessly by a method called Inductive coupling. By inductive coupling, the primary coil which is placed outside the body is energized by the AC current then it will generate an EM waves which in turn energize the secondary coil that is placed inside the body. Secondary coil generates the AC current. This AC current is converted into DC current by using bridge rectifier. Then the generated DC current is used to charge the battery. The Battery used in the Bionics will be considerably reduced resulting in the total reduced size of bionics. An external port shall be added in which the addition feature of Power bank facility can be added. This will be a Life savior feature by which we can charge the bionics in the emergency situations. The transmitter will be more mobile so, we can charge the bionics, whenever and wherever we want. The IR sensor and relay used in this system will help in the automatic cutoff of the power transmission. Therefore, only when receiver Module is brought near the Transmitter Module Power transmission will occur resulting in reduction in the power consumption.

Keywords - Bionics, Inductive coupling, Wireless Power Transmission.

1. INTRODUCTION

Bionic is a mechanical system that function like living organisms or parts of living organisms. Bionics can be highly advanced pieces of technology, able to integrated with various parts of the human body. This bionic can be implemented in human body by surgery. Charging of bionics is still a difficult process because every bionics have a certain life time. After certain period of time the battery should be replaced or charged again. For the replacement or charging of battery of the bionic, a surgery is needed. The aim of this project is to charge the rechargeable battery of the bionics wirelessly. So, we use wireless power transmission method to charge the bionics because WPT is predicted to be one of the fastest growing technologies and cost efficient. WPT is useful to power electrical devices

where interconnecting wires are inconvenient, hazardous or are not possible. In WPT, transmission of electrical energy is from a power source to an electrical load across an air gap without interconnecting wires. The WPT is effectively applied in electric vehicles, mobile phones. Among various WPT method, inductive coupling is used to charge the bionics. Inductive coupling is very efficient for smallest distance power transmission and it does not give any harmful effect to human body. We can change the power transmission of every bionic device depend upon the battery capacity. This can be done by changing the frequency and supply voltage. The efficiency of power transmission depends on distance between the transmitting and receiving coil.

2. LITERATURE REVIEW

There are few approaches proposed by researchers for wireless charging are

Reference [1] Wireless charging is a technology of transmitting power through an air gap to electrical devices for the purpose of energy replenishment. The recent progress in wireless charging techniques and development of commercial products have provided a promising alternative way to address the energy bottleneck of conventionally portable battery-powered devices. However, the incorporation of wireless charging into the existing wireless communication systems also brings along a series of challenging issues with regard to implementation, scheduling, and power management. In this paper, we present a comprehensive overview of wireless charging techniques, the developments in technical standards and their recent advances in network applications. In particular, with regard to network applications, we review the static charger scheduling strategies, mobile charger dispatch strategies and wireless charger deployment strategies.

Reference [2] Wireless power transmission (WPT) has been attracting a wide range of subjects in various fields and also become a highly active research area because of their potential in providing high technology to our daily lives. The wireless power transmission will be mandatory to use in the near future because this technology enables the transmission of electrical energy from a power source to an electrical load across an air gap without interconnecting wires. In this paper, we carry out a pilot study to present

the existing technologies of wireless power transmission, their recent technology as well as its future trends.

Reference [3] In this paper, the development wireless power charging system for mobile device based on magnetic resonance coupling is proposed. The system is comprised of three parts; a transmitter circuit to generate the AC signal to be transferred, transmitting and receiving radiators to transfer the power of AC signal wirelessly, and a receiver circuit to convert the received AC signal into DC voltage for charging the mobile device. The system is designed to work at frequency of 10MHz empowered by an Op-Amp AD8067ART at the transmitter to produce the AC signal. The radiators for transmitting and receiving 10MHz AC signal are implemented using micro strip line which is separated each other by narrow space to obtain the optimum coupling. Whilst the receiver is constructed of a simple voltage double circuit which also works as a rectifier. From the experimental characterization, it is demonstrated that the wireless power charging system with 0.8mm distance of radiators is able to produce DC at the output of receiver circuit chargeable a battery of mobile phone in which this voltage is equivalent to AC signal at the transmitter circuit.

Reference [4] Wireless charging system with rapid charging algorithm based on a simplified electro-chemical battery model is proposed. The operational principle of the proposed scheme is verified with a 200W WPT prototype. Model based charging algorithm development for adaptive charging of battery to not only fast charge the battery but mitigate the associated deleterious thermal and degradation effect. It is shown that battery can be wirelessly charged at ultra fast speed of 4 minutes for 100% charging.

3. EXISTING SYSTEM

Bionic organs have a limited lifetime where its battery needs to be replaced in order for it to function continually. The limited battery battery causes the patient to be subjected to an operation every time the battery life comes to its end. This put the patient in great danger and discomfort. In this method for the replacement of battery, anesthesia is given to the patients and then surgery is done to replace the battery of the bionic.

4. PROPOSED SYSTEM

The purpose of our project is to charge the bionic without surgery is used to charge the battery. WPT is categorized into two methods that is near field and far-field transmission. In general, near-field power transfer methods have higher efficiency in comparison to the far-field ones. Most of the WPT applications are using the near-field method. In order to consider any region to be near-field, two conditions should be considered: first, the distance

between the transmitter and receiver coil should be less than one wavelength at the operating frequency and secondly, the largest dimension of the transmitter coil should be less half of the wavelength. In this paper, the focus is on the applications of near-field power transfer methods.

Bionic near-field WPT methods use operating frequencies within the range of 100 kHz to 50 MHz Comparing the wavelength at this range with the typical transmission, which is between 1 cm and 11 cm, the corresponding of the electromagnetic field is relatively long. Therefore, the transfer can be viewed as a near-field process. There are three major ways to accomplish a near-field WPT:

- Capacitive coupling based on electric fields.
- Inductive coupling based on magnetic fields.
- Magnetic resonant inductive coupling. WPT by inductive coupling is the main alternative to bionic devices.

5. BLOCK DIAGRAM

5.1 RECEIVER MODULE



Fig 1: Block Diagram of Receiver

5.2 TRANSMITTER MODULE

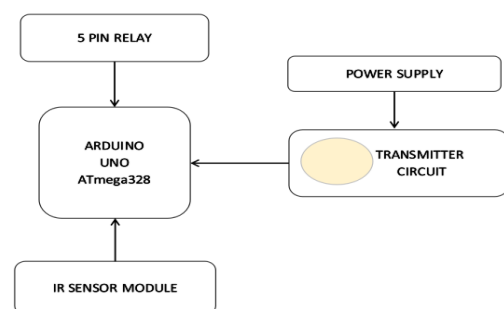

Fig 2: Block Diagram of Transmitter

6. HARDWARE REQUIREMENTS

6.1 ARDUINO ATMEGA328

The Arduino Uno is a microcontroller board based on the ATmega328. It has 20 digital input/output pins of which 6 can be used as PWM outputs and 6 can be used as analog

inputs. Arduino consists of both a physical programmable circuit board and a piece of software. Software or IDE (Integrated Development Environment) that runs on your computer, used to write and upload computer code to the physical board.

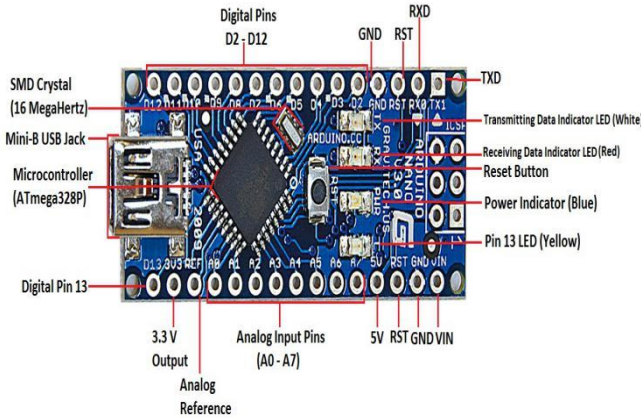

Fig 3: Arduino Board

6.2 5V RELAY

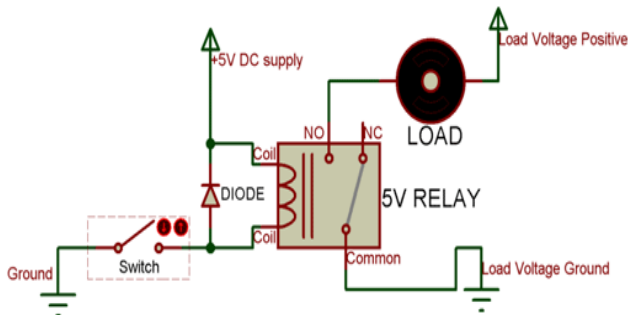

Fig 4: Internal circuit of Relay

The relay is the device that open or closes the contacts to cause the operation of the other electric control. It detects the intolerable or undesirable condition with an assigned area gives the commands to the circuit breaker to disconnect the affected area. Thus, protects the system from damage.

6.3 VOLTAGE REGULATOR

Voltage regulators are very common in electronic circuits. They provide a constant output voltage for a varied input voltage. 7805 signifies two meaning “78” means that it

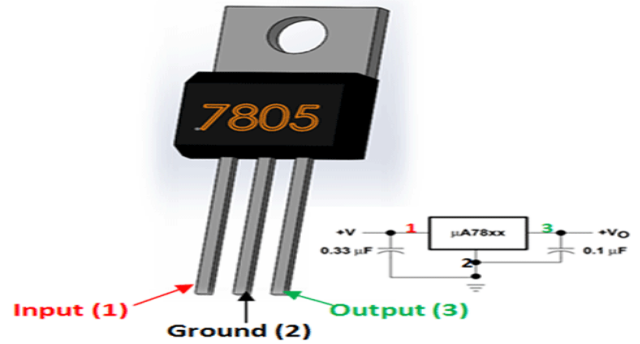

Fig 5: voltage regulator pin and circuit diagram

is a positive voltage regulator and “05” means that it provides 5V as output. So, 7805 will provide a +5V output voltage. The output current of this IC can go up to 1.5A. But the IC suffers from heavy heat loss hence a Heat sink is recommended for projects.

7. SOFTWARE REQUIREMENTS:

For implementing this project, we are using the Arduino UNO as the microcontroller for interfacing the hardware and software. The software used is ARDUINO 1.8.8 (IDE). It is an open source software making it easy to write code and upload it to the Arduino board. It runs on WINDOWS, MAC OS X and LINUX. The environment is written in JAVA and based on processing and another open source software.

8. FLOW CHART

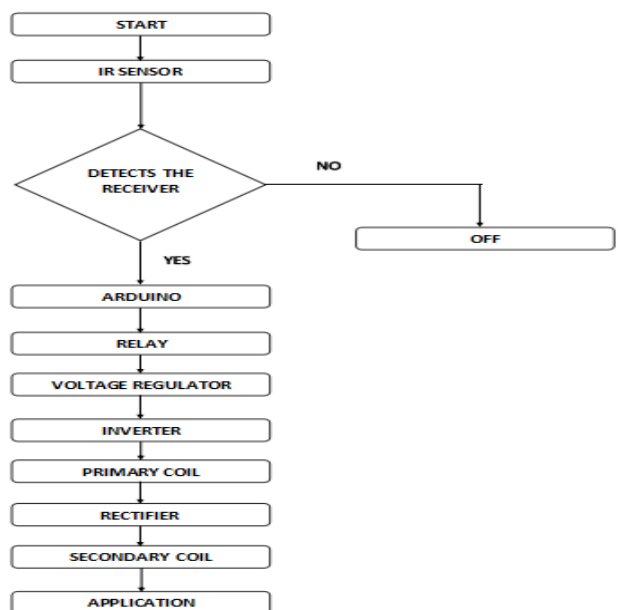

Fig 6: flowchart of total methodology of wireless powerless transmission

9. RESULT

The Bionics are expected to charge wirelessly. Now the size of the battery is reduced which in turn results in the reduction of the total size of the Bionics. An External port is added for the connectivity of the power bank facility. The power will auto cutoff when the bionics are misplaced resulting in the reduction of the power consumption.

INPJUT VOLTAGE (V)	DISTANCE (cm)	OUTPUT VOLTAGE (V)	EFFICIENCY (%)
6	4	0.3	5
6	3	2.4	40
6	2	2.8	46

Fig 7: Table of the input and output recorded values

10. CONCLUSION:

Thus, the Bionics such as arm or leg replacement, hearing aid and heart pacemakers can be charged wirelessly. So, the surgical process for the replacement of the battery can be ignored. The battery of the bionics is reduced which results in the reduction of the total size of the bionics. The Relay circuit and IR sensor present in the transmitter circuit shall help in the reduction in the power consumption. The power bank facility shall be a life savior in the emergency situations. Therefore, increasing the mobility of the wireless charger

REFERENCES

[1] Xiao Lu, Ping Wang, Dusit Niyato, Dong In Kim, Zhu Han, "Wireless Charging Technologies: Fundamentals, Standards, and Network Applications", *IEEE Communications Surveys & Tutorials*, vol 18, No.2, Second quarter 2016.

[2] Mohammad Shidujaman, Hooman Samani, Mohammad Arif, "Wireless Power Transmission Trends", 3rd international conference on informatics, vision 2014.

[3] Achmad Munir* and Biru Tuter Ranum "Wireless Power Charging System for Mobile Device Based on Magnetic Resonance Coupling", 5th international conference on Electrical Engineering and informatics, August 2015.

[4] Bong-Chul Kiml, Ki-Young Kiml, Sanoop Ramachandra2, and Ashish Khandelwall, "High Efficiency Wireless Charging

System with Rapid-Charging Strategy", 978-1-4673-1/16, 2016.

[5] Tianjia Sun; Xiang Xie; Guolin Li; Yingke Gu; Yangdong Deng, Zhihua Wang, "A Two-Hop Wireless Power Transfer System With an Efficiency-Enhanced Power Receiver for Motion-Free Capsule Endoscopy Inspection, "Biomedical Engineering, IEEE Transactions on, vol.59, no.11, pp.3247,3254, Nov. 2012.

[6] R. Bosshard and J. W. Kolar, "Inductive power transfer for electric vehicle charging: Technical challenges and tradeoffs," *IEEE Power Electronics Magazine*, vol. 3, no. 3, pp. 22-30, 2016.

[7] SAE Standard J2954, "Wireless Power Transfer for Light-Duty Plug-In/Electric Vehicles and Alignment Methodology," Nov 2017.