

# INTERLEAVED DC-DC BOOST CONVERTER WITH HIGH VOLTAGE GAIN AND EFFICIENCY FOR SOLAR ENERGY SYSTEMS

M. Pradeep Kumar<sup>1</sup>, K. Prasanth<sup>2</sup>, M. Praveen<sup>3</sup>, R. Sheik Packeer<sup>4</sup>, R. Arivalahan<sup>5</sup>

<sup>1,2,3,4</sup>UG Students, Department of Electrical and Electronics Engineering  
Valliammai Engineering College, Kattankulathur, Kancheepuram, Tamil Nadu-603203, India

<sup>5</sup>Associate Professor, Department of Electrical and Electronics Engineering  
Valliammai Engineering College, Kattankulathur, Kancheepuram, Tamil Nadu-603203, India

\*\*\*

**Abstract:** An Interleaved converter with coupled inductor and multiplier circuits are presented in this paper. Interleaving is done to minimize the size of the filter components. In this converter, better gain with improved efficiency is obtained without the high duty cycle of the switches used. The Converter is able to boost the Voltage to a Desired Level without Transformer. Further with this interleaved design the peak to peak current variation and losses which are due to switch operation is minimized. The interleaved boost converter has been designed with 12 V as input and 100V as the output. The primary windings of the inductor are used for minimizing the ripple current, while the secondary windings are set in series to maximize the voltage gain.

**Keywords:** Interleaved converters, solar energy conversion, dc-dc boost, high power output, high efficiency.

## 1. INTRODUCTION

Power Generation by Non-renewable resources result in Pollution around the world. The Depletion of these resources prove to be a Major Concern for Future Generation. Thus the Need for Alternative Power Sources are Essential. Out of the available Renewable sources, solar Power Generation has a better Potential and Most Reliable among the others and they are also the Fast Developing Alternative Power Source in the Present Time. MPPT Controller helps in Improving and Utilizing the available Source in the Maximum Possible way. The conventional Boost Converters for High Voltage Step Gain have Higher Ripple Current and Voltage which are responsible for Losses. Further they are affected by the pulsating input current due to the switched operation of capacitors or inductors. For minimizing these Losses and also to improve the Overall Efficiency, the Interleaved Operation is suggested. This Converter setup makes use of the Multiplier circuits to improve the Output Voltage. The Coupled Transformer will reduce the Cost. The Leakage Inductance will be fed back to the Transformer. The Converter and the Coupled Inductors are present along with the Voltage Multiplier circuit are used for the operation. The Converter decreases the Inrush Current in the Inductor which improves the Performance and thereby reducing the Stress.

## II. METHODOLOGY

The Boost Converter is one of the common methods of Stepping up the Voltage. The Conventional Boost Circuit uses a simple Configuration and has a respectable Voltage step up. But the Voltage Stress and very High values of Ripple Current and Voltage are undesired since these are factors in Reducing the Efficiency.

The Commonly used Boost Converter circuit is in Fig.1

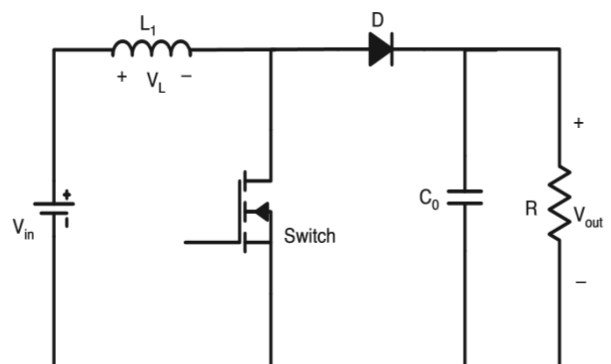

Fig.1

The Interleaved converter utilizes the interleaving Principle for operation. The Proposed Interleaved Converter has a Modified Output Capacitor Connection. 180° out of Phase operation of the mosfet switches results in Currents also of the same condition. This Method reduces the Switching Losses as the Current as the input is split on Several Phases. To avoid Inrush, Diodes and Inductors are connected in Series. Losses due to the functioning of switching and diodes are minimized with ZVS and ZCS operations.

An Interleaved Boost converter with High Step Gain using Two Coupled Inductor and High Capacitor Filters are Shown in Fig 2.

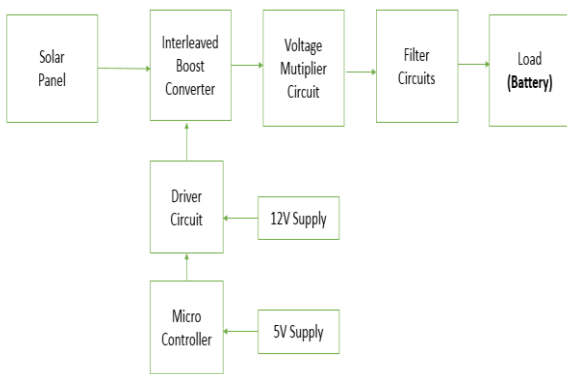

Fig.2

### III. CONSTRUCTION

#### A. INTERLEAVED CONVERTER:

The interleaved converter is as on the following figure with two sets of diodes, capacitors, inductors for interleaved operation or the alternate operation of phases. The converter will boost the voltage at the initial stage. This configuration is done so that the converter will not struggle at higher duty cycles. It has been proved that interleaving operation is much better in terms of efficiency and performance than conventional converter. This setup has the potential to utilize the power obtained from the sun in an more efficient manner.

The Interleaved Boost Converter is as in the fig.3

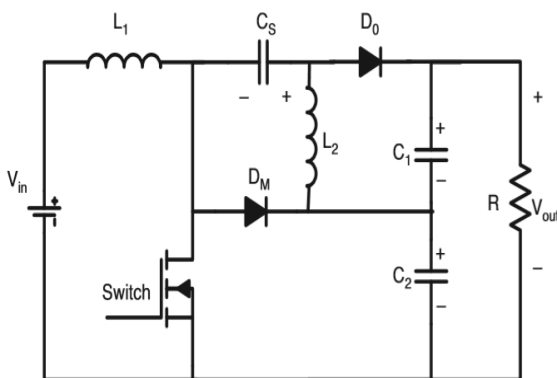

Fig.3

#### B. MPPT with fuzzy logic :

Maximum Power Point Tracking with Fuzzy logic is used to utilize the maximum available power from the solar cell for operation. where as fuzzy logic coupled with MPPT gives a many valued logic for the which has values of 0 and 1 and are not fixed to a only one of the them as a default instead they are fixed according to the operation. The mppt with fuzzy logic is implemented on the pic

microcontroller. The fuzzy logic control in a MPPT is as shown in fig.4

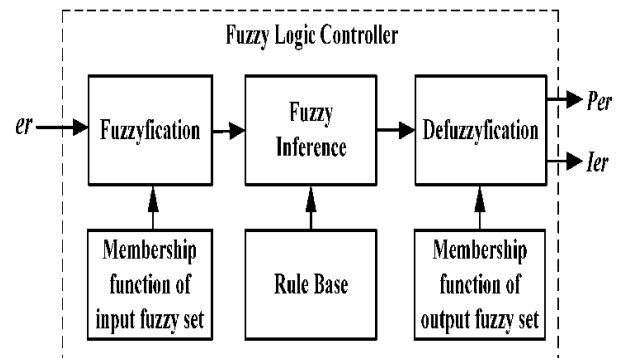

Fig.4

A representation of a type of Pic16f877 microcontroller interfaced with the mppt using fuzzy logic is mentioned in the fig.5.



Fig.5

#### C. TWO STAGE VOLTAGE MULTIPLIER CIRCUIT:

A voltage multiplier is used to step up a voltage which is given to the circuit. The voltage multiplication is done by making use of the two stages of the circuit. Most simple multiplier circuit consists of connections of capacitors and diodes which vary according to the requirements of the boosting of the voltage given as input. The stepping up can also use the single pole double throw switches. In other words the multiplier circuit used is to step up the voltage to a higher value.

The Two stage voltage multiplier circuit is as shown in fig.6

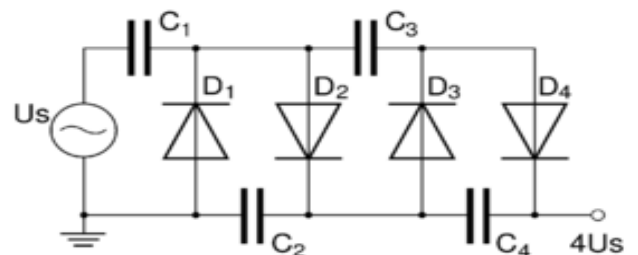

Fig.6

**D. HIGH VOLTAGE CAPACITOR FILTERS:**

High Voltage Capacitor DC filter are necessary to produce the required smooth voltage waveform from Non uniform voltage sources. Large values of currents and ripples are removed by energy storing in the capacitors and expelling charges in a defined manner. High voltage capacitor filters makes use of capacitance reactance. A simple high pass filter circuit using inductors and capacitors are as in fig.7

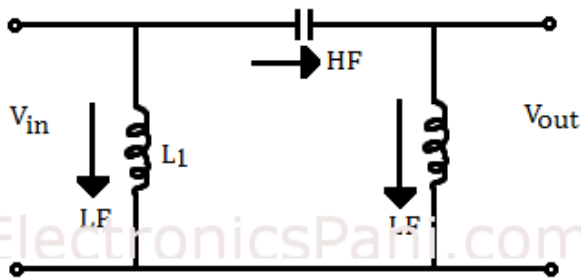

Fig.7

**E. DRIVER CIRCUIT:**

The driver circuit is used for turning on and off of the MOSFET semiconductor switches for the operation of the interleaved converter. The driver circuit is fed by a DC supply.

**IV. OPERATION**

The turning on and off of the MOSFET semiconductor switches is carried out by a driver circuit which is in turn interfaced with the microcontroller. The microcontroller and the driver circuit is supplied with separate dc supply for operation. In the On state, the Diodes are Reverse Biased and the charges are Stored in Inductors. The Voltage Flows from L1 to L2 through Cs and C2. The Capacitor Voltage obtained is similar to the Voltage from the Switches.

Fig.8. ON condition of the Interleaved Boost Converter.

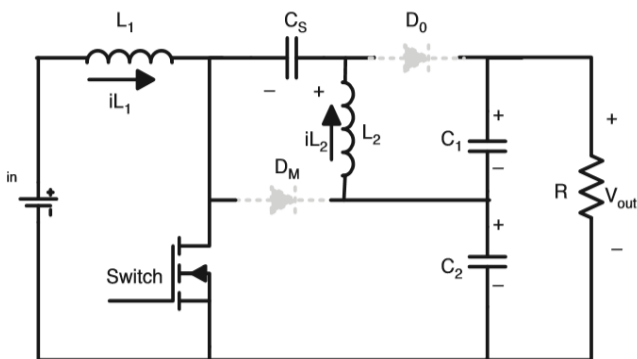

Fig.8

In the OFF state, the Diodes are in Forward Biased and the Charges present in L1 begins Discharging. The Output flows from Capacitors from Cs and C2, then Inductor L2 Discharges through Diode D0. The Voltage from the switch is identical to the Capacitor Voltage.

Fig.9. OFF state of Interleaved Boost Converter.

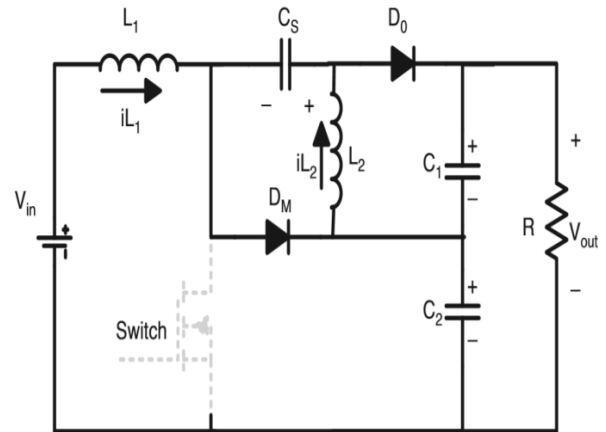

Fig.9

**A.WORKING:**

The solar panel provides the necessary input voltage for the converter to operate. The pic microcontroller is interfaced with mppt using fuzzy logic. The controller circuit will help the driver circuit for turning on and off of the mosfet switches in the interleaved boost converter. this helps the working of the converter as mentioned in the operation of the converter. The two stage voltage multiplier circuit will further help in the boosting of the output voltage. The filter circuits help in removing the harmonics and in reducing the ripple voltage and current values. The load side consists of a battery as in this case which will be charged by the help of the step upped voltage from the solar panel. The circuit is made not only to boost the voltage but also it will be used faster charging of the battery than conventional boost converters for better utilization of the available power.

**V. DESIGN CONSIDERATIONS**

- Input Voltage = 12 Volts
- Output Voltage = 100 Volts
- Output current = 3 Amps
- Output power = 300 watts
- Switching frequency = 2 MHz
- Inductance = 24 μH

Capacitance = 33  $\mu$ F

Resistance = 250  $\Omega$

The Equivalent Circuit Diagram of the presented Converter is represented in the Fig.10.

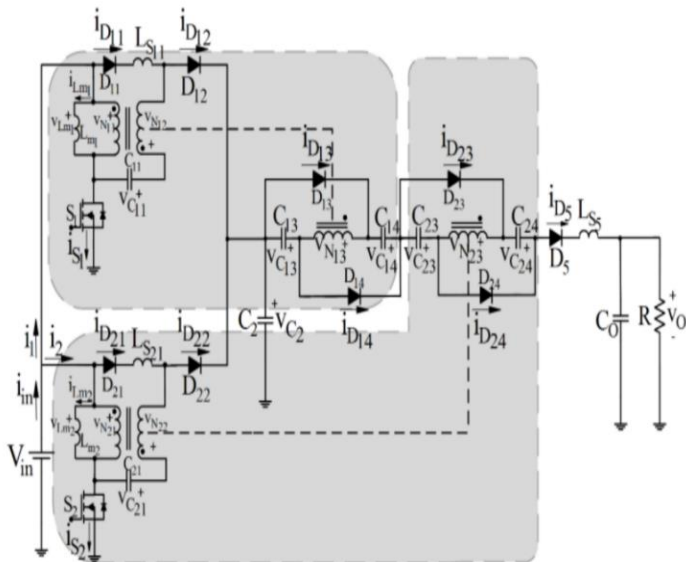

Fig.10 Equivalent Circuit

The Expected Output results from the Simulink model using MATLAB is as represented in the following figures.

**OUTPUT VOLTAGE:**

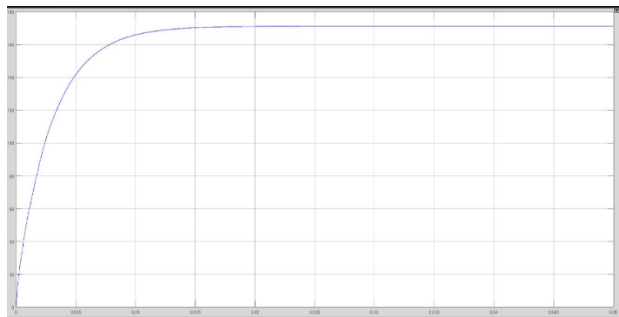

Fig.11

**SWITCH OUTPUT:**

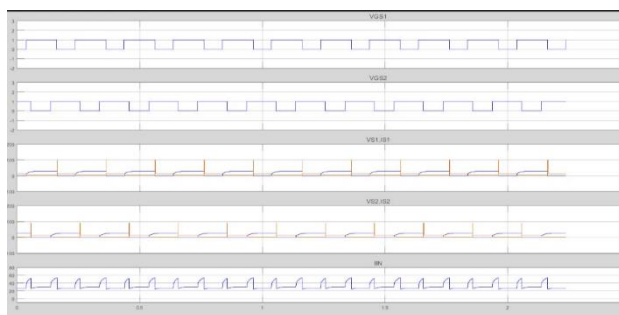

Fig.12

**DIODE CURRENTS:**

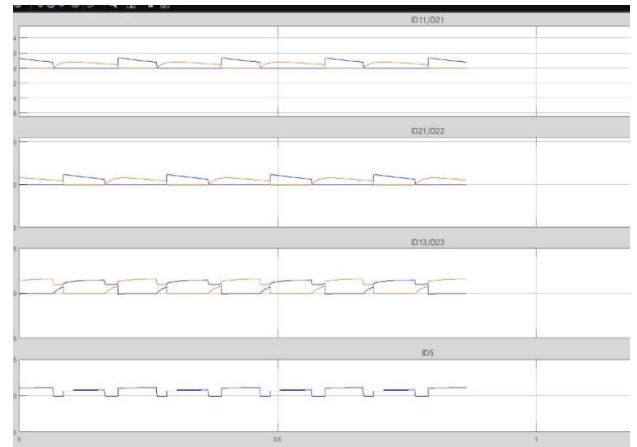

Fig.13

**VI. DISCUSSION**

The interleaved boost converter is used here to show that the maximum utilization of available solar energy could be done in a better way than conventional converters available. The converter is realized in a way that the stepped up voltage also has an adequate current rating which is very much essential in faster charging of the battery. With further research and development these converters could very well be used for stepping the voltage for high voltage dc transmission.

**VII. CONCLUSION**

The design of interleaved converter from conventional converter is done. The existing conventional converter even though having a similar output voltage has higher ripple values and also at higher duty cycle the converter struggles, and also their efficiency gets reduced due to higher stress for a longer time of operation. While the interleaved boost converter has a higher efficiency with lower losses and ripples values and the converter does not struggle like the conventional step up boost converters. Hence they are very much reliable than the conventional boost converters used for harvesting the solar power.

**VIII. ACKNOWLEDGMENT**

The successful completion of the project requires a lot of guidance and assistance from many people and we are extremely happy to get this all along till the completion of the project. Everything we have done for the project only because of such guidance and supervision of the people and we would never forget to thank them. We would like to express our gratitude to the Valliammai Engineering College, for the encouragement and support of our project.

We would like to thank our guide and review panelists for their guidance and support which made this work come true. Finally, we would like to thank our family and friends for supporting to do the work.

#### IX. REFERENCES

1. B. Axelrod, Y. Berkovich, and A. Ioinovici, "Switched capacitor/switched-inductor structures for getting transformer less hybrid DC-DC PWM converters," *IEEE Transactions on Circuits and Systems I: Regular Papers*, vol. 55, pp. 687-696, 2008.
2. Y. P. Siwakoti, F. Blaabjerg, and P. C. Loh, "High Step-Up Trans-Inverse (Tx- 1) DC-DC Converter for the Distributed Generation System," *IEEE Transactions on Industrial Electronics*, vol. 63, pp. 4278-4291, 2016.
3. Shahin, A. Hinaje, M. Martin, J. P. Pierfederici, S. Rael, S. Davat, B., "High voltage ratio DC-DC converter for fuel-cell applications", *IEEE Trans. Ind. Electron*, 57(12): 3944-3955 (2010).
4. X. Zhu, B. Zhang, Z. Li, H. Li, and L. Ran, "Extended Switched-Boost DC-DC Converters Adopting Switched-Capacitor/Switched-Inductor Cells for High Step-up Conversion," *IEEE Journal of Emerging and Selected Topics in Power Electronics*, vol. 5, pp. 1020-1030, 2017.
5. Pan, C. T. Lai, C. M., "A high efficiency high step-up converter with low switch voltage stress for fuel-cell System Applications, *IEEE Trans. Ind. Electron*, 57(6): 1998-2006 (2010).
6. M.Schuck and R. C. Pilawa-Podgurski, "Ripple minimization through harmonic elimination in asymmetric interleaved multiphase DC-DC converters," *IEEE Transactions on Power Electronics*, vol. 30, pp. 7202-7214, 2015.
7. Nicola, F., Giovanni, P.: 'Optimization of perturb and observe maximum power point tracking method', *IEEE Trans. Power Electron.*, 2005, 20,(4), pp. 963-973.
8. Gules, R., Pfitscher, L.L., Franco, L.C.: 'An interleaved boost DC-DC converter with large conversion ratio'. *IEEE Int. Symp. Industrial Electronics*, 2003, pp. 1-5