

# Design and Fabrication of Multi Legged Robot

S.N. Teli<sup>1</sup>, Rohan Agarwal<sup>2</sup>, Devang Bagul<sup>3</sup>, Pushkar Badawane<sup>4</sup>, Riddhesh Bandre<sup>5</sup>

<sup>1</sup>Professor, Mechanical Engineering Department, BVCOE, Navi Mumbai

<sup>2,3,4,5</sup>Final Year Student, Mechanical Engineering Department, BVCOE, Navi Mumbai

\*\*\*

**Abstract** – On the surface of the earth, there is the presence of wheeled and tracked vehicles. People, as well as animals, can go anywhere by the help of legs. Machine mainly consists of various mechanisms for their successful operation to get the desired output. Some of the famous mechanisms are the four-bar mechanism, single slider crank mechanism, double slider crank mechanism, etc., used for transmitting motion, force, torque etc. Our aim is to design and fabricate mechanical multi-legged robot and deformation in the kinematics links by using CADD software. The analytical data can be further used for reference purpose to design a walking robot to attain better design qualities. The analysis of the robot is based on the FEM concept integrated into Cad software called ANSYS R16.2. The aim of this project is to create an eight-legged robot to test new walking algorithm. We loosely based our design on spider because there has an advanced way in robotics on octopedal locomotion. Hopefully, the algorithm developed will be of use for the robotics community and in future society.

The Fig.1 illustrates the main two mechanisms i.e. Jansen Mechanism and Klann Mechanism

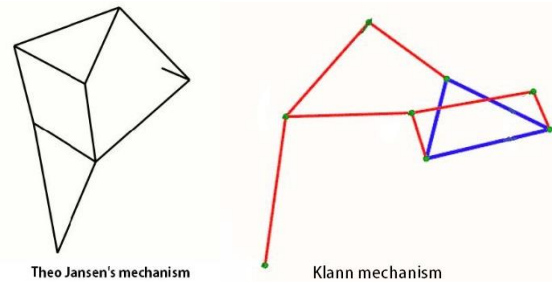

Fig 1. Jansen & Klann Mechanism

**Key Words:** Klann, Jansen, Simulation, Coupled, Transient, Torque, Dynamic

## 1. INTRODUCTION

Klann linkage is developed by Joe Klann in 1994. This mechanism is a planar mechanism that converts the rotary motion of the crank to linear movement of the foot of the robot for one-half rotation of the crank & raises the foot for the second half and thus returning it to the starting point. Two of these linkages are at 180 degrees out of phase, will function as a wheel replacement. It was fabricated to simulate the gait of legged animal, example spider. Here the wheels are mostly replaced by either four legs or six legs sometimes eight legs is also possible to design a terrain robot. The linkage consists of following parts: - frame, a crank, two grounded rockers, and two couplers all connected by pivot joints. It consists of 6 links per leg. Another popular mechanism is Theo Jansen's mechanism, designed by Theo Jansen to simulate a smooth walking motion. Theo Jansen has used his mechanism in different kinds of kinetic sculptures which are known as Strandbeests. There are many types of leg mechanisms such as Eight-bar leg mechanism, Strandbeests (applied Jansen linkage), Tokyo Institute of Technology walking chair, Ghassaei Linkage Tchebyshevs plant grade machine. But out of them, Klann mechanism and Jansen mechanism are most popular and are considered best in design.

The above image shows how the links connected to other links and how they can simulate. Klann mechanism is somewhat better in design because of their smaller number of links as compared to Jansen's linkage. Therefore, we choose computer-aided design and analysis of walking robot based on Klann mechanism by using some CAD tools. These robots can basically go anywhere like living organisms on terrain areas and rocky areas as well as muddy surfaces.

There are many types of walking mechanisms but the 2 mostly method used are Theo Jansen's Mechanism and Klann mechanism. So, we have decided to perform analysis by the help of Klann mechanism. Klann mechanism or linkage is basically an expansion of the four-bar mechanism. It was developed by Joe Klann in the Year 1994. wheels are basically ineffective on rough & rocky areas, thus robot with legs provided with Klann linkage are advantageous for walking vehicles.

The proportion of individual link in the mechanism is to optimize the linearity of the foot for one-half of the rotation of the crank. The remaining rotation of crank helps the foot to be raised to a predetermined height before returning to the starting position. Two of these linkages are coupled together at the crank and one-half cycle out of phase with each other will allow the frame of a vehicle to travel parallel to the ground. Our project is mainly useful for hazardous material handling, clearing minefields, or secures an area without putting anyone at risk. Wheels are mainly ineffective on rough and rocky areas, therefore robot with legs provided with Klann mechanism is beneficial for advanced walking vehicles. It steps over curbs, climbs stairs or travel areas that are currently not accessible with wheels. In this mechanism, links are mainly connected by the help of pivot joints and

convert the rotating motion of the crank into the movement of foot similar to that of animal walking. The proportions of each link in the mechanism are designed to optimize the linearity of the foot for one-half of the rotation of the crank. The remaining rotation of crank allows the foot to be raised to a predetermined height before returning to the starting position and repeating the cycle. The military, law enforcement and private security firms can also be benefitted from applications of a mechanical spider. That below images shows some of the walking robots which are developed for rough terrain areas.

The Fig. 2 illustrates the Actual Four Leg mechanism known as Cheetah.

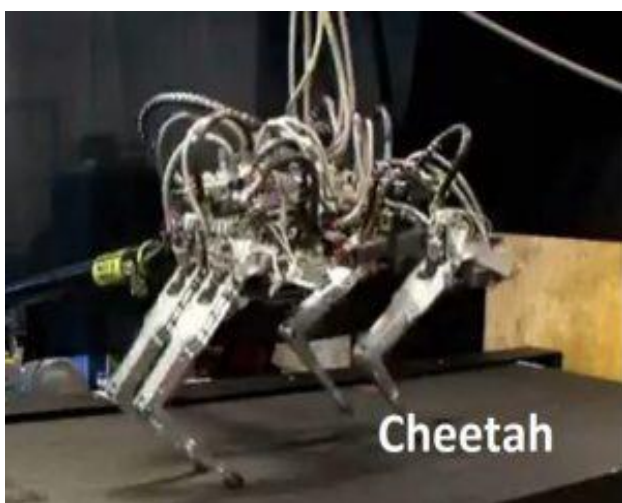

Fig 2. Cheetah Mechanism

The Fig. 3 illustrates the Four Leg mechanism known as Little Dog.



Fig 3. Little Dog Mechanism

Advantages of Walking Robots over Wheeled Robots:

1. Legged robots & vehicles can navigate to any kind of surfaces which is not possible for robots with wheels.
2. Wheel robots cannot jump or step and hence they have to take a different path, whereas legged robot can jump and step over obstacles.
3. Wheels require a continuous path to travel whereas legs can travel on any surface.
4. Legged robot helps us in exploring human and animal locomotion whereas it is impossible for wheel legged robots.
5. Once we start travelling from our regular habitat to the rough, rocky, sandy, steep and undesired terrain, we can understand that our brilliant invention of wheels turns out absolutely useless.

## 2. KLANN MECHANISM

It is basically a planar mechanism designed to simulate the gait of legged animal & function as a wheel replacement. The linkage consists of the following parts such as frame, a crank, two grounded rockers, and two couplers all connected by pivot joints. The proportions of links in this mechanism are defined to optimize the linearity of the foot for one-half of the rotation of the crank.

The left-over rotation of crank allows the foot to be raised to a predetermined height before returning to the starting position and repeating the cycle. Two of these linkages are coupled together at crank and one-half cycle out of phase with each other will allow the frame of a vehicle to travel parallel to the ground.

Joseph Klann has examined that all the combinations of dimensions calculated by this method may not work. There are many sets of dimensions that do not gives a smooth gait. So, we will make a small prototype to see its working of the following Length from Acrylic or Hard Cardboard to test our decided dimensions.

- Length of upper Rocker arm = 36.4 mm
- Length of lower Rocker arm = 26 mm
- Length of Connecting arm = 102 mm
- Length of Leg = 151 mm
- Angle of Connecting arm = 170°
- Angle of Leg = 142°

The Fig. 4 represents a demo diagram of Single leg mechanism.

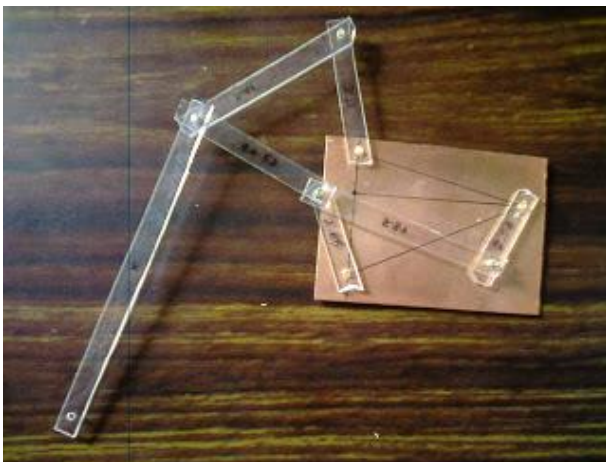

Fig 4: Rough Sketch of Leg

### 3. DETERMINATION OF DIMENSIONS OF FRAMES AND BASE PLATE

The whole setup is set upon the base plate. Also, holes have been drilled on the frame, any misalignment in the assembly, will result in complete failure. Thus, frame & base plate are designed in way that the movement of linkages is not disrupted. After, carefully studying and considering all the constraints we decided this set of dimensions:

- Length of base plate = 280 mm
- Width of base plate = 170 mm
- Length of frame = 230 mm
- Width of frame = 230mm
- Length of the shaft = 90mm
- Diameter of the shaft = 3mm
- Number of shafts = 4
- Thickness of the plate = 1mm

The Fig. 5 represents the actual model made by us i.e. the Multi legged Robot.

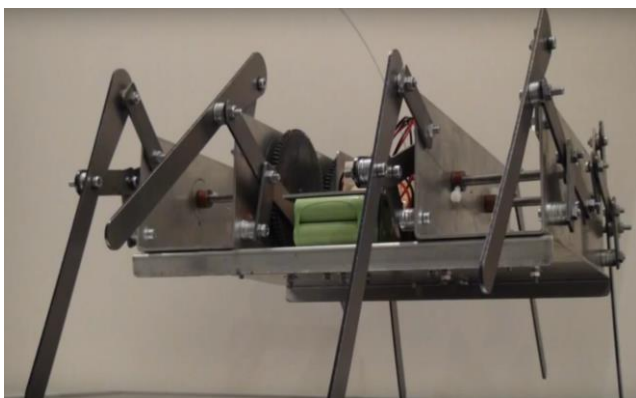

Fig 5: Construction

The Fig. 6 represents the actual model parts and parts name have been indicated.

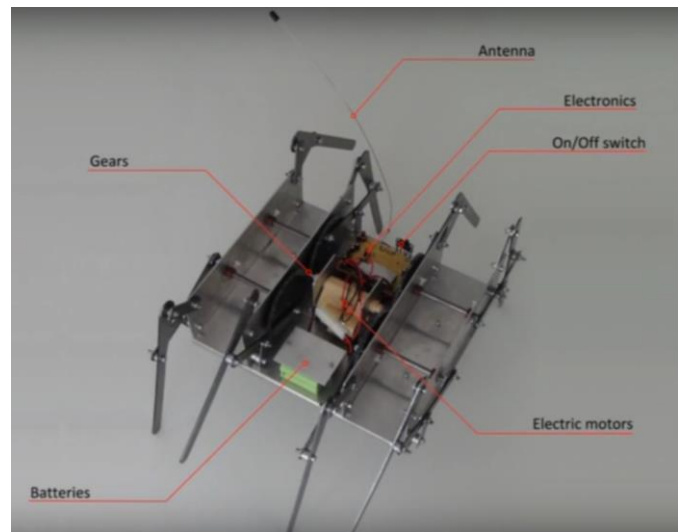

Fig 6: Parts of Model

### 4. CONSTRUCTION

It basically consists of motor mounted at the top. Out of the three-spur gear, mounted on the frame, one is connected to motor Driving gear and remaining two are meshed with driving gear. As the motor is switched 'ON' the driving gear starts rotating, another two gears, one in the clockwise while other is anticlockwise rotates. This rotation results in the crank rotation. Crank movement force the link which gives the momentum in a particular line of action with help of supporting link. The input to the supporting link is to move the arm in a particular profile which made by the end point of arm and move back to its normal position. This gives the walking motion to the arms of the robot.

The Fig. 7 represents the Multi legged robot in the workshop.



Fig 7: Actual Model Manufactured



### 5. DIMENSION AND PATH TRACKING ON LEGS

The project is mainly based on the default dimension for the Klann linkage from the Klann website to do analysis as well as CAD modelling for walking robot. But now we are going to check out the changes in the dimensions of the legs & thus observe the change in the path traced by the point where the main leg link touched with the ground. NOTE: no changes have been done in the dimensions of the links present.

The Fig. 8 represents the path traced by the point on the main leg of Klann mechanism, and how the legs are moving forward and backward.

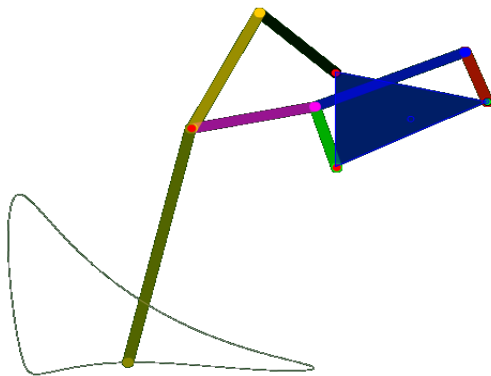

Fig 8: No dimension changed

The Fig 9, shows how the path traced by the point on the main leg link. When it is touching the ground, the path is little twisted so that the flexibility and stability of the leg are changed and it is not suitable for the design of a walking robot.

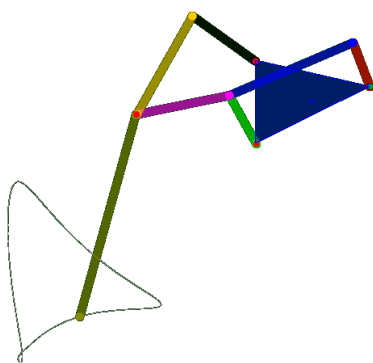

Fig 9: Dimensions changed in the Connecting arm

The Fig. 10 shows the path traced by the point on the main leg link. It is somewhat similar to the Fig 8, but here the project cannot observe the motion of the main leg link. If we see the motion of the main leg link, there is a difference in the motion velocity.

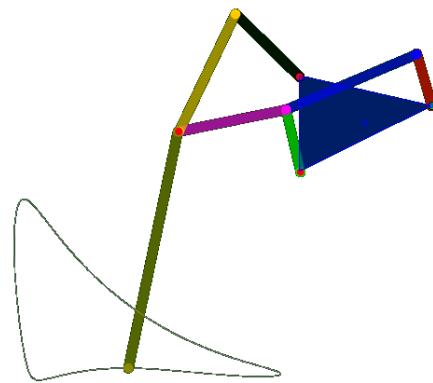

Fig 10: Change in crank dimensions

### 6. INTRODUCTION TO ANSYS

**Ansys Inc.** is a famous engineering simulation software. This company is American public company based in Canonsburg, Pennsylvania. This software is mainly used for designing different products & semiconductors, as well as to create simulations that are used to test a product's durability, temperature distribution, fluid movements, and electromagnetic properties. Ansys was founded in 1970 by John Swanson. ANSYS software provides different platforms to analysis different types.

Before we proceed towards the analysis part, we are going to consider only one leg fixed to the frame, this will automatically reduce the difficulty of the analysis and thus reduce the number of the elements.

For the process of the analysis, we are going to consider a DC Motor which is fixed of 100 rpm with a torque of 16 kg-cm. the above input is only considered for dynamic analysis. By the help of 100 rpm speed, angular velocity can be calculated.

$$\text{Angular velocity of crank } (\omega) = \frac{2\pi n}{60}$$

With the above formula the angular velocity of the crank

$$\text{Speed } n = 100 \text{ rpm}$$

$$\text{Angular velocity } (\omega) = \frac{2\pi n}{60}$$

$$= \frac{2 \times 3.14 \times 100}{60}$$

$$= 10.46 \text{ rad/sec}$$

In this project we need to find the time taken for the crank to complete one rotation from given speed of the motor. The project is going to do the transient analysis basically the time-based action to find out the velocities of each link in Klann mechanism.

1000 rotations = 60 seconds

1 rotation = 0.6 seconds

Time taken for one rotation of the crank is = 0.6 sec

### 7. STRUCTURAL ANALYSIS

The above-mentioned data is useful only for the rigid dynamic analysis. The rigid dynamic analysis will help us to find the linear velocities, angular velocities and joint reactions of each leg link. And also find out the stress in links of the leg mechanism, deformations if any and fatigue analysis. Fatigue analysis is used to find out the life, damage and the safety factor.

The transient structural analysis requires torque for the crank. That means how much amount of torque is to be produced by the motor and thus transmitted to the crank.

Torque = 16 kg-cm

= 1569 N-mm

= 1.569 N-m

The above value of torque is considered as the input for the transient structural analysis. The results are shown in the pictures below in the further pages. Firstly, the pictures of the transient structural analysis results are shown.

The Fig. 11 represents the Preface of the analysis software i.e. ANSYS 16.2

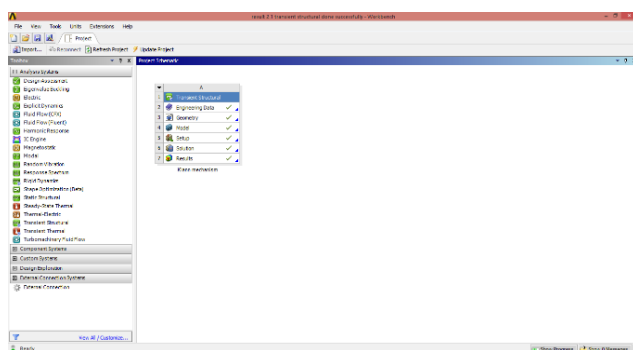

Fig 11: ANSYS Workbench 16.2 Interface

The Fig. 12 represents the Preface of the analysis in Mechanical Module.

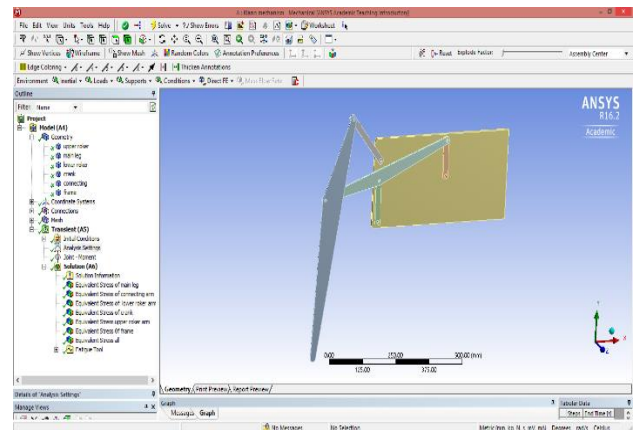

Fig 12: ANSYS mechanical module

The Fig. 13 represents the Meshing of the Single leg in the ANSYS Workbench.

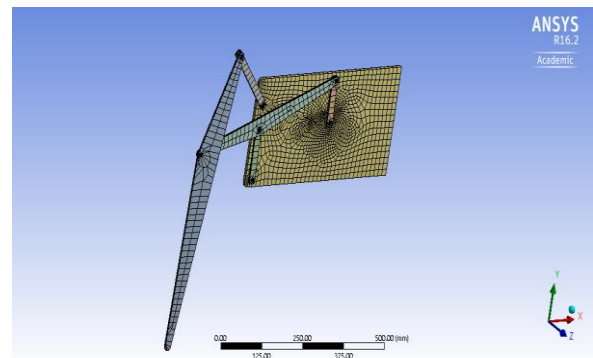

Fig 13: Meshing

The Fig. 14 represents Boundary Conditions applied to Single leg in the ANSYS Workbench.

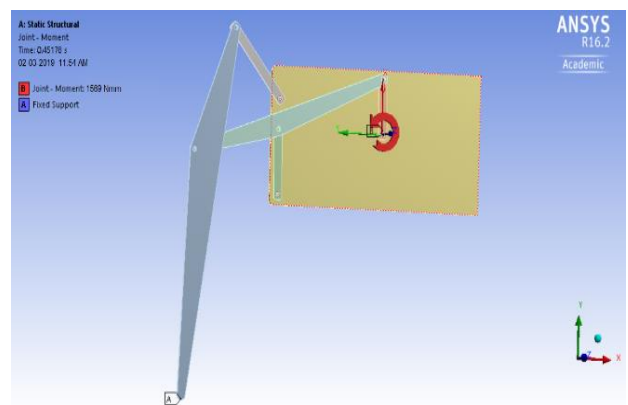

Fig 14: Boundary conditions

The Fig. 15 represents the Time consumed for testing

```

Total number of cores available      : 4
Number of physical cores available  : 2
Number of processes requested      : 1
Number of threads per process requested : 2
Total number of cores requested     : 2 (Shared Memory Parallel)

GPU Acceleration: Not Requested

Job Name: file
Working Directory: D:\study\walking robot\ANALYSIS\Analysis 2\_ProjectScratch\Scr3

Total CPU time for main thread      : 11492.1 seconds
Total CPU time summed for all threads : 20689.8 seconds

Elapsed time spent pre-processing model (/PREP7) : 0.1 seconds
Elapsed time spent solution - preprocessing : 0.7 seconds
Elapsed time spent computing solution : 11728.7 seconds
Elapsed time spent solution - postprocessing : 0.0 seconds
Elapsed time spent post-processing model (/POST1) : 0.1 seconds

Equation solver computational rate   : 6903.3 Mflops
Equation solver effective I/O rate   : 6673.2 MB/sec

Maximum total memory used           : 1165.0 MB
Maximum total memory allocated      : 3099.0 MB
Maximum total memory available      : 6 GB

----- END ANSYS STATISTICS -----

----- ANSYS RUN COMPLETED -----

Ansys Release 16.2      Build 16.2      UP20150629      WINDOWS x64

Database Requested(-db) 1024 MB  Scratch Memory Requested 1024 MB
Maximum Database Used   23 MB    Maximum Scratch Memory Used 1142 MB

CP Time (sec) = 20689.781      Time = 23:03:23
Elapsed Time (sec) = 11733.000 Date = 03/06/2016
    
```

Fig 15: Solution information

The Fig. 16 represents the Product tree of the Single leg in the ANSYS Workbench.

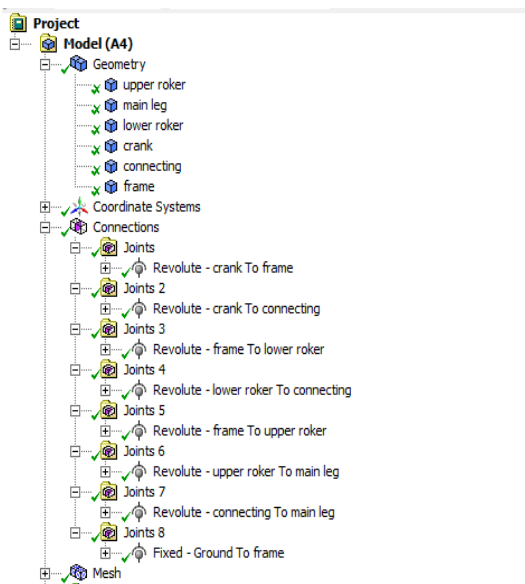

Fig 16: Product tree

In the Fig 17, Equivalent stress in the main leg, the blue shade represents the minimum value of stress & red shade represents the maximum value as the colour stress.

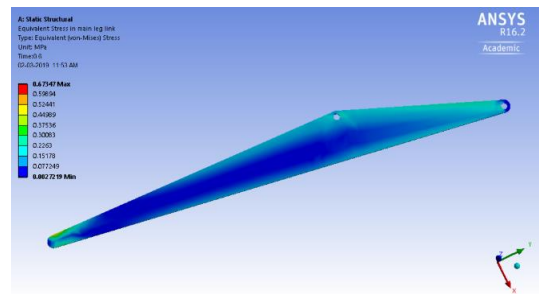

Fig 17: Main Leg

From the analysis of main leg, we understand that maximum stress is obtained at the point of contact with the ground, which will lead to deformation. To avoid it we need to add some material there. This will help to avoid stress there.

Fig. 18 represents Equivalent stress in the connecting arm.

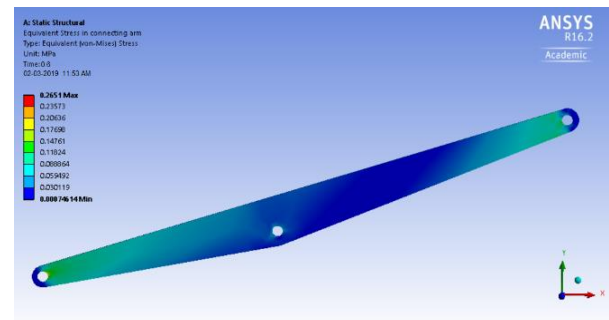

Fig 18: Connecting Arm

In this part, stresses are compressive stresses. It is due to the stresses are more at the points where the pivots connected to the main leg link and crank.

Fig. 19 represents Equivalent stress in the Lower Rocker Arm.

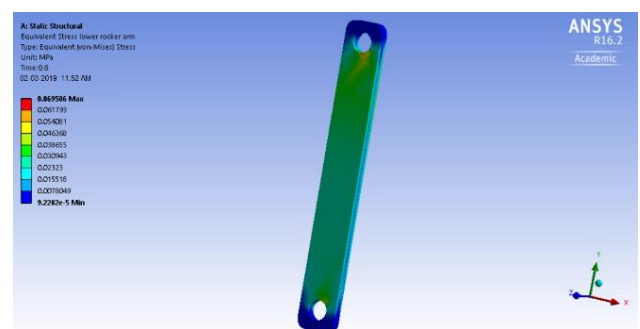

Fig 19: Lower Rocker Arm

Here also the stresses are more at the pivot points but less stress compared to other parts. Fig. 20 represents Equivalent stress in the Upper Rocker Arm.

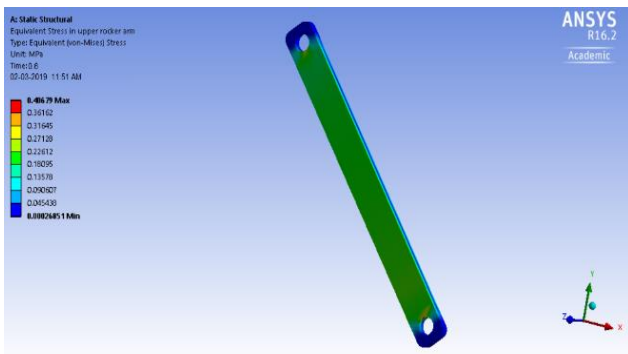

Fig 20: Upper Rocker Arm

Fig. 21 represents Equivalent stress in the Crank

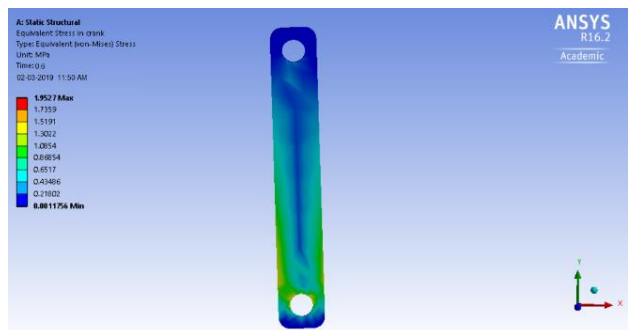

Fig 21: Crank

The stresses in the crank because this link is mounted on the shaft of the motor. Thus, this link is responsible for the entire motion in the leg mechanism.

Fig 22 represents Equivalent stress in the Frame

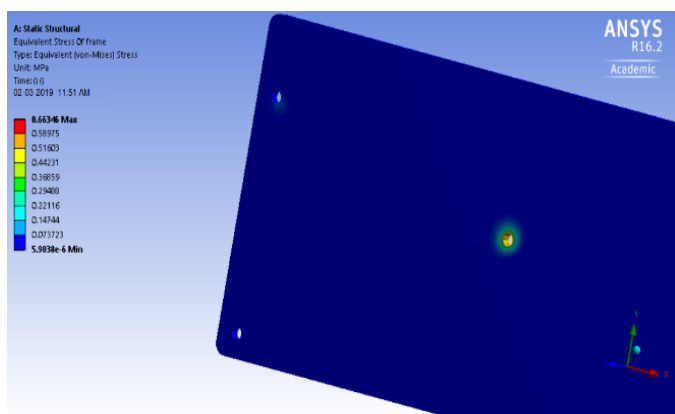

Fig 22: Frame

The maximum stress is at the hole where the crank and the motor shaft are connected.

Fig 23 represents Equivalent stress in the Entire Mechanism

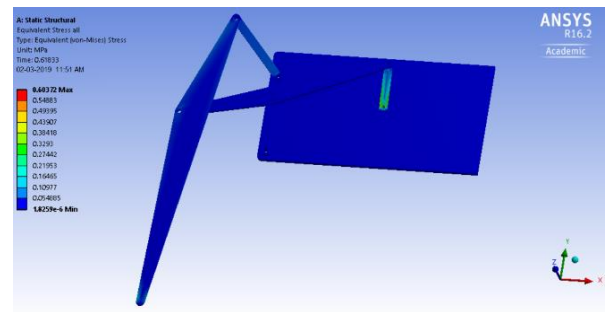

Fig 23: Entire Mechanism

### 8. OBSERVATIONS RECORDED FROM THE TRANSIENT STRUCTURAL ANALYSIS

The above images show the equivalent stress distribution for all the parts of the robot. The maximum stress in complete model is 1.9 Mpa and the minimum stress is 0.066 Mpa.

- Equivalent stresses in main leg link = 0.67Mpa
- Equivalent stresses in connecting arm = 0.27Mpa
- Equivalent stresses in crank = 1.95Mpa
- Equivalent stresses in lower rocker arm = 0.069Mpa
- Equivalent stresses in upper rocker arm = 0.40Mpa
- Equivalent stresses in frame = 0.66Mpa

### 9. DYNAMIC ANALYSIS

For analysis process, the project is going to fix a DC motor of 100 rpm with 16 kg torque.

$$\text{Angular velocity of crank } (\omega) = \frac{2\pi n}{60}$$

With the above formula the angular velocity of the crank

$$\text{Speed } n = 100 \text{ rpm}$$

$$\begin{aligned} \text{Angular velocity } (\omega) &= \frac{2\pi n}{60} \\ &= \frac{2 \times 3.14 \times 100}{60} \\ &= 10.46 \text{ rad/sec} \end{aligned}$$

Now we need to do the transient analysis of the model and for this we need to find time- based action of each link in klann mechanism. Thus, we need to find out time taken for crank to complete one rotation.

$$100 \text{ rotations} = 60 \text{ seconds}$$

$$1 \text{ rotation} = 0.6 \text{ second}$$

Thus, the time taken for one rotation of the crank is 0.6 sec

The above calculation values are used to find out the angular & linear velocity and accelerations of the link.

The Fig 24 represents the Velocity Analysis in the Crank.

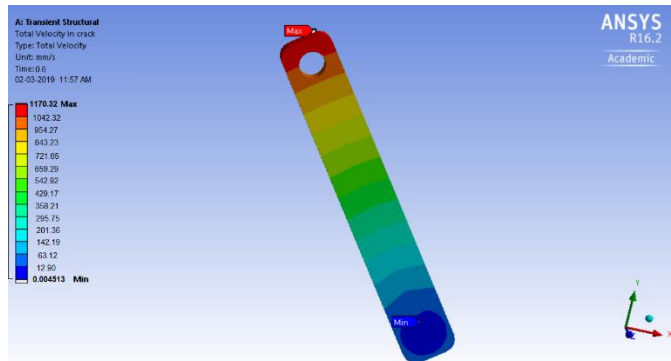

Fig 24: Crank

The Fig 25 represents the Velocity Analysis in the Lower Rocker Arm.

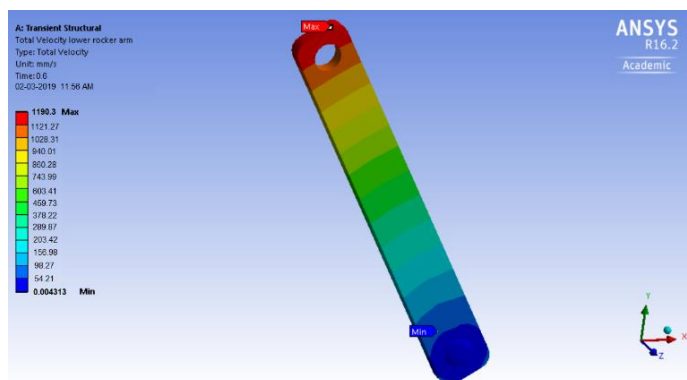

Fig 25: Lower Rocker Arm

The Fig 26 represents the Velocity Analysis in the Upper Rocker Arm.

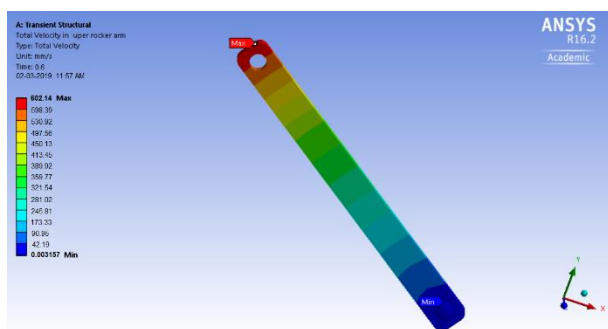

Fig 26: Upper Rocker Arm

The Fig 27 represents the Velocity Analysis in the Connecting Arm.

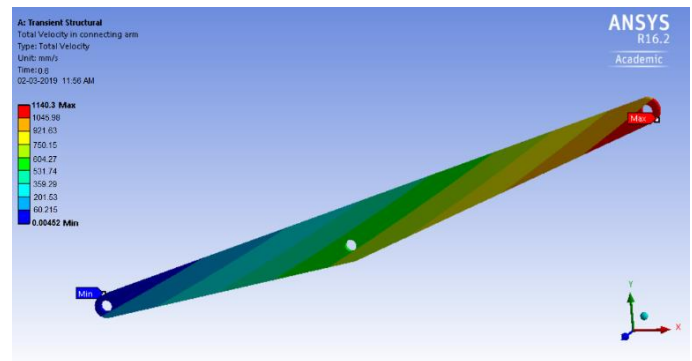

Fig 27: Connecting Arm

The Fig 28 represents the Velocity Analysis in the Main Leg Link.

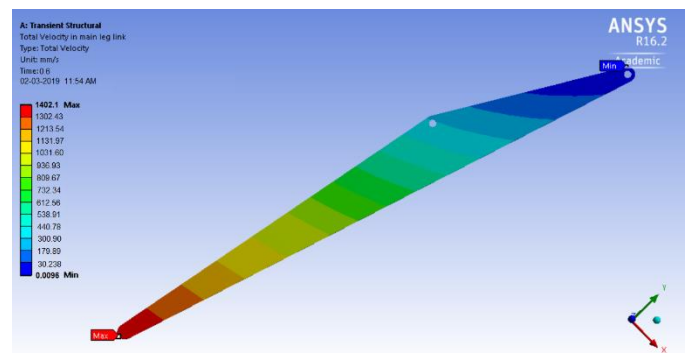

Fig 28: Main Leg Link

The Fig 24 to fig 28 show the results of the dynamic analysis of the project. Thus, dynamic analysis gives the total velocity of each link in the mechanisms.

## 10. THEORETICAL CALCULATIONS FOR ANALYSIS

Firstly, we are going to find out the velocity of the crank

$$\text{Angular velocity of crank } (\omega) = \frac{2\pi n}{60}$$

With the above formula the angular velocity of the crank

$$\text{Speed } n = 100 \text{ rpm}$$

$$\text{Angular velocity } (\omega) = \frac{2\pi n}{60}$$

$$= \frac{2 \times 3.14 \times 100}{60}$$

$$= 10.46 \text{ rad/sec}$$

$$\text{Linear velocity } (v) = \omega r \text{ m/sec}$$

$$= 10.46 \times 110(\text{mm})$$

$$= 1.1506 \text{ m/sec}$$



Graphical or Relative velocity method:

Scale 1cm = 1.1506/3 m/sec = 0.38353 m/sec

**(NOTE: For velocity diagram, graphical method is drawn in CAD software to get more accurate results & angles)**

Construction of Velocity diagram with CAD tools:

The Fig 29 represents the Perpendiculars to the Respected Links.

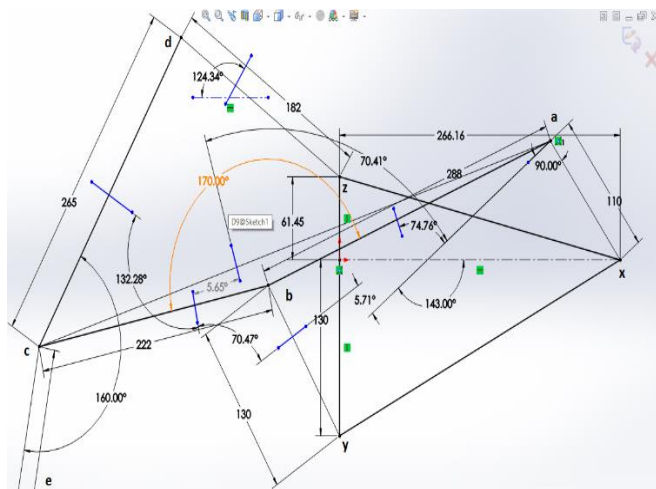

Fig 29: Perpendiculars to the Respected Links

The Fig 30 represents the Velocity Diagram including the dimensions.

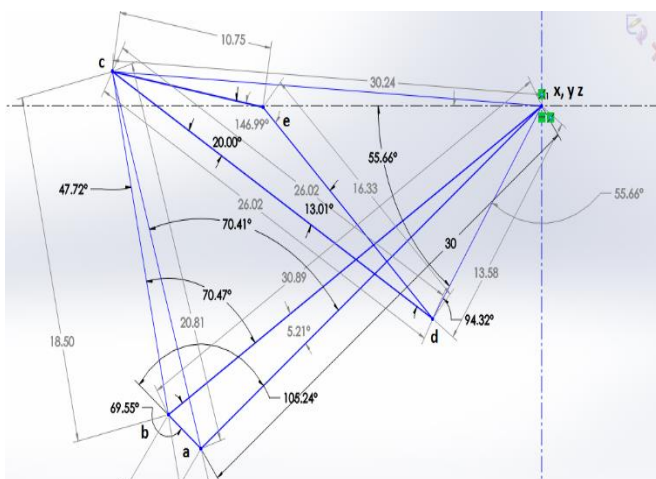

Fig 30: velocity diagram with dimensions

The Fig 31 represents the Velocity Directions in the Velocity Diagram.

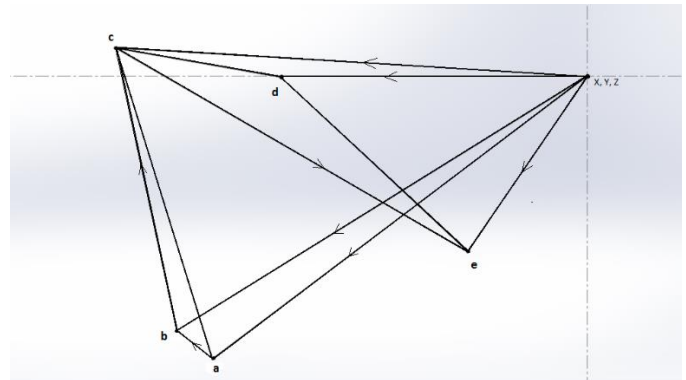

Fig 31: velocity direction

The velocity of link XA ( $V_a$ ) = 1.1506 m/sec

Velocity of link AB ( $V_{b/a}$ ) =  $0.29 \times 0.38353 = 0.1112$  m/sec

Velocity of link YB ( $V_b$ ) =  $3.09 \times 0.38353 = 1.1851$  m/sec

Velocity of point C ( $V_c$ ) =  $3.024 \times 0.38353 = 1.1597$  m/sec

Velocity of link DZ ( $V_d$ ) =  $1.358 \times 0.38353 = 0.5208$  m/sec

Velocity of link CD ( $V_{cd}$ ) =  $2.602 \times 0.38353 = 0.9979$  m/sec

**11. RESULTS COMPARISON**

Below Table 1 gives the comparison between the results of analytical data with the theoretical values. Here the project observed that velocities of the links in the walking mechanism.

The results theoretical and analysis are approximately matched with our theoretical results. But there is some difference btw the values. Below is the comparison between Theoretical and ANSYS results. There are some vast differences in some parts, but some parts are matched approximately. Due to some mistakes in the theoretical results, we are not able to get the exact solutions. The Table 1 represents the comparison between theoretical and ANSYS results.

Table 1: Comparison

COMPONENTS	THEORETICAL RESULTS (mm/sec)	ANSYS RESULTS (mm/sec)
crank	1150.6	1170
Upper rocker arm	520.8	602
Lower rocker arm	1185.1	1190
Connecting arm	1159.7	1140
Main leg link	997.9	1400

The theoretical values are less than the ANSYS values, because in theoretical calculations, length are taken up to the centers of joints. But in the process of designing of cad model, we are considering the diameter of holes for the joint and this results in extra velocities in ANSYS results.

## 12. OBSERVATION- STRESSES AND DEFORMATIONS

The Table 2 represents the Equivalent stress distribution and Deformation of the components.

Table 2: Stress and Deformation

COMPONENTS	EQUIVALENT STRESS (Mpa)	DEFORMATION (mm)
crank	1.952	0.00814
Upper rocker arm	0.069	0.00675
Lower rocker arm	0.405	0.02017
Connecting arm	0.265	0.00761
Main leg link	0.673	0.02001
frame	0.663	0.00127

## 13. CONCLUSIONS

- The final year project taught us many concepts of engineering. Some of the main concepts are Designing, kinematics, material science, CAD, manufacturing.
- The project started with the literature review that was the most important step of designing the robot. Various research papers, websites and books were considered before designing it.
- The manufacturing has started after research. After fabrication, the control mechanism was built. The control includes simple forward and backward motion.
- After the successful fabrication and control of robot, the robot was tested for its movement. The robot was hence built and completed to the best of our efforts with future possibility of improvement.

## 14. REFERENCES

- Ayers, Joseph; Witting, Jan; Olcott, Chris (2000a). "Lobster Robots". In: Proceedings of the International Symposium on Biomechanisms, pp. 960 – 975.
- Ayers, Joseph; Witting, Jan; Wilbur, Cricket; Zavracky, Paul (2000b). "Biomimetic Robots for Shallow Water Mine Countermeasures". In: Proceedings of the Autonomous Vehicles in Mine Countermeasures, pp. 235 – 275.

- Bares, John; Hebert, Martial; Kanade, Takeo (1989). "Ambler: An Autonomous Rover for Planetary Exploration". IEEE Computer. Vol. 6; pp. 18 – 26
- Binnard, Michael B.. (1995). "Design of a Small Pneumatic Walking Robot", M. Sc. Thesis. Massachusetts Institute of Technology.
- Bonvilain, Agnès (2003). "Microfabricated Thermally Actuated Microrobot". In: Proceedings of the 2003 IEEE International Conference on Robotics; pp. 2960 – 2965.
- Colbrunn, Robb William. (2000). "Design and Control of a Robotic Leg with Braided Pneumatic Actuators", M. Sc. Thesis. Case Western University – Department of Mechanical and Aerospace Engineering pp. 456-487.
- Fiorini, Paolo. (2000). "Ground Mobility Systems for Planetary Exploration". In: Proceedings of the 2000 IEEE International Conference on Robotics; pp. 908 – 913.
- Frank, A. (1968). "Automatic Control Systems for Legged Locomotion", USCEE Report No. 273; University of Southern California; Los Angeles, California.
- Hirose, Shigeo (1996). "Study on Roller-Walker (Basic Characteristics and its Control)". In: Proceedings of the 1996 IEEE International Conference on Robotics and Automation; pp. 3265 – 3270.
- Kaneko, Makoto; Mizuno, Akihiko (2002). "Torque Distribution for Achieving a Hugging Walk". In: Proceedings of the 2002 IEEE/RSJ International Conference on Intelligent Robots and Systems; pp. 2613 – 2618.
- Kikuchi, Fumitaka; Ota, Yusuke; Hirose (2003). "Basic Performance Experiments for Jumping Quadruped". In: Proceedings of the 2003 IEEE/RSJ Conference on Intelligent Robots and Systems; pp. 3378 – 3383.

## BIOGRAPHIES



Prof. Dr. S.N. Teli  
Professor, Mechanical Engineering,  
BVCOE, Navi Mumbai



Mr. Rohan Agarwal  
Final Year Student, Mechanical  
Engineering, BVCOE, Navi Mumbai



Mr. Devang Deepak Bagul  
Final Year Student, Mechanical  
Engineering, BVCOE, Navi Mumbai



Mr. Pushkar Badawane  
Final Year Student, Mechanical  
Engineering, BVCOE, Navi Mumbai



Mr. Riddhesh Rajesh Bandre  
Final Year Student, Mechanical  
Engineering, BVCOE, Navi Mumbai