

## RESCUE OF PSYCHOLOGICAL INFIRMITY PEOPLE USING WIRELESS NETWORK

A. Ramadevi<sup>1</sup>, A. Sanmugapriyan<sup>2</sup>, D.Tamilaruvi<sup>3</sup>, Dr. J. Mohan<sup>4</sup>

<sup>1,2,3</sup>Student, Department of ECE, Valliammai Engineering College, Tamilnadu, India.

<sup>4</sup>Associate professor Department of ECE, Valliammai Engineering College, Tamilnadu, India.

\*\*\*

**Abstract** - For the indoor location many device exist that can be used with diverse technologies (Bluetooth, Ultrasound). Apart from adding functionalities to the existing network or the presence of detection, the range estimation is the base to create a system of indoor positioning. The personal area network are network for interconnection of devices near a person that habitually have smaller reaches of 10 meters. In this article, used to provide the protection for psychological infirmity people. We can create intra network between psychological infirmity people with RF communication. Main objective is to reduce the missing rate of psychological infirmity people with the coverage area of 400 meters that is probably about 433MHZ

**Index Terms** - Atmega328 NANO microcontroller, Atmega328 UNO microcontroller, RF transmitter, RF receiver, Power source, 16x2 LCD, Active Buzzer.

### 1. INTRODUCTION

Nowadays, many people are missing without having the proper protecting device. So, we have to introduce a one protecting device for those people. Our protecting device not only applicable for the psychological infirmity people. It can also applicable for children, Aged people, Acquist and Blind people also. Cases on kidnapping child frequently happened in public area. Since technology is updated very fast, certain flaws occurs with existing systems like indoors [1] The Arduino based home automation system using RF transceiver for old aged people is the famous and most used technology in this world. In this paper they are using the Arduino microcontroller in the basis of home appliances are controlled through the radio frequency signal. [2]The blind people are involving many struggles. The world health organization (WHO) reported that they are 285 million visually impaired people. The number of blind people over 60 years old is increasing by 2 million per decade. Unfortunately ,all these numbers are estimated to be doubled by 2020[3]one of the earliest location estimation systems in the area of WSNs is the cricket indoor location support system developed at MIT, which uses ultra sound transmitters and embed receivers in the objects being located.it uses the RF signal for time synchronization and delineation of the time during which the receiver considers the sound waves it receives[7]In our country, every year the missing rate of psychological

infirmity people was gradually increasing. In which our project is to reduce the missing rate of psychological infirmity people.

### 2. EXISTING SYSTEM

Many system exist that can be used with diverse technologies like Bluetooth, ultra sound for the indoor location. This can be used only for the indoor positioning. It can be used only for the smaller reaches of 10 meters. Surveillance camera used only for the specified range of distance that is very short distance. Security guards for psychological infirmity people.



### 3. PROPOSED SYSTEM

In our project, the main goal is to protect the psychological infirmity people using the wireless network. In which, our proposed system contains the Atmega328 NANO microcontroller, Atmega328 UNO microcontroller, RF transmitter, RF receiver, LCD, Active Buzzer and Arduino IDE to we done the project as well. According to this project, we can use the two Atmega328 NANO at the transmitter side and another one at the receiver side that is Atmega328 UNO. We can create the intra network between the people. The Transmitter Arduino size was very small because here they used only for transmitting the signal towards the receiver side. The Receiver side Arduino is much bigger compared to transmitter side. Because the Receiver Arduino will contains the details about the psychological infirmity people (people name, age, id). After that, the transmitter programming code can be dumped into the Atmega328 NANO microcontroller and the receiver program can be dumped into the Atmega328 UNO microcontroller. Client side Atmega328 NANO microcontroller will send the data through the RF transmitter then it will receive the information via the RF receiver to Atmega328 UNO microcontroller. For every 10 sec, the transmitter Arduino will continuously send the

information to the receiver Arduino. The information is like (person name, age and id). For every 10 sec, it will check the people within the coverage area or not. We fixed the particular range frequency (RF transmitter frequency 433MHZ). The psychological infirmity people were cross the particular frequency range, it will wait for another 10sec they are not yet come at the particular sec means the Active Buzzer will give the alarm sound and it will be displayed (person name, age, id) in the 16x2 LCD.

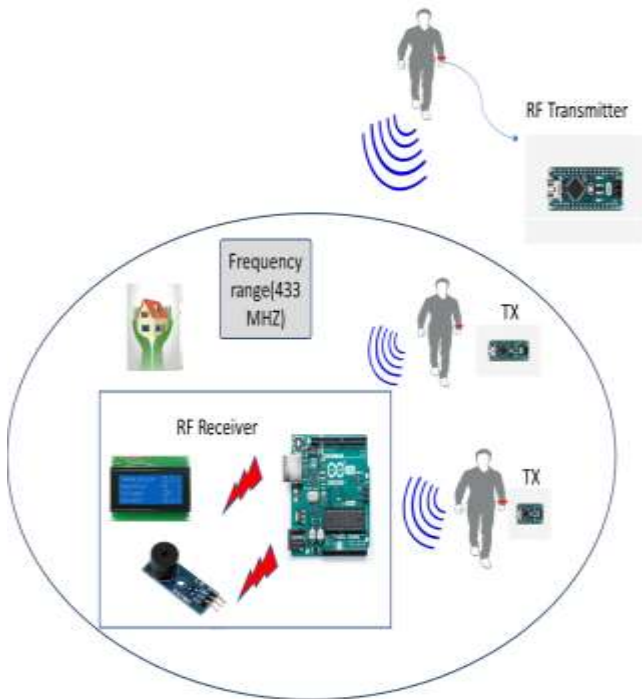

**4. Block Diagram**

**Block Diagram(Transmitter)**



**Block Diagram(Receiver)**

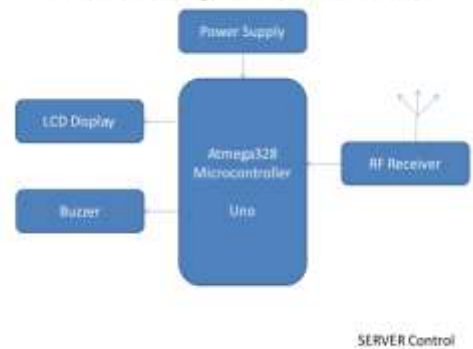

*Flow Chart*

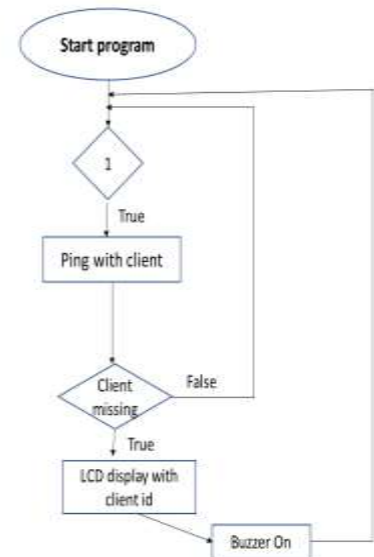

**5. Hardware requirements**

- Atmega328 UNO
- Rf transmitter
- Rf receiver
- LCD display
- Power source
- Buzzer

**6. Software requirements**

- Arduino IDE(code compiling software)
- Embedded C

## 7. HARDWARE DETAILS

### 7.1 Arduino UNO

Arduino is a single-board microcontroller make the application more accessible which are interactive objects and its surroundings. The hardware features with an hardware board designed for an 8-bit Atmel AVR microcontroller or a 32-bit Atmel ARM. Current model consists of a USB interface, 6analog input pins and 14 digital I/O pins that allows the user to attach various extension boards. The Arduino Uno board is a ATmega328 based microcontroller. It has 14 digital input/output pins, 6 can be used as PWM outputs, an ICSP header, 16mhz ceramic resonator a USB connection, 6analog inputs, a power jack and a reset button. This contains all the required support for microcontroller. In order to get started, they are simply connected to a computer with a USB cable or with AC-to-DC adapter or battery. Arduino Uno Board varies from other boards and they will not use FTDI USB-to-serial driver chip. It is featured by the Atmega16U2 (Atmega8U2 up to version R2) programmed as a USB-to-serial converter. Sensors, actuators, and electronic components on a common silicon substrate through micro-fabrication technology. The electronic components are fabricated using integrated circuit process sequences (e.g. CMOS, Bipolar, or BICMOS processes). The micromechanical components are fabricated using compatible "micromachining" processes in which selected parts of the silicon wafer can be etched. Also, it can add new structural layers to form the mechanical and electromechanical

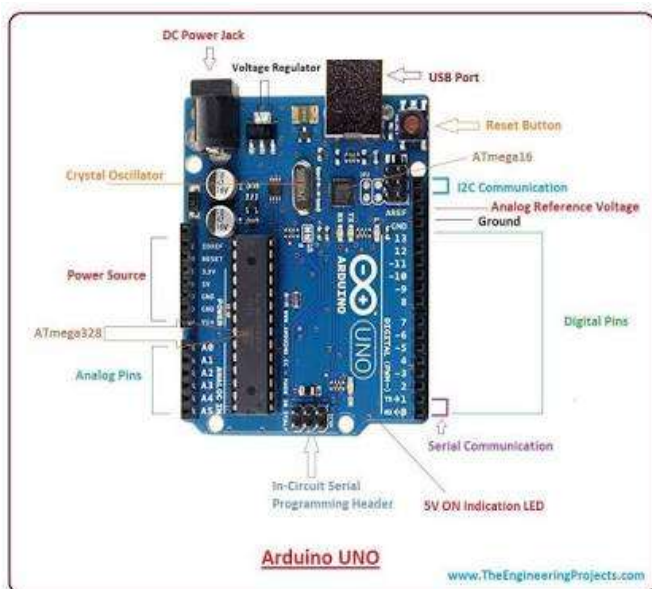

### 7.2 Arduino NANO

The Arduino NANO is small, and it is based on the ATmega328P (Arduino NANO 3.X).It has more or less the same functionality of the Arduino, but it has a different package .The DC power Jack will be lacks

It should always work with the MINI USB cable

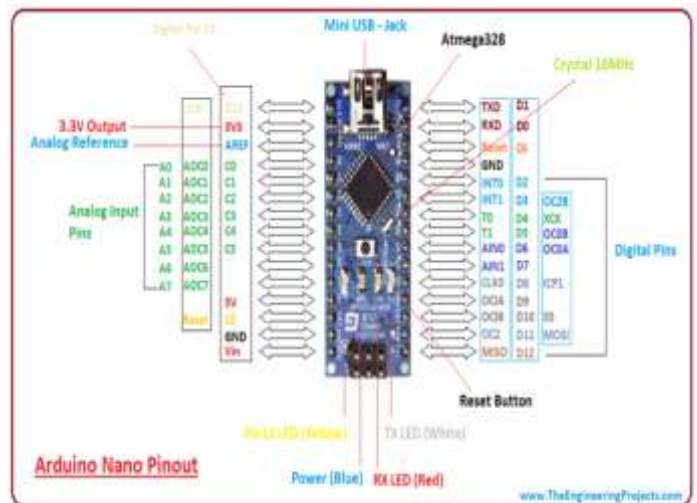

### 7.3RF Transmitter and RF Receiver

RF Module (Radio frequency Module) is used to transmit or broadcast the signal towards the receiver side which is a small electronic device.. The receiver used to receive the transmitted Radio signal between the two devices. It is often desirable to communicate with the other system wirelessly. RF communicator incorporates the Transmitter and receiver. The RF receiver frequency is about 433MHZ and the receiver typical frequency 105Dbm-Supply current of receiver 3.5mA. The operating voltage is about 5V.Transmitter frequency range is about 433.92MHZ.Supply voltage of transmitter is 3v~6V.

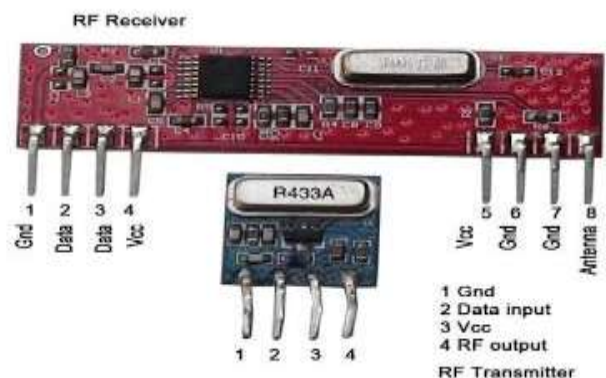



### 7.4 LCD

The LCD 16x2 is a flat panel display. An LCD is an electronic display module which has the liquid crystal to produce a visible image. Each LCD character is probably displayed in a 5x7 pixel. The term 16x2 means it will display 16 characters can be displayed in each of the two rows. It will display the name, age, id



### 7.5 Active Buzzer

It's an Active buzzer. Which is basically a predefined frequency that is (2300 +300 HZ). The active Buzzer needs a DC power. It can produce a varied tone from oscillating input signal. Which produces a sound by itself. It was generating a tone using an internal oscillator. So, it needed a DC voltage. The main advantage of this Active Buzzer is, It will produce a sound from the Buzzer connected to the microcontroller, such as Arduino, or high output in the connected pin.

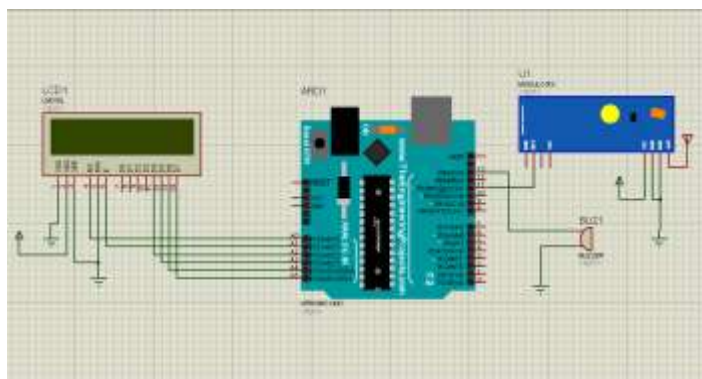

## 8. SOFTWARE DETAILS

### 8.1 ARDUINO IDE

Arduino is a micro-controller development board series - Uno, Nano mega etc. Now, any micro-controller (here it is the at mega 328 IC on the Arduino Uno or At mega 1280 on Arduino Mega) that needs to be programmed is fed with a hex code version written in high level language. So, Arduino development boards are fed with the code via Arduino IDE.

IDE (Integrated Development Environment) is a software that enables better and assisted code editing, compiling and debugging. The Arduino IDE works on the Java Platform. You can co-relate this to Eclipse, the language java has different IDEs that ease the usage of the language for a particular purpose. However, Eclipse doesn't support the functions and commands that work on Arduino board. So, this Arduino IDE has inbuilt functions and commands that though work on Java platform, are customised to run on the Arduino development.

## 9. RESULT

Reduction of missing rate in the caring home. Security and protection for psychological infirmity people

Depending upon our requirement we can extend the frequency range. Area coverage for psychological infirmity people. Monitoring and safety measurement for children and blind people also.

## 10. CONCLUSION

In this system, we proposed a protecting device for Psychological infirmity people. This device to we can reduce the missing rate of psychological infirmity people. This system not only applicable for the psychological infirmity people. It can also applicable for Children, aged people and acquist. This is used in many applications. This method to we can avoid the security guards for those people. It's very fastest method to finding those people and security method too.

## 11. REFERENCES

1. Murizah Kassim, Siti Hazirah Salih, "Adaptive distance alert safety system (ADASS) on child tracking using Arduino" vol 11, No. 23, December 2016.
2. K. Shanmugam, S. Vidhya, P. Susan peace, "Arduino based home automation using RF transceiver for old aged people" 2016
3. Wafa Elmannai and Khaled Elleithy, "Sensor-Based Assistive Devices for Visually-impaired people: Current Status, Challenges and Future Directions".

4. R.Virrankoski and M.Elmusrati,"Improving RSSI Based Distance Estimation for 802.15.4 Wireless Sensor Network".

5. Pablo corral and V.Almenar,"Distance Estimation System Based On Zigbee".

6. Azzidine Boukerche."Localization System for Wireless Sensor Network".

7. Mohit saxena, puneet Gupta,"Experimental analysis of RSSI-based Location Estimation in wireless sensor network"