

Implementation of Arduino UNO based Two Directional [2D] Plotter

Sheetal N.Patil¹, Prashant G. Patil²

¹Assistant Professor, Department of Information Technology, R C Patel Institute of Technology, Shirpur (M.S) India

²Assistant Professor, Department of Electronics & Communication, R C Patel Institute of Technology, Shirpur (M.S) India

Abstract – In this project, with the advancement of technology, demand for plotter machines in Educational Institutions such like as blind student educational institute, this project also used for the handicapped and temporary fractured people. This paper will present an affordable model of a plotter machine which is able to write the text which is speak in AMR voice Apk or. At first the user needs to convert any text file into G code using Ink space software and then feed it to the machine using Processing software. Arduino uno with an ATmega328P microcontroller is used as the control device for this project. The microcontroller converts G-code into a set of machine language instruction to be sent to the motor driver of the 2D plotter. But the G-code is send to plotter using the Bluetooth module, First the voice is recognized using android application name is AMR voice, this application available on play store of mobile.

Key Words: Bluetooth module, Arduino Uno, Stepper motor, Drivers, Servo motors

1. INTRODUCTION

In the present study, the X-Y plotter is designed to recording and plotting two-dimensional data on a rectangular coordinate system. The material selection of the mechanism was made considering the cost and wide range of applications such as servomotor. Servo motor can be differentiated through the cost, peak torque capability, speed range to compromise the standard and application of the system. Park, discuss the dynamics of a dual-drive servo mechanism and develops an XY gantry model consisting of two motors for Y control with another motor sliding the gantry in the X direction. The design uses two parallel rails for Y-motion with a bar spanning across the rails which holds the end effectors of the system. In the other hand, the accuracy of plotting is the main issue to be concerned on the fabrication of X-Y plotter.

Few papers have been devoted to plotters in term of their adjustment methods on the accuracy and movement of plotter [10-14]. The X-Y plotter system is a more simplified system comparing to the 2D PLOTTER system since 2D PLOTTER system is running on 3 axis direction and the programming is more complicated Nevertheless, the coding for the 2D PLOTTER system which is the G-Code 2nd Integrated Design Project Conference (IDPC) 2015, Faculty of Mechanical Engineering, University Malaysia Pahang, 11 Dec 2015 programming can be modified and simplify it to

the 2 axis coding movement. G-Code is the generic name for a control language for machines. It is a function to tell the machine to move to various points at the desired speed, control the spindle speed, and turn on and off various coolants. In this X-Y plotter system, G-Code is employed by the part programmer to specifying the coordinates of the point to be moved and giving the normal vector to the surface at that point. For the core system, Arduino system is most familiar by the inventor and mainly used in most of the electronic components because of is compatibility of the system with the hardware. Meanwhile, low cost and easily controlled function of the Arduino system contributed on simplifying the building circuit of the microcontroller in the X-Y plotter Dec 2015.

The 2d plotter exist everywhere but in project the data will send through the Bluetooth module. Interface the plotter with Bluetooth and send voice data means G-code through the android application name as AMR voice Apk.

2. LITERATURE REVIEW

Jae Wook Jeon and Young Youl Ha, A Generalized Approach for the Acceleration and Deceleration of Industrial Robots and 2D PLOTTER Machine Tools, IEEE Transactions on Industrial Electronics, Vol. 47, No. 1, February 2000, pp. 133-139 Many techniques for the acceleration and deceleration of industrial robots and computer numerical control (2D PLOTTER) machine tools have been proposed in order to make industrial robots and 2D PLOTTER machine tools perform given tasks efficiently. Although the techniques selecting polynomial functions can generate various acceleration and deceleration characteristics, the major problem is the computational load. The digital convolution techniques are more efficient than the techniques selecting polynomial functions. However, neither velocity profiles of which the deceleration characteristics is independent from the acceleration characteristics nor those of which the acceleration interval is different from the deceleration interval can be generated by the digital convolution techniques. This paper proposes a generalized approach for generating velocity profiles that cannot be generated by the digital convolution techniques. According to the desired characteristics of acceleration and deceleration, each set of coefficients is calculated and is stored. Given a moving distance, and acceleration and deceleration intervals, a velocity profile having the desired characteristics of acceleration and deceleration can be

efficiently generated by using these coefficients. Several velocity profiles generated by the proposed technique will be applied to one single-axis control system.

Allen G. Morinec, Power Quality Considerations for 2D PLOTTER Machines: Grounding, IEEE Transactions on Industrial Electronics, Vol. 38, No. 1, January/February 2002. Computer numerical control (2D PLOTTER) machines are used to shape metal parts by milling, boring, cutting, drilling, and grinding. A 2D PLOTTER machine generally consists of a computer controlled servo-amplifier, servo-motors, spindle motor, and various tooling. The machine can be programmed to shape a part by use of a front control panel. More sophisticated models allow a computer-aided design drawing to be uploaded to the machine. The electronic components within a 2D PLOTTER machine are particularly sensitive to the grounding techniques used in the electrical supply to the machine. Malfunction, degradation, and damage to the electronics can often be traced to supplemental ground rods and lightning strikes to earth. Production downtime, product loss, and expensive repair bills result. With the wide-spread use of 2D PLOTTER machines across the world, these problems have become a significant financial concern to many 2D PLOTTER machine users and their electric utility companies. This paper begins with a brief explanation of the fundamentals of service and equipment grounding. The basic design of 2D PLOTTER machines is also explained. Based on a survey of several 2D PLOTTER machine representatives, the paper will explore the common grounding techniques recommended by many 2D PLOTTER machine tool builders with particular emphasis on the ground-rod problem. In addition, several actual case studies that support the ground-rod problem will be described. Finally, a recommended powering and grounding practice is presented to help eliminate power quality related operating problems with 2D PLOTTER machines while maintaining the safety requirements of electrical codes.

Venkatram Ramachandran, Evaluation of Performance Criteria of 2D PLOTTER Machine Tool Drive System, IEEE Transactions on Industrial Electronics.

The stability, steady-state error analysis, damping factor, and setting time of discrete data drives for computer numerical control (2D PLOTTER) machine tools are analysed to obtain the necessary information for the design of a practical system. The stability of the drive is reviewed using Jury's test and the Mitrovic criterion. The variation of damping factor and settling time with respect to system parameters are presented based on the Mitrovic criterion.

3. PROPOSED SYSTEM

2D plotter is a machine that can control a plotting instrument (such as a pen or a cutting tool like a blade or a laser) over two axes in an accurate, precise manner. Computer Numerical Control (CNC) machines are very accurate XY plotters than can be used for anything from decorating cakes

to cutting steel plates into very precise shapes and sizes. I wanted to make a drawing robot that would be able to draw the contours of a human face, so I decided to experiment with some very basic stepper motors and a cheap toy plotter that I bought on the Internet. Unfortunately, the plotter itself is so poorly manufactured that it is useless as a drawing tool, but the whole project gave me much insight into the steps needed to design a build a proper computer controlled plotting machine. Since everyone is likely to use a different hardware setup to build a plotter, my emphasis is mostly on the electronics and software code needed once the hardware has been built properly.

3.1 Arduino Uno ATmega328P

The Uno is a microcontroller board based on the ATmega328P. It has 14 digital input/output pins (of which 6 can be used as PWM outputs), 6 analog inputs, a 16 MHz quartz crystal, a USB connection, a power jack, an ICSP header and a reset button. It contains everything needed to support the microcontroller; simply connect it to a computer with a USB cable or power it with a AC-to-DC adapter or battery to get started. Anyone can tinker with the UNO without worrying too much about doing something wrong, worst case scenario you can replace the chip for a few dollars and start over again. Uno means one in Italian and was chosen to mark the release of Arduino Software (IDE) 1.0. The Uno board and version 1.0 of Arduino Software

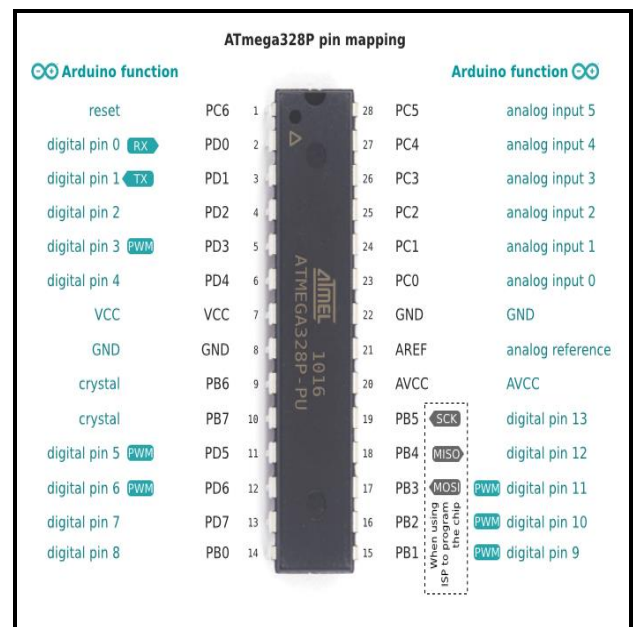

Fig -1: Pin Diagram of Arduino Uno ATmega328P

(IDE) were the reference versions of Arduino, now evolved to newer releases.

The Uno board is the first in a series of USB Arduino boards, and the reference model for the Arduino platform; for an extensive list of current, past or outdated boards see

the Arduino index of boards. The board features an Atmel ATmega328 microcontroller operating at 5 V with 2Kb of RAM, 32 Kb of flash memory for storing programs and 1 Kb of EEPROM for storing parameters. The clock speed is 16 MHz, which translates to about executing about 300,000 lines of C source code per second. The board has 14 digital I/O pins and 6 analog input pins. There is a USB connector for talking to the host computer and a DC power jack for connecting an external 6-20 V power source, for example a 9 V battery, when running a program while not connected to the host computer. Headers are provided for interfacing to the I/O pins using 22 g solid wire or header connectors

3.2 Stepper Motor with Drive

A stepper motor is a type of DC motor which has a full rotation divided in an equal number of steps. It is a type of actuator highly compatible with numerical control means, as it is essentially an electromechanical converter of digital impulses into proportional movement of its shaft, providing precise speed, position and direction control in an open-loop fashion, without requiring encoders, end-of-line switches or other types of sensors as conventional electric motors require.



Fig -2: Stepper Motor with Drive

The null position of the rotor is given by the total angular displacement resulting from the number of steps performed. This position is kept until a new impulse, or sequence of impulses, is applied. These properties make the stepper motor an excellent execution element of open-loop control systems. A stepper motor does not lose steps, i.e. no slippage occurs, it remains synchronous to control impulses even from standstill or when braked, thanks to this characteristic a stepper motor can be started, stopped or reversed in a sudden fashion without losing steps throughout its operation.

3.3. Servo Motor



Fig -3: Servo Motor

A servo motor is an electrical device which can push or rotate an object with great precision. To rotate an object at some specific angles or distance, servo motor is used. It is just made up of simple motor which run through servo mechanism. If motor is used is DC powered then it is called DC servo motor, and if it is AC powered motor then it is called AC servo motor. We can get a very high torque servo motor in a small and light weight packages. Due to these features they are being used in many applications like toy car, RC helicopters and planes, Robotics, CNC Machine etc. The position of a servo motor is decided by electrical pulse and its circuitry is placed beside the motor.

3.4 Bluetooth Module

In the project the Bluetooth module used for sending the G-codes to the plotter. HC-05 is a Bluetooth device used for wireless communication. It works on serial communication (UART).

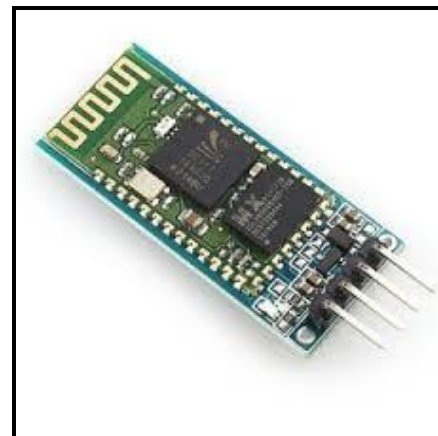

Fig -4: Bluetooth Module

- It is a 6 pin module. • The device can be used in 2 modes; data mode and command mode. • The data mode is used for data transfer between devices whereas command mode is used for changing the settings of the Bluetooth module.
- AT commands are required in command mode.
- The module works on 5V or 3.3V. It has an on board 5V to 3.3V regulator.
- As HC-05 Bluetooth module has 3.3 V level for RX/TX and microcontroller can detect 3.3 V level, so, no need to shift transmit level of HC-05 module.

4. RESULTS

The pen of the machine can be replaced by a laser to make it work like a laser engraving or cutting machine. Engraving machine can be used on wood. The pen can also be replaced with a powerful drill so that it can be used for both milling and drilling purposes. The servo can be replaced

with a stepper motor and the pen with a 3-D pen to make it a 3-D printer which can print objects with dimensions. By extrapolation of the axes, the working area of the machine can be extended keeping the algorithm unaltered.

A text file has been designed and sent to the CNC plotter for drawing the text. The original file and the plotted files are shown in the Fig 5.

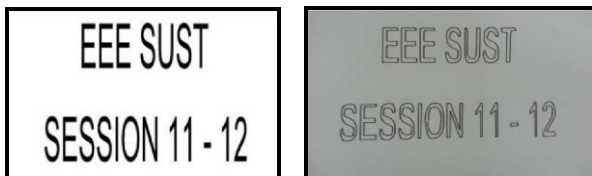

Fig- 5: Comparison of text file (a) original text (b) plotted text

5. SOFTWARE

5.1. Ink-scape

Ink-scape is used to design the plotted diagram or text. In this project by using this software G-code file of a selected image or text is created. G-code is a commonly used numerical control programming language which includes X,

Y, Z coordinates. Creating G-Code File Using Ink-scape. The CNC plotter of our project will work within 20cm20cm area. So we choose the document properties of the Ink-scape 40cmx40cm (Width Height) which is four times the working area of the plotter because the plotter can draw only in the first quadrant. So we have initially kept the axes at the nearest end of the motors which is considered as origin to easily modify the design. Working area of the plotter because the plotter can draw only in the first quadrant. So we have initially kept the axes at the nearest end of the motors which is considered as origin to easily modify the design. In Fig. the working area of CNC plotter is shown with the text written in the pre-defined area.

The text is selected using cursor and then select object to path from the drop down window to save the G code form of the selected text. To create G-code of an image, the file must have a transparent background.

The image should be dragged into the selected area then select trace bitmap from drop down window to create a transparent image. Scans are selected as 8 and Edge detection is selected to create black white image. After adding this transparent image in the predefined area wave used object to path command to create the G-code file of the selected image by following the steps described earlier.

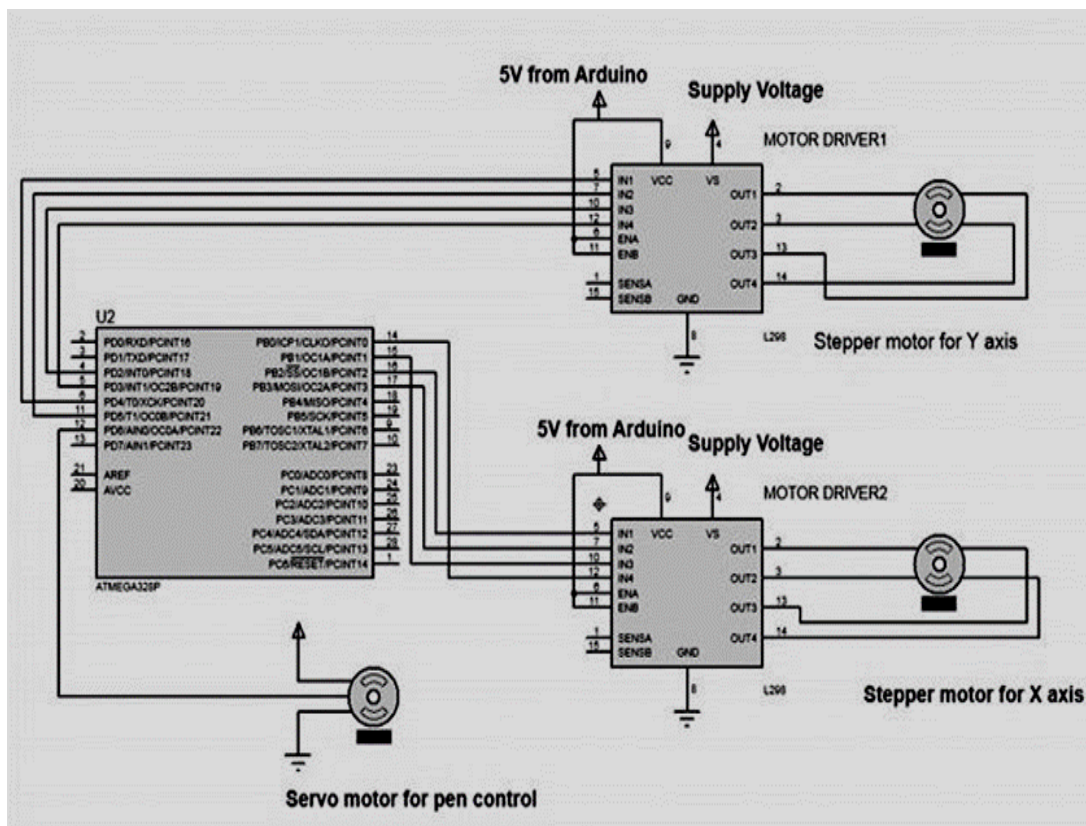

Fig -6: Experimental Circuit Diagram

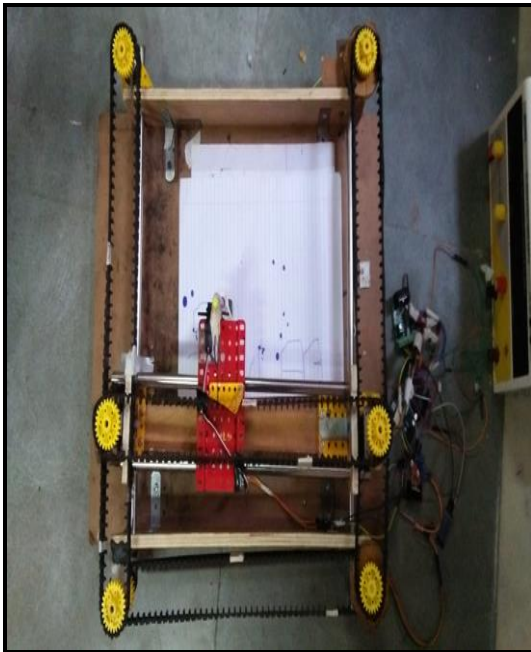

Fig -7: Experimental Circuit Diagram

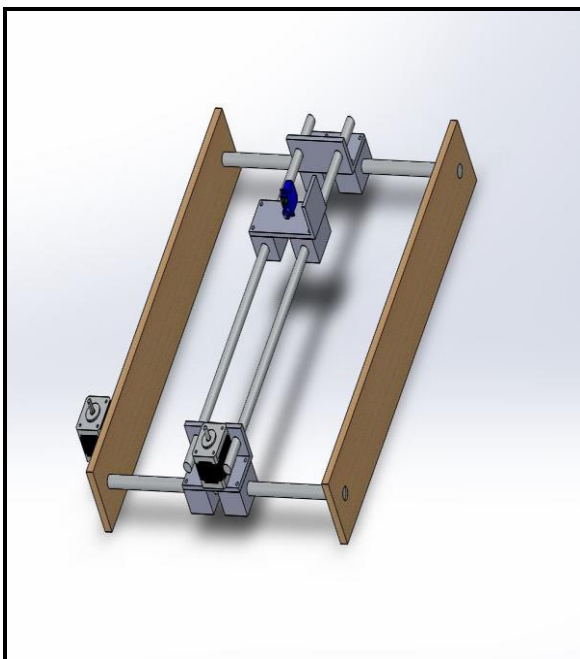

Fig -7: 2-D Plotter Chassis

5.2 Processing

Processing is open source programming language software which is used for electronic drawings. GTCRL processing program is used to send G-code file from user interface to CNC plotter. The Fig. 6 shows the user interface of processing 2.2.1 software after running GTCRL program. The port of Arduino Uno is selected by pressing P button on keyboard hence "G" button is used to upload our desired G-code file. Immediately CNC machine will start sketching

selected G-code file. Sketching will stopped by pressing "X" button.

6. CONCLUSION & FUTURE SCOPE

This project is about building a mechanical prototype of a plotter machine which is able to write text on a given solid surface. It consumes low power and works with high accuracy due to precise controlling of stepper motors. This is a low cost project as compared to other product. It is made with easily available components and spare parts. It is designed for private manufacturing and small scale applications in educational institutes.

The machine is designed with a very simple construction scheme and can be carried anywhere without much effort. The algorithm used is simple. The pen can be replaced with a pinhead or laser head or any other tool for different purpose of use. Software that has been used is open source and user friendly. The pen of the machine can be replaced by a laser to make it work like a laser engraving or cutting machine. Engraving machine can be used on wood. The pen can also be replaced with a powerful drill so that it can be used for both milling and drilling purposes.

The servo can be replaced with a stepper motor and the pen with a 3-D pen to make it a 3-D printer which can print objects with dimensions. By extrapolation of the axes, the working area of the machine can be extended keeping the algorithm unaltered.

REFERENCES

- [1] Madekar, kajal j. " Automatic mini CNC machine for PCB drawing and drilling." (2016).
- [2] Linggarjati, jimmy, and Ronda Hedwig. "manually interchangeable heads of homemade computer numerical control (CNC) machine." internetworking Indonesia journal 1.1 (2013).
- [3] M.R. Wright, D.E. Plats, D.B. French, G. DuPont, "Head, CNC control system patents, US patent 545393, Sep 26, 1995.
- [4] G. H. Joseph and D. J. Logan, "XY plotter & quot; Google Patents, 1966.
- [5] M. Sakamoto, R. Magumo, T. Ishihara, and T. Kobari, "XY plotter for non-perforated paper & quot; ed: Google Patents, 1990.
- [6] J. Yeiser, "XY plotter & quot; ed: Google Patents, 1973.
- [7] R. Krishnan, " Selection criteria for servo motor drives & quot; Industry Applications, IEEE Transactions on, pp. 270-275, 1987.

- [8] R. D. Bloom, J. V. Gac, and E. T. Kozol, & quot; Programmable servo motor speed control apparatus & quot; ed: Google Patents, 1986.
- [9] H.K. Park, S.S. Kim, J.M. Park, T.Y. Cho, and D. Hong, & quot; Dynamics of dual-drive servo mechanism & quot; in Industrial Electronics, 2001. Proceedings. ISIE 2001. IEEE International Symposium on, 2001, pp. 1996-2000.
- [10] M. Iri, K. Murota, and S. Matsui, & quot; an approximate solution for the problem of optimizing the plotter pen movement & quot; in System Modeling and Optimization, Springer, 1982, pp. 572-580.
- [11] G. Ghiani, D. Laganà, and R. Musmanno, & quot; A constructive heuristic for the undirected rural postman problem & quot; Computers & operations research, vol. 33, pp. 3450-3457, 2006.
- [12] 12. H. J. Gerber, & quot; Error correcting system and method for use with plotters, machine tools and the like & quot; Google Patents, 1971.
- [13] G. Ghiani and G. Improta, & quot; The laser-plotter beam routing problem & quot; Journal of the Operational Research Society, vol. 52, pp. 945-951, 2001.
- [14] 14. M. Sakamoto, R. Nagumo, and T. Ishihara, & quot; XY plotter drive roller arrangement & quot; Google Patents, 1987.