

# Design and Development Pedal Operated Multi-crop Thresher with Vibrating Screen and maize De-seeder

Mohite Poonam<sup>1</sup>, Aga Toffik<sup>2</sup>, Nalawade Rohit<sup>3</sup>, Yadhav Santosh<sup>4</sup>

<sup>1,2</sup>Student, Jaywant college of engineering and management, K.M.Gad, shivaji university

<sup>3,4</sup>Student Jaywant college of engineering and management, K.M.Gad, shivaji university

\*\*\*

**Abstract:** The main objective of this study was to design and fabricated a Pedal operated multi-crop thresher for threshing, separating and cleaning grains. The major components of the machine includes the separation and cleaning units. threshing operation is achieved by rotational motion of the pulley. the machine is simple, compact in size and the ergonomic considerations in the design allow for comfortable use and can easily be operated by either male or female. The parameters under investigation were threshing efficiency, cleaning efficiency, tool grain loss and grain breakage. The power is produced through human operated pedal mechanism.

**Key Words:** Bearing, threshing, efficiency, pedal mechanism, Gear train, Vacuum pump, dynamo with Br TMPGket-6V3W, Kinematic linkages.

## INTRODUCTION

In engineering, many processes are required and different parts required different processes. But the properties of materials and other things change with Richness of a country and its wealth status is always judges or know on compositions (steel) in proper conditions, etc. India has a very large population. By other countries like Japan, Germany and USA pioneers in steel making. Emprises of the bicycle frame mounted on a stationary base frame and the pedal mechanism is coupled to the shaft of the thresher. Earlier, India was flourishing in trade and commerce. But the entrance of East India Company changed the whole scenario. The British started exploiting the Indian resources. They made their market for finished goods in India. Then came the Industrial revolution and industries started prospering again. Then in 1992, came the law that multi-nationals can come and set up their industries, the whole scenario changed, more stress on quality and accuracy was given than the expectations of the customers.

Project is a mission of creating something new, which is innovative i.e. manufacturing of a new products.

## 1.1 Construction and working

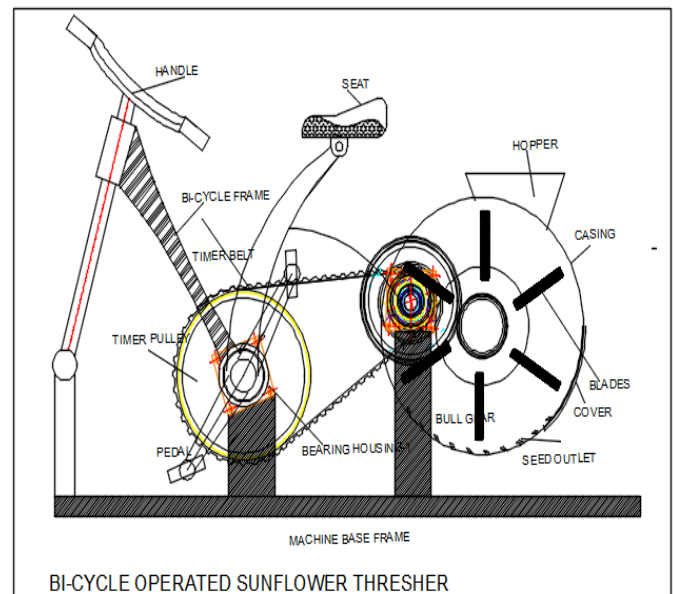

**Fig[1] Pedal operated multi-crop thresher**

The bi-cycle operated thresher comprises of the bicycle frame mounted on a stationary base frame and the pedal mechanism is coupled to the shaft of the thresher mechanism through a gear pair. The spur gear large gear is mounted on the shaft carrying the freewheel sprocket where as the pinion is mounted on the thresher shaft, hence rotation of the pedal at slow speed results in fast first write and rotation of to thresher shaft. The blades strike at a high speed and force against the hemp of the sunflower there by separating the seeds from the hemp and these seeds fall down from the seed outlet.

## Design Methodology

In our attempt, to design as special purpose machine. We have adopted a very careful approach the total design work has been divided into 2 parts mainly

1. System design
2. Mechanical design

System design mainly concerns with the various physical constraints and ergonomics space requirements, arrangement of various components on the main frame of machine no. of controls position of these controls ease of maintenance scope of further improvements ; weight of machine from ground etc .In mechanical design the components in two categories. For design parts details design is done and dimensions thus obtained are compared to next highest dimension which are readily available in market this simplifies the assembly as well as post production servicing work. The various tolerance on work are specified in the manufacturing drawings the process charts are prepared and passed on to the manufacturing stage.

### System design

#### 1. System selection based on physical constraints:-

While selecting any m/c it must be checked whether it is going to be used in large scale or small scale industry In our care it is to be used in small scale industry So space is a major constrain .The system is to be very compact it can be adjusted to corner of a room.

#### 2. Arrangement of various component :-

Keeping into view the space restriction the components should be laid such that their easy removal or servicing is possible moreover components can be easily seen and none should be hidden every possible space is utilized in component arrangement

#### 3. Components of system:-

As already started system should be compact enough so that it can be accommodated at a corner of a room.

All the moving parts should be well closed and compact A compact system gives a better look and structure.

#### 4. Man-machine Interaction:-

The friendliness of machine with the operation is an important criterion of design. It is application of anatomical.

E.g. 1. Design of machine height

2. Energy expenditure in hand operation

#### 5. Servicing facility :-

The layout of components should be such that easy servicing is possible especially those components which required frequent servicing can be easily disassembled.

#### 6. Scope of future improvement:-

Arrangement should be provided to expand the scope of work in future such as to convert the m/c motor operated this system can be easy configured to required one.

#### 7. Height of machine from ground:-

Fore ease and comfort of operator the height of m/c should be properly decided so that he may not get tired during operation .The m/c should be slightly higher than that the level also enough clearance be provided from ground for cleaning purpose.

#### 8. Weight of machine:-

The total wt of m/c depends upon the selection of material components as well as dimension of components. A higher weighted m/c is difficult for transportation

### Mechanical design

Mechanical design phase is very important from the view of designer .as whole success of the project depends on the correct deign analysis of the problem. Many preliminary alternatives are eliminated during this phase. Designer should have adequate knowledge above physical properties of material, loads stresses, deformation, failure. Theories and wear analysis , He should identify the external and internal forces acting on the machine parts.

These forces may be classified as ;

- a) Dead weight forces
- b) Friction forces
- c) Inertia forces
- d) Centrifugal forces
- e) Forces generated during power transmission.

Designer should estimate these forces very accurately by using design equations .If he does not have sufficient information to estimate them he should make certain practical assumptions based on similar conditions which will almost satisfy the functional needs. Assumptions must always be on the safer side. In mechanical design, the components are listed down & stored on the basis of their procurement in two categories

- Design parts
- Parts to be purchased

For design parts a detailed design is done & designation thus obtain are compared to the next highest dimension which is ready available in market. This simplification the assembly as well as post production service work. The various tolerance on the work are specified. The process charts are prepared & passed on to the work are specified. The parts to be purchased directly are selected from various catalogue

### Design of the driver pedal

Cross section of link may be determined by considering lever in bending ;

The linkage has an section of (25 x 10 )mm

Let; t= thickness of link

B= width of link

m=Modules

P=Maximum Effort applied by hand

Z=No.of teeth

Bending moment; Section modules;  $Z= 1/6 t b^2$

$$F_b = m/z = PL/(1/6)t B^2$$

### Design of pedal Shaft

According to ASME code permissible values of shear stress may be calculated form various relation.

$$f_{s \max} = 0.3 f_{yt}$$

Torque transmitting capacity of clutch

$$M_t = F_t \times Z \times R$$

Where,  $F_t$  =Tangential force,Kgf,

Z = Number of rollers,

$M_t$  = Transmitted Torque Kgf.cm

### CONCLUSION

On the basis of literature survey, we are understand that to provide an evaluation of threshing machine. This paper provides different mechanism for harvesting, cultivation as well as ,varies method to find out strength, and test are find with help of literature view.

Some information can be sort out by with the hop of literature view.

### REFERENCES

- [1] Machine Design : R. S. Khurmi.
- [2] Mechanisms and linkages : Chironis.
- [3] Design of machine elements : V. B. Bhandari.
- [4] P. Narasimhulu and N. Jaya Krishna "Modeling and Fabrication of Pedal Operated Multi Crop Cutter."
- [5] Dr.U.V. Kongre, Lokesh Shahare, Aakash Mutkule, Akshay Komawar "Fabrication of Multicrop Cutter."
- [6] R. K. Naik, S.Patel, A. K. Vermaand, A. K. Shrivastavaby "Effect of crop and machine parameters on performance of paddy thresher".