

# DEVELOPMENT OF ENERGY EFFICIENCY OF ELECTRICAL APPLIANCES

S. Ramvel Rajan<sup>1</sup>, A. Arun Pradeep<sup>2</sup>, M.Sathish Kumar<sup>3</sup>, M. Pravin<sup>4</sup>, A.G. Akash<sup>5</sup>,

Dr. D. Prince Winston<sup>6</sup>

<sup>1,2,3,4,5</sup> UG Scholars, Dept. of EEE, Kamaraj College of Engineering & Technology, Madurai, Tamil Nadu, India.

<sup>6</sup> Associate Professor, Dept. of EEE, Kamaraj College of Engineering & Technology, Madurai, Tamil Nadu, India.

\*\*\*

**Abstract** - The energy demand in the world has been fueled by petroleum-based sources. With their quantities drastically decreasing, it is time to look towards renewable energy resources. But the efficiency of the load system is the crucial factor at defining the quality power consumption. 25% of the total electrical power generated is not effectively utilized. Researches have been keen at developing integrated systems capable of effectively utilizing most of the power available at the load system. Power electronics has a major part in this aspect. This work focuses on experimental consideration of improving efficient consumption in street lighting and water pumping in domestic arena. We have employed LDR based sensor which keeps track of possible intrusions until then the lighting system is tripped thus consuming power only when the system is required to be switched on. Similarly, we have employed ultrasonic sensors to keep track of water level. The water level is referenced at the control system. Once the level of water decreases or increases, the main control is tripped off and thus, the efficient working of the motor is improved.

**Key Words:** NodeMCU, water level monitoring, street light controlling, LDR

## 1. INTRODUCTION

After 50 years our country faces lot of problems based on electricity and water. Because, scarcity of electricity and water is tremendously increasing day by day. The root of this problem is wastage of electricity domestic water. In our day today, life we waste electricity during much electrical application. In our domestic usage during the water pumped to the tank with the help of motor we waste lot of water and electricity during overflow. Nearly 10 % to 15% of water wasted based on overflow in the total amount of water in the tank. Similarly, lot of electricity is wasted in street light system in domestic and commercial areas. These two problems lead to dead line of our country.

Our project gives the solution for this problem. Our project uses ultrasonic sensors to monitor the water level in the water tank, then compute the results with the help of cloud computing and automatically turn ON and OFF the motor based on the water level. This is very much useful to monitor the water level in anywhere at any time with the help of our mobile phone. The monitoring of water level is very much useful in the industries such as chemical, dairy, power plants also. Similarly, we used LDR sensor-based sensor which

keeps track of possible intrusions until then the lighting system is tripped thus consuming power only when the system is required to be switched on. Hence our project gives the best solution to save the water and electricity. This will create a great impact on saving of water and electricity.

## 2. BLOCK DIAGRAM FOR WATER LEVEL MONITORING

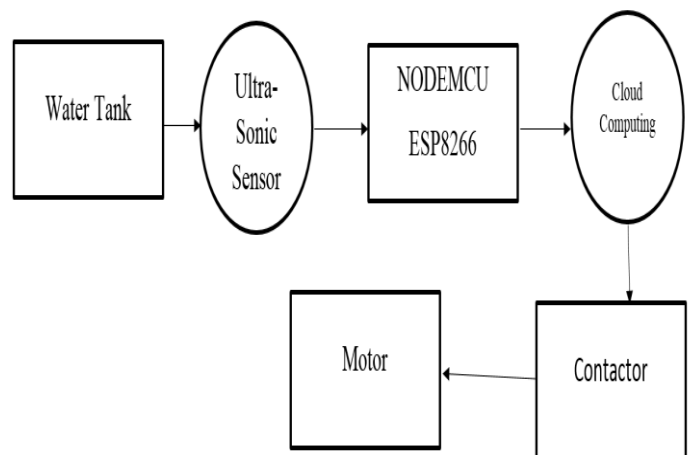

## 3. BLOCK DIAGRAM FOR STREET LIGHT CONTROLLING:

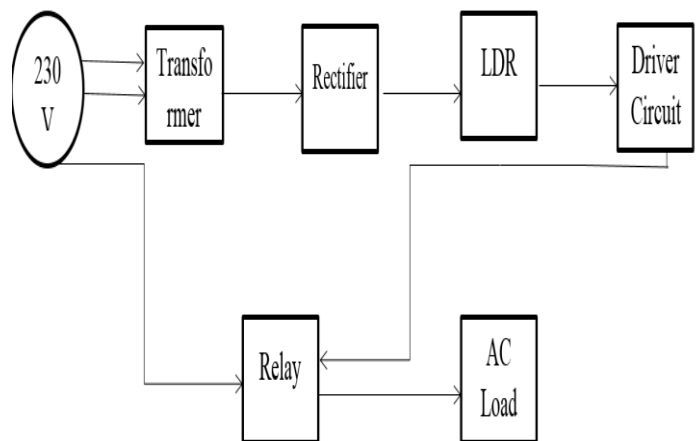

## 4. METHODOLOGY

### 4.1 Water Level Monitoring

To monitor the water level with the help of sensor called ultrasonic sensor and a controller called NODEMCU. The ultrasonic sensor has a transmitter and a receiver. The transmitter is used to transmit the ultrasonic waves to hit the object and the receiver receives the signal from the object this will help to monitor the level of the object. This principle is used in the water tank to monitor the level of water. Every water tank has the supportive pipe line arrangement to release the air flow. In that pipe line when the water level increases in the tank the water level is also increases in the pipe line also. Hence in this arrangement we place an ultrasonic sensor in the top of the pipe line and insert a ball like arrangement inside this ball like arrangement is plays a major role like the object. Because this ball like arrangement receives and transmits the ultrasonic waves. Hence the ultrasonic sensor collects the data from the pipe line.

The collection of data from the ultrasonic sensor is given to the cloud computing with the help of controller called NODEMCU. The NODEMCU is a Wi-Fi module controller. It is used to collect the data base from the ultrasonic sensor and given to cloud computing. The NODEMCU needs 5V power supply the power supply is given from the solar PV panel instead of wiring because wiring have lot of power loss during supply. The solar PV panel is used because it is a renewable energy source. This arrangement composed of panel, rechargeable 6V battery and charger controller placed on the top of the sensor arrangement in the pipe.

The motor tripping is also programmed in the controller. If the water level is below 10% the motor is automatically turned ON and if the water level is above 90% the motor is automatically turned OFF. Suppose the ground water level is very low then the motor is running without water this will cause a problem in motor. Hence to solve this problem our programmer also has the programming to trip the motor. If the motor is running for a particular time then particular level of water increases if not increases the motor will be automatically OFF. This will increase the lifetime of the motor.

This is the working methodology of our project. The cost of the project is very low. Hence each and every home can install our project for saving the water and to safeguard from the water scarcity problems in the future.

### 4.2 Result

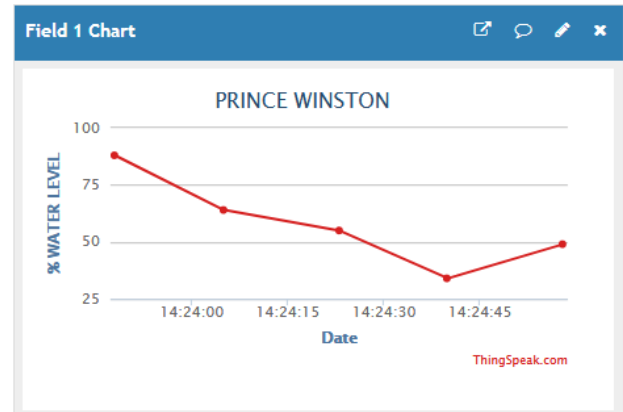

This is the cloud computing graphical representation of our project. In this graph Y-axis represents percentage of water and X-axis represents time.

### 4.3 Automatic Street Light Control

Our motive is to control the lamp automatically with the help of sensor called LDR (Light Depending Resistor). The LDR require a DC supply hence the 230V AC supply is Step down into 6V AC with the help of step-down transformer. Fatherly the 6V AC supply is directly converted into DC supply with the Bridge Rectifier. The LDR needs 5V DC supply is given from the bridge rectifier circuit. The LDR working depending on the resistance value and the photo conductivity. When the photons fall on the surface of the LDR then the resistance will become less hence the conductivity becomes much more than the movement of electrons takes place hence it controls the load. The output from the LDR is 5V and 0.4 mA. This is not sufficient for relay. Therefore, the driver circuit is used for the current injection. The driver circuit consist of resistors and transistors. This is used to drive the 5V relay. The NO/NC (Normally Open / Normally Closed) relay controls the load.

Hence the load is controlled with LDR automatically respect to the light intensity and the conductivity.

## 5. OUTCOMES OF OUR PROJECT

The following are the outcomes of our project,

- (1) Wastage of water is to be minimized.
- (2) Monitor water level in anywhere at any places.
- (3) Automatic motor tripping based on the water level.
- (4) Saving of time while motor ON and OFF.
- (5) Automatically control the Lamps.

## 6. CONCLUSION

The water level is monitored with the help of ultrasonic sensor and NODEMCU and also tripping the motor based on the water level in the water tank and the light loads are controlled with the help of LDR automatically.

## ACKNOWLEDGEMENT

We would like to thank our guide Dr. D. Prince Winston, Professor of our department for guiding us to complete our project.

## REFERENCES

- [1] Water Level Monitoring System Using Iot Priya, Sailusha Chekuri International Research Journal of Engineering and Technology (IRJET) e-ISSN: 2395-0056 Volume: 04 Issue: 12 | Dec-2017.
- [2] Singh, O. Jeba, D. Prince Winston, B. Chitti Babu, S. Kalyani, B. Praveen, M. Saravanan Kumar, and S. Cynthia Christabel. "Robust detection of real-time power quality disturbances under noisy condition using FTDD." *AUTOMATIKA* 60, no. 1 (2019): 11-18.
- [3] Meenakshi Sundaram, B., Manikandan, B.V., Praveen Kumar, B. et al. *J. Electr. Eng. Technol.* (2019) 14: 733. <https://doi.org/10.1007/s42835-018-00075-9>
- [4] Praveen, S., and D. Prince Winston. "Protection and performance improvement of a photovoltaic power system." *Advances in Electronic and Electric Engineering* 4.1 (2014): 41-48.
- [5] Pounraj, P., et al. "A continuous health monitoring system for photovoltaic array using arduino microcontroller." *Circuits and Systems* 7.11 (2016): 3494.
- [6] Christabel, S. Cynthia, A. Srinivasan, and D. Prince Winston. "Couple matching best generation algorithm for partially shaded photovoltaic systems." *Journal of Electrical Engineering* 16.3 (2016): 382-391.
- [7] Christabel, S. Cynthia, et al. "Reconfiguration solution for extracting maximum power in the aged solar PV systems." *Journal of Electrical Engineering* 16.3 (2016): 440-446.
- [8] Marimuthu, P., and B. Praveen Kumar. "Reconfiguration of 25 kW solar PV power plant." *International Journal Of Engineering And Computer Science* 6.6 (2017).
- [9] Kumar, B. Praveen, et al. "Implementation of a switched PV technique for rooftop 2 kW solar PV to enhance power during unavoidable partial shading conditions." *Journal of Power Electronics* 17.6 (2017): 1600-1610.
- [10] Shitharth, S., and D. Prince Winston. "A novel IDS technique to detect DDoS and sniffers in smart grid." *Futuristic Trends in Research and Innovation for Social Welfare (Startup Conclave), World Conference on. IEEE, 2016.*
- [11] Winston, D. Prince, and M. Saravanan. "Single parameter fault identification technique for DC motor through wavelet analysis and fuzzy logic." *Journal of Electrical Engineering and Technology* 8.5 (2013): 1049-1055.
- [12] Mary, S. Merlin Joys, S. Rajesh Babu, and D. Prince Winston. "Fuzzy logic based control of a grid connected hybrid renewable energy sources." *Int. J. Adv. Res. Electr. Electron. Instrum. Eng* 3.4 (2014): 1043-1048.
- [13] Christabel, S. Cynthia, M. Annalakshmi, and Mr D. Prince Winston. "Facial feature extraction based on local color and texture for face recognition using neural network." *International Journal of Science and Engineering Applications* 2.4 (2013): 78-82.
- [14] Shitharth, S., and D. Prince Winston. "A Comparative Analysis between Two Countermeasure Techniques to Detect DDoS with Sniffers in a SCADA Network." *Procedia Technology* 21 (2015): 179-186.
- [15] Gurukarthik Babu, B., et al. "Study on characterization and physicochemical properties of new natural fiber from *Phaseolus vulgaris*." *Journal of Natural Fibers* (2018): 1-8.
- [16] Manikandan, P., and V. Neviya. "Lieutenant. J. Ganesan, D. Prince Winston "Experimental Analysis of Total Harmonic Distortion by Applying Various PWM Techniques on Three Phase Squirrel Cage Motor"." *International Journal of Research in Computer Applications and Robotics* 2.2 (2014): 82-92.
- [17] Singh, O. Jeba, and D. Prince Winston. "A Survey on Classification of Power Quality Disturbances in a Power System." *Journal of Engineering Research and Applications* 4.8 (2014): 80-84.
- [18] Sakthivel, K., and D. Prince Winston. "Application of Optimization Techniques In Smart Grids." *International Journal of Science, Engineering and Technology Research (IJSETR)* 3 (2014): 32-36.
- [19] Winston, D. Prince, M. Saravanan, and S. Arockia Edwin Xavier. "Neural Network Based New Energy Conservation Scheme for Three Phase Induction Motor Operating under Varying Load Torques." *Process Automation, Control and Computing (PACC), 2011 International Conference on. IEEE, 2011.*
- [20] Winston, D. Prince, and M. Saravanan. "Novel Energy Conservation Scheme for Three Phase Induction Motor Drives Employed in Constant Speed Applications." *Przegląd Elektrotechniczny* 88.11a (2012): 243-247.
- [21] Winston, D. Prince, and M. Saravanan. "A Modified Energy Conservation Circuit for Chopper fed DC Motor Drive." *Przegląd Elektrotechniczny* 88.12a (2012): 295-296.
- [22] Prince Winston, D, Praveen Kumar, B, Cynthia Christabel, S, Ali Chamkha, J & Ravishankar Sathyamurthy 2018, 'Maximum power extraction in solar renewable power system - a bypass diode scanning approach', *Computers and Electrical Engineering*, vol. 70, pp. 122-136.
- [23] Praveen Kumar, B, Prince Winston, D, Pounraj, P, Muthu Manokar, A, Ravishankar Sathyamurthy & Kabeel, A.E 2018, 'Experimental investigation on hybrid PV/T active solar still with effective heating and cover cooling method', *Desalination*, vol. 435, pp. 140-151.
- [24] Shitharth, S. "An enhanced optimization based algorithm for intrusion detection in SCADA network." *Computers & Security* 70 (2017): 16-26.
- [25] Manokar, A. Muthu, et al. "Comparative study of an inclined solar panel basin solar still in passive and active mode." *Solar Energy* 169 (2018): 206-216.

- [26] Manokar, A. Muthu, et al. "Integrated PV/T solar still-A mini-review." *Desalination* 435 (2018): 259-267.
- [27] Manokar, A. Muthu, et al. "Sustainable fresh water and power production by integrating PV panel in inclined solar still." *Journal of Cleaner Production* 172 (2018): 2711-2719.
- [28] Pounraj, P., et al. "Experimental investigation on Peltier based hybrid PV/T active solar still for enhancing the overall performance." *Energy Conversion and Management* 168 (2018): 371-381.
- [29] Kabeel, A. E., et al. "A Review on Different Design Modifications Employed in Inclined Solar Still for Enhancing the Productivity." *Journal of Solar Energy Engineering* 141.3 (2019): 031007.
- [30] Manokar, A. Muthu, et al. "Experimental investigation on pyramid solar still in passive and active mode." *Heat and Mass Transfer* (2018): 1-14.
- [31] Manokar, A. Muthu, and D. Prince Winston. "Experimental analysis of single basin single slope finned acrylic solar still." *Materials Today: Proceedings* 4.8 (2017): 7234-7239.