

## Automatic Fire Extinguisher system

Saurabh Sarang<sup>1</sup>, Sanket Kahane<sup>2</sup>, Manoj Matsagar<sup>3</sup>, Vaibhav Kokane<sup>4</sup>, Amol varade<sup>5</sup>

<sup>1234</sup>Student, Dept. of Electrical Engineering, AVCOE Sangamner, Maharashtra, India.

<sup>5</sup>Assistant professor, AVCOE Sangamner, Maharashtra, India.

\*\*\*

**1. Abstract –Protecting and preserving** an institution's buildings, collections, operations and occupants. Items destroyed by fire, however, are gone forever. An uncontrolled fire can obliterate an entire room's contents within a few minutes and completely burn out a building in a couple hours. The first step toward halting a fire is to properly identify the incident, raise the occupant alarm, and then notify emergency response professionals. This is often the **function of the Automatic fire extinguisher system**. Several system types and options are available, depending on the specific characteristics of the protected space. Fire protection experts generally agree that automatic sprinklers represent one of the single, most significant aspects of a fire management program. Properly designed, installed, and maintained, these systems can overcome deficiencies in risk management, building construction, and emergency response. They may also provide enhanced flexibility of building design and increase the overall level of fire safety. The following text presents an overview of fire detection, alarm and sprinkler systems working.

### 2. INTRODUCTION:

Recent and earlier fire incidents have clearly demonstrated some of the major shortcomings in our firefighting capabilities along the length and breadth of the country. The recent fire incident in a hospital in India has added another dangerous possibility and dimensions to fire accident. We need to have a serious look at the capabilities of our fire services in this context. If the teletherapy machine in the hospital had been damaged, the incident would have assumed a completely different tone and escalated into an even worse tragedy. The Mayapuri incident in our country is

a very recent example of what can happen if a radiological device gets damaged. We need to examine whether our fire services have the capability to respond in a fire incident when radiological equipment has got damaged. Are the fire services trained and equipped to respond or even capable to contain and restrict the dangers till other experts arrive? There is more than an urgent need to ensure that the fire services are well equipped and trained to respond to all possible vulnerabilities resulting out of fire accidents.

Fire extinguishers, in one form or another, have probably postdated fire by only a short time. The more practical and unitized extinguisher now commonplace began as a pressurized vessel that spewed forth water, and later, a combination of liquid elements. The older extinguishers comprised cylinders containing a solution of baking soda (sodium bicarbonate) and water. Inside, a vessel of sulfuric acid was positioned at the top of the body. This design had to be turned upside down to be activated, so that the acid spilled into the sodium bicarbonate solution and reacted chemically to form enough carbon dioxide to pressurize the body cylinder and drive out the water through a delivery pipe. This volatile device was improved by placing the acid in a glass bottle, designed to be broken by a plunger set on the top of the cylinder body or by a hammer striking a ring contraption on the side to release the acid. Cumbersome and sometimes ineffective, this design also required improvement.[1]

advantages of fire system mist has been received considerable attention for fire suppression in recent years due to many advantages, such as high fire extinguishing effectiveness, less water consumption, no pollution to environment, safety to protected objects etc. Considerable numbers of studies and applications of water mist system in normal altitude areas have been carried out widely.[2]

Fire protection of historical buildings in high altitude areas with water mist had also been performed recently. We studied the applicability and design optimization of water mist system aiming many application. Comparison fire suppression effectiveness of water mist with conventional fire suppression technologies, known as carbon dioxide extinguisher and sprinkler system. Studies had also been performed on spray characterization with the consideration of ambient pressure effects. We studied the effects of ambient pressure on spray of an atomization nozzle, where the ambient pressure was changed.[3]

The effects of working pressure and ambient density on spray characteristics.[4]

Fire brings great harm to the country's economic and social stability, the current fire detection and alarm system use the two bus for connecting Smoke temperature composite fire detector and central console. It has anti-interference, high reliability, etc., It has been widely used in society and played an important role in Socio-economic, national security. But it is high cost, design, construction and maintenance is complex. So people invented the wireless fire detection and alarm system.[5]

Recently, wireless fire detection and alarm system has been rapid development. Has Emerge in the wireless temperature, smoke, smoke temperature composite fire detection and alarm system.[6]

Sprinkler system is a kind of fixed extinguishing system and has been widely used all over the world. Many references have carried on deep discussions and propose their own views on the water distribution characteristics of sprinkler in sprinkler systems. According to reference, sprinkling density is uniformly distributed in the sprinkling effective coverage area. [7]

Sprinkling density is a major parameter for fire controlling capability of the sprinkler system. Sprinkling distribution characteristics of sprinkler are studied and analyzed from an experimental viewpoint.[8]

The NFPA established the Technical Committee on Fire Pumps in 1899 to create a uniform set of guidelines to govern the proper installation of fire pumps. The 1993 edition of NFPA 20 included "...significant revisions to the arrangement of power supply to electric-driven fire pumps. These clarifications were intended to provide the necessary requirements to make the system as reliable as possible...".[9]

effectiveness of a fire-pump system designed and installed per NFPA 20 to provide protection for a building or facility. A basic premise governing the requirements found in NFPA 20 is that single-fault failures that could result in total system failure must be minimized. The preface to Pumps for Fire Protection Systems.[10]

**3.Need:**

The need of this project is to increase the safety of emergency responders and building occupants by providing information about how firefighters typically interact with building features and fire protection systems during fires and similar emergencies. By better understanding the needs of the fire service, designers and code officials can work together to streamline fire service emergency operations within the built environment.

The faster the fire service can respond, enter, locate the emergency incident, and safely operate in or near a building, the sooner they can usually resolve the incident in a safe manner. This, in turn, will likely increase the safety of building occupants (workers, residents, and visitors), reduce property damage, and limit related indirect losses. Therefore, both building occupants as well as fire service employees will realize the benefits of this document in terms of reasonably safe working conditions as intended by the Occupational Safety and Health Act of 1970.

**4.Block Diagram:**

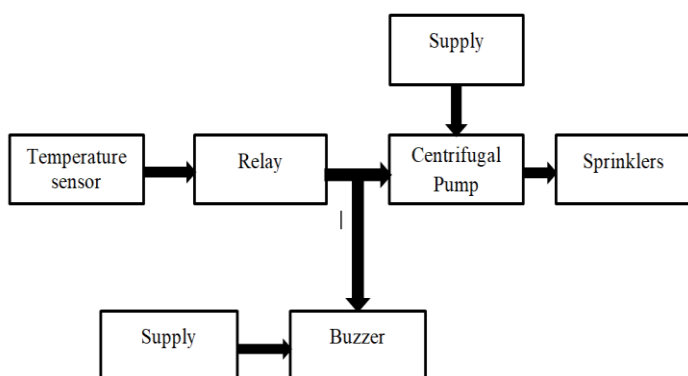

**3. Working**

The working of project is mainly depend on temperature sense by the thermostat. Firstly we have to set temperature on thermostat according to our requirement. For The temperature below the set point

system remain in off condition. At the moment when temperature is goes beyond the set temperature the system is turn on and sprinklers star spraying the water or extinguisher medium.

The temperature is sense by the temperature sensing device (thermostat).then this signal is go through relay unit. Relay is act as the controlling switch to turn on and off the centrifugal pump and alarm unit ,then by using centrifugal pump extinguisher medium is passes through pipe with pressure and then it spread or through on fire source.

**5.Actul Circuit Diagram:**

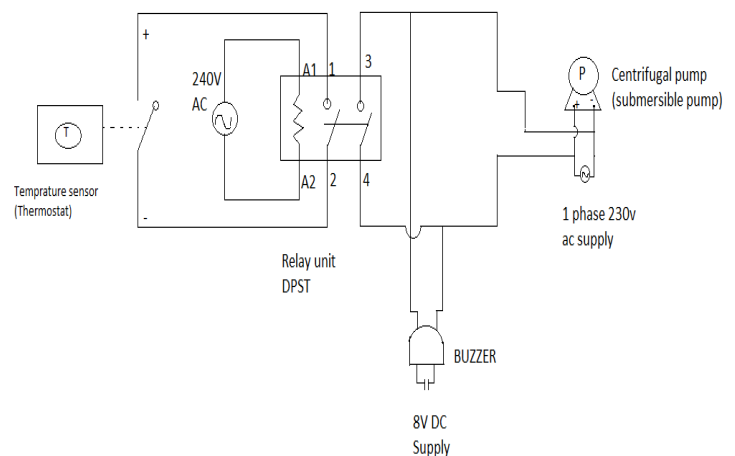

**6.Comparision with existing system:**

Sr/no.	Automatic fire extinguisher	Traditional extinguisher
1.	More effective	Less effective
2.	Automatic system	Manual system
3.	Less operation time	More time for operation
4.	Automatic system so no need of man power	Required man power
5.	Required less fire extinguisher medium for same intensity of fire	Required more fire extinguisher medium for same intensity

## 7. CONCLUSIONS

Automatic fire extinguishing system with nozzle has better reliability, portability, cost-effectiveness, a very simple design, good serviceability and operable at almost all places. Soon most of the manual fire control will be replaced by automatic for their swift action in case of fire and there location at unconventional positions difficult for human interference. The government should persuade construction and manufacturing industries to install such automatic system, which will save both life and property.

## 8. REFERENCES

- [1] David Wagman, powerplant run on Co<sub>2</sub>, June-2018.
- [2] Torgrim Log, Peter Cannon-Brookes, Water mist for fire protection of historic buildings and museums, Museum Management and Curatorship, 14(3), pp. 283-298 (1995)
- [3] Liao Guangxuan, Huang Xin, Cong Beihua, Qin Jun, Liu Jianghong, Wang Xishi, Progress in water mist fire suppression technology, Journal of University of Science and Technology of China; 36(1), pp. 9-19.(2006)
- [4] Wang Xishi, Liao Guangxuan, Qin Jun and Fan Weicheng, Experimental study on effectiveness of extinction of a pool fire with water mist, Journal of Fire Sciences. 20(4), pp. 279-295. (2002)
- [5] Wu Longbiao, Fang Jun, Xie Qiyuan. Fire detection and information processing[M]. Beijing: Chemical Industry Press, 2006, 264-265(in Chinese)
- [6] Chen nan. Design of Fire Detection and Control Systems for Intelligent Buildings[M]. Beijing: Tsinghua University Press, 2001, 7: 19-60(in Chinese)

- [7] Deng Ke-yang: The numerical simulation of the spatial distribution of water spray intensity for ZST-15 sprinklers, journal of China water & wastewater, supplement of Vol.33 (2007) (In Chinese)
- [8] XU Xiao-ling, YAO Bin, WANG Han-jie and LI Juan: Water density probability distribution and fire control capability of sprinkler system, journal of FIRE SAFETY SCIENCE, Vol.18, No.3(2009) (In Chinese)
- [9] Standard for the Installation of Stationary Pumps for Fire Protection, NFPA Standard 20, 2007.
- [10] K. E. Isman and M. T. Puchovsky, Pumps for Fire Protection Systems. Quincy, MA: NFPA, 2002.

## BIOGRAPHIES

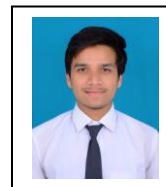

Mr. Sanket Dnyaneshwar Kahane.  
Appearig in BE Electrical from AVCOE, Sangamner, Maharashtra, India.



Mr. Saurabh Suresh Sarang.  
Appearig in BE Electrical from AVCOE, Sangamner, Maharashtra, India.



Mr. Manoj Shivaji Matsagar.  
Appearig in BE Electrical from AVCOE, Sangamner, Maharashtra, India.



Mr. Vaibhav Dinkar Kokane.  
Appearig in BE Electrical from AVCOE, Sangamner, Maharashtra, India.



Mr. Amol Sopan Varade.  
Currently working as assistant professor in AVCOE, Sangamner, Affiliated to Pune university, Completed PG in Electrical Machine And Drives. And Research Area is electrical Drives, Solar Design, Safety Measures from electrical.