

# Implementation of Smart Secure System in Motorbike using Bluetooth Connectivity

S.Srithar<sup>1</sup>, V.S.Venkata Suvathe<sup>2</sup>, S.Vijay Pandi<sup>3</sup>, M.Mounisha<sup>4</sup>

<sup>1</sup>Assistant Professor, Dept of Computer Science and Engineering, RVS College Engineering and Technology, Tamil Nadu, India

<sup>2,3,4</sup>UG Student, Dept of Computer Science and Engineering, RVS College of Engineering and Technology, Tamil Nadu, India

\*\*\*

**Abstract** - Motorbikes are mostly preferred than cars, India is one among the popular countries that have a large craze for two wheelers. Over last few decades accidents are prolonged in recent times, one of the major reasons is riding a vehicle without a helmet and the other is drunk and drive. To the extent of overhead these issues, an enforcement of smart helmet was put forward using a microcontroller to track the area of mishap using GSM and GPRS is to inform responsible persons at the earliest about the accident so they can take action to save the life of the injured persons. In this paper, we profound the substitution of normal key to Passive Switch Key using RFID, need of wearing a helmet and identifying liquor utilization from turning on of the motorbike upheld by HELMET-ALCHO LOCK detecting function. To distinguish capacity and controlling the speed by backing off when speed breaker is perceived, which is imparted through Bluetooth.

**Key Words:** Smart Helmet, RFID module, Bluetooth, Arduino, MQ-6, IR.

## 1. INTRODUCTION

Cruisers and bicycles structure an essential piece of customized transportation in India. Be that as it may sadly, it likewise includes countless mishaps and consequent loss of lives. Consistently, around 300,000 adolescents go to the crisis division in light of motorcycle wounds, and no less than 10,000 youngsters have wounds that require a couple of days in the emergency clinic. Insights state, cruiser passing's represented 15% of all engine vehicle crash in recent times since 2017, and were more than twofold the quantity of motorcyclist passing in 2017 mid. Through on ONEISS overview led by the Department of Health, it was discovered that 90% of the bikes rider killed in mishaps were not wearing a protective cap at the reason of effect. These, alongside intoxicated driving are a vital reason of mishaps. We mean to relieve these issues and subsequently the related losses by guaranteeing that the rider will wear the protective cap all the time amid his/her ride, in this manner guaranteeing security. The protective ca can comprehend if the individual is wearing the cap, utilizing the weight sensors, fitted inside the cushioning froth.

Major reason for occurrence of accidents mainly absence of wearing helmet, drunk and drive where the use of smart helmet integrated with microcontroller using GSM and GPRS for informing the responsible persons about the accident for required actions to take place[1]. This intimation was given only at the time of accident by attaching various sensors on helmet like vibration sensors, tilt sensor used to recognize the event of occurrence and intimation is given via the GSM and GPRS to the responsible person about the accident. But this system may fails when unable to locate the accident occurrence, also if the rider fails to wear the helmet while riding. Also we use Bluetooth connectivity for receiving notification in smart phone to monitoring the vehicle and temperature sensor and automatic speed controller technique is used to prevent vehicle's engine from seizing and indicating speed breaker respectively.

## 2. RELATED WORKS

In the literature, we found several smart helmet systems with several methodologies and proposed arrangements.

Prashant Ahuja, Ketan Bhavsar [1] has proposed a perspective of smart helmet with sensors inserted on it for detecting accident and location tracking. They have embedded multiple sensors on the helmet for detecting accidents. The violation on helmet occurs due to vibration and horizontal tilting position which is placed on the helmet and then location is tracked using GSM and GPRS so that communication is send to responsible person.

Mohammed Khaja Areebuddin Aasif [2] has proposed the efficiency of Bluetooth which connects the owner of the bike through mobile phone. The use of Bluetooth for short range to ensure entire control of bike which can prevent accident in many ways.

C.J.Behr et al [3] has used this smart helmet for the mines industries keeping focus on breathing. The exhale air quality detects the amount of hazardous gases like C<sub>2</sub>H<sub>5</sub>OH and detects the helmet put on using shelf IR.

Mohammed Imaduddin [4] has developed the use of RFID (radio frequency identification) technique for engine to

release its lock reads whether the code present in tags chip and reader are same for the ignition of the engine.

Nina Korlina Madzhi[5] has proposed automatic speed control in bike using ultrasonic sensor with DC motor for monitoring the speed and also controls the speed when obstacle of particular height which is above the height of road.

### 3. TRADITIONAL PROPOSED SYSTEM

We use a method as a replacement for normal key to Passive Switch Key using RFID, necessity of wearing helmet and detecting alcohol consumption right from turning on of the motorbike enforced by using HELMET - ALCHO LOCK detecting function and controlling the acceleration speed by slowing down when speed breaker is recognized, which are communicated through Bluetooth connectivity. Bluetooth sensor is an interface with the client's cell phone which acts as a communication medium for receival of information.

### 4. PROPOSED SYSTEM

#### 4.1 Passive Switch Key Unit

The Passive Switch Key is used to unlock the vehicle to start the engine for a ride, this acts as a replacement of normal key used in a motorbike. The fundamental objective of using this unit is for securing the vehicle from theft, it comprises of RFID (Radio Frequency Identification) tag. Fig.1 shows the presence of Arduino, Reader Module, Tag, LCD and a buzzer is used. Its workings are as follows electric current of 5 voltages is given to Arduino where the RFID reader module is connected. The RFID tag is inserted with 12digit code which is scanned by the reader module for verification. The buzzer is used to indicate via noise for correct and incorrect tag. Once the buzzer recognized, the noise for correct code is just one beep sound is received and for incorrect code prolong beep sound is used for identification. This information is delivered via Bluetooth. Fig.2 shows the picture of Passive Switch Key Circuitry.

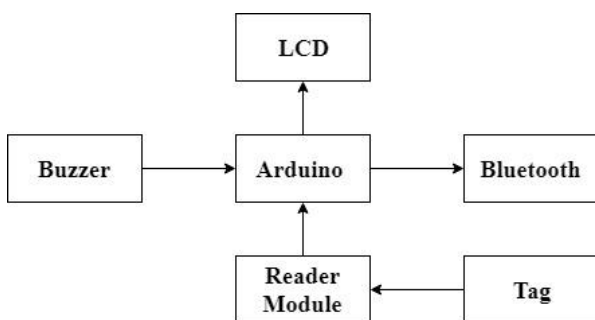

Figure 1: Block Diagram of Passive Switch Key.



Figure 2: Passive Switch Key Circuitry

#### 4.2. HELMET- ALCHO LOCK Detection Function.

The helmet unit comprises of Helmet on detection unit, Alcoho Lock function, Arduino. The above are used for identifying the presence of wearing helmet and distinguish the nonappearance liquor utilization. The HELMET detection unit consist of IR sensor, this sensor senses radiation signals when the heat is sensed by the coil then detects its presence and bounce back signal from the surface and sends the infrared signal to the receiver. This signal is send through Bluetooth and displayed on LCD. Fig.3 depicts the block diagram combined HELMET-ALCHO Lock detection. The ALCHO LOCK function comprises of alcohol sensor (MQ-6) to distinguish the concentration of alcohol while ex-hale of air while breathing from other gases. The MQ-6 sensor can identify liquor concentration from 200 to 1000ppm which has a high affectability with fast response time. The driver circuit is simple all needed is 5V, power with heat coil and add load resistance and the output comes in the form of ADC this is converted and received through Bluetooth and displayed in LCD. Fig.4 shows the HELMET-ALCHO LOCK detection function Circuitry.

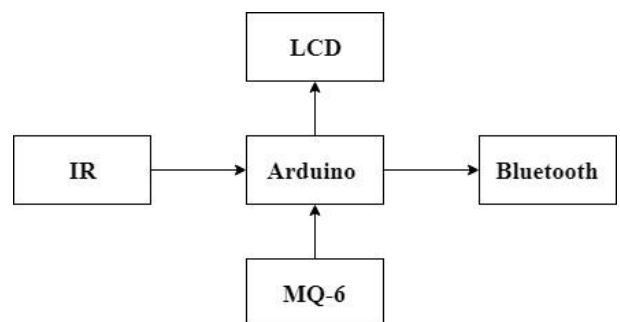
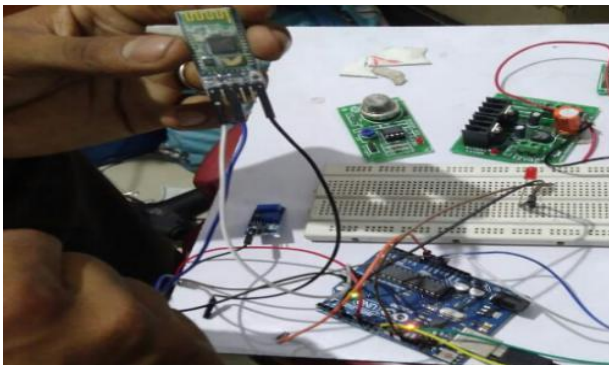

Figure3: Block Diagram of HELMET-ALCHO LOCK detection function



**Figure 4: HELMET-ALCHO LOCK detection function Circuitry**

### 4.3. Controlling Engines acceleration speed to slow Down while detecting Speed Breaker.

The Ultrasonic Sensor is used distinguish capacity distance calculation of controlling the speed when Speed Breaker is detected. The fig.5 shows the presence of Ultrasonic sensor with Arduino, DC Motor, Bluetooth and LCD. This is detected through by placing the is on the motorbike on the front end whenever the height of the road increases higher drastically then it detects and speed is slow down. Thus the device information is send via Bluetooth and also indication is given through LCD display. Fig.6 shows the Controlling acceleration speed to control the speed Circuitry.

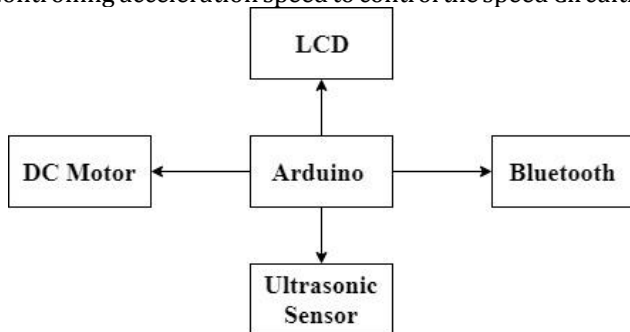

**Figure 5: Block Diagram of Engine from Slow Down while detecting Speed Breaker.**

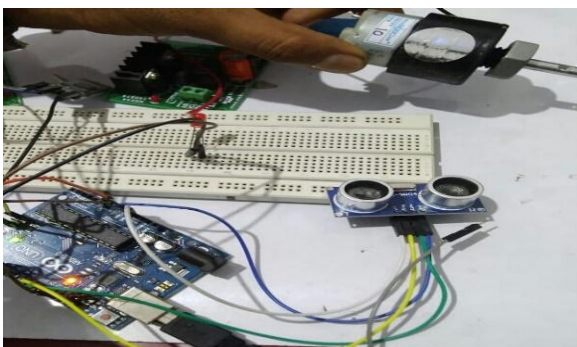

**Figure 6: Controlling acceleration speed to slow down the speed Circuitry.**

## 5. PRINCIPLES OF OPERATION

The proposed system works in sequential order, Firstly the Passive Switch Key is used to unlock the bike using tag which consists of 12digit number. This tag is placed near the reader module; its radiation finds the code in the tag and bounces back to the receiver for detecting the correct or incorrect key. Once the correct key is detected then bike is unlocked else buzzer sound will be given still the bike will be unlocked. Once after the bike is opened with the use of Passive Switch Key then we can go to subsequent step.

Second, so as to see whether the rider is worn helmet and recognize liquor utilization for this we use HELMET-ALCHO LOCK detection function. For Helmet detection Lock is found using IR Sensor which is present in the helmet. The radiation emitted detects helmet presence and bounces back to the receiver and shows the output using Bluetooth connection and LCD display. If the helmet is not detected then engine will not start and prolonged buzzer noise is used to identification.

Third is identifying alcohol consumption, by ex-hale air concentration of the rider we can find out ethanol concentration presence or not. For this MQ-6 Alcohol sensor is used for discovering liquor concentration. The MQ-6 can detect alcohol concentration from 200 to 1000ppm. Once detected then engine acceleration will be lock. Also, either one of the two sub-functions is not done then engine will not start. Unless both condition is satisfied the engine acceleration starts for this we use 30 rpm DC motor which runs continuously.

Fourth, is to control the over speed while crossing the speed breaker sometime may lead to skidding the wheels which leads to accident. For this use same DC motor of 30rpm is slow down the speed. This DC motor gives high quality which runs smoothly from 4V to 12V with wide range of RRM and Torque. Once the deviation from normal height level from the road is detected we use the Ultrasonic sensor for acceleration slow down. Its evaluation for finding distance figuring is done with the reflection of sound waves. The output for the above operations are received through Bluetooth. The Bluetooth signal, that we use HM-10 is a Bluetooth 4.0 low vitality containing IT delivered CC254 or CC2541. It provides reliable and low power consuming which is used for communication medium between the device and the smartphone.

The LCD display is use to executing the operation in prototype, which is a plasma screen with pixel, every pixel is a modest fluorescent light which is turned on or off electrically which receives the output from Arduino.



### 6. SYSTEM FLOW CHART

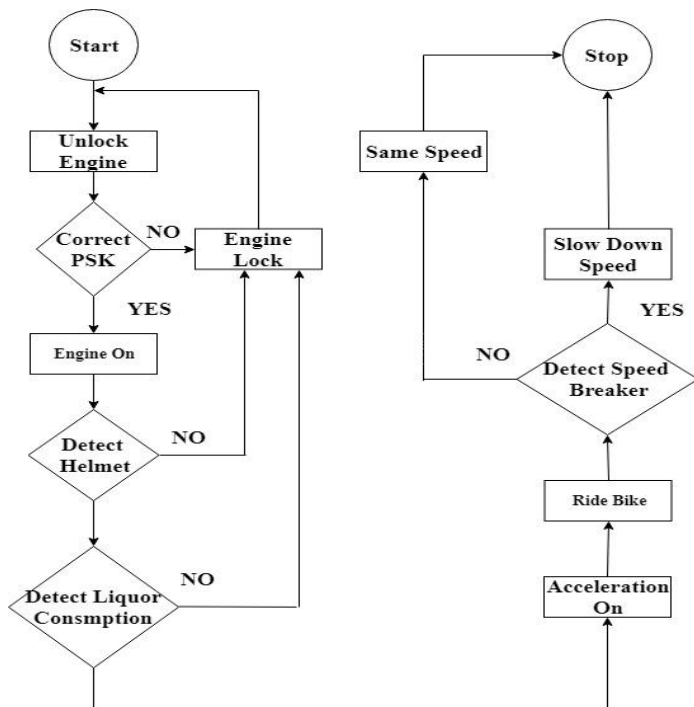

Figure 7: Flow Chart of the System

The flow chart shown fig.7 describes the working principle of how the system work flow is done right from using Passive Switch Key using RFID reader module and tag. Then, we find the presence of wearing helmet or not with the use of this assistance IR sensor and alcohol consumption using MQ-6 alcohol sensor. Only if helmet is worn and liquor not consumed accelerated starts so that the rider can start driving. Next, flow is for checking speed breaker while riding if it is found then by using Ultrasonic sensor we slow down the speed and there after continues its ride as usual. Thus the system flow stops in order to prevent accident and safe driving right from the start of bike turning on.

### 7. HARDWARE REQUIREMENTS

The hardware requirement are shown below:

S.No	COMPONENT	NAME
1.	Microcontroller	Arduino Mega
2.	Alcohol sensor	MQ6
3.	Temperature sensor	Lm 35
4.	Ultrasonic sensor	Ultrasonic HC-SR04
5.	DC Motor	DC motor 40 Volt

6.	RFID Reader	EM-18 Reader Module
7.	RFID Tag	Tag module
8.	Bluetooth	Bluetooth-4.0 HM-10
9.	LCD Display	RG1602A

Table 1: Hardware Requirements

### 8. RESULT

All the components arranged and connected successfully. The circuit is assembled in such a way that the bike will not start unless helmet is worn and liquor is not consumed using HELMET-ALCHO LOCK detection function. Likewise turning on the engine only by using Passive switch key and Slow Down the Speed while detecting Speed Breaker. Thus the experiment is successfully completed and the study was conducted in controlled manner. Fig.8HELMET-ALCHO LOCK Detection Prototype.

This experiment ensures drivers right from starting of the bike to prevent major accident save the lives of lakhs of people.

The future work can be setting an emergency alert switch can used with default numbers during emergency which can be placed on the helmet could be helpful during the emergency situation.

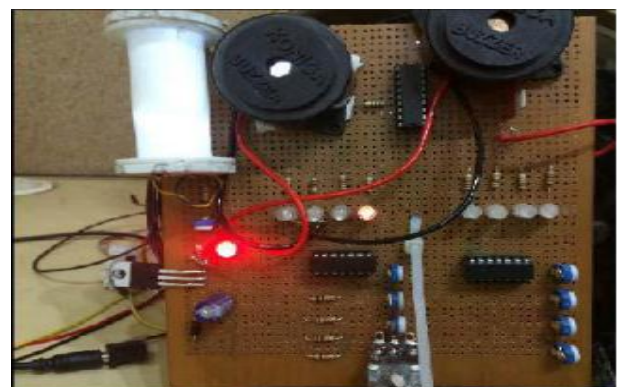
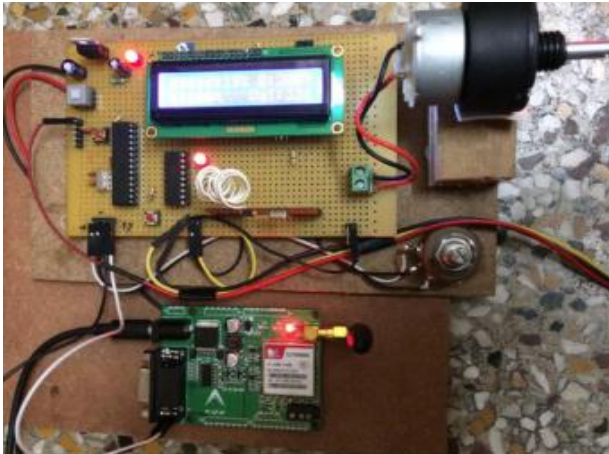

Figure 8: HELMET-ALCHO LOCK Detection Prototype.



**Figure 9: Controlling acceleration speed to slow down the speed unit Prototype**

## 9. CONCLUSION

Keen head protector is a powerful answer for some issues. Wearing helmet and being sober are necessary condition for the bicycle to begin, lessening the potential to overcome of mishaps. Regardless of whether an individual alert or not. This system also acts safety for bike from being theft, slow down speed when speed breaker detected help in engine live time longer.

## REFERENCES

- [1] Prashant Ahuja, Ketan Bhavsar, "Microcontroller based Smart Helmet using GSM and GPRS", second International conference on Trend in Electronics and Information,2018.
- [2] Mohammed Khaja AreebuddinAatif,"Smart helmet Based on IOT Technology" International Journal for Researcher in Applied Science and Engineering Technology,2017
- [3] C. J. Behr; A. Kumar; G. P. Hancke , A smart helmet for air quality and hazardous event detection for the mining industry,IEEE International Conference on Industrial Technology (ICIT),2016.
- [4] Mohammed Immaduddin "Controlling and Calibrating Vehicle-Related Issues",2015.
- [5] S Nagakishore Bhavanam, Vasujadevi M "Automatic Speed Control and Accident Avoidance Of Vehicle using Multi Sensors", Proceedings of International Conference on Innovations in Electronics and Communication Engineering (ICIECE 2014).
- [6] Rashmi Vashisth, Sanchit Gupta, Aditya Jain, "Implementation and Analysis of Smart Helmet"4th IEEE International Conference on Signal Processing, Computing and Control (ISPCC 2017).
- [7] K.Y. Rajput, Gunprabh Chadha, Brij Kanodia,"Smart Helmet", International Research Journal of Engineering and Technology (IRJET),2016.