

## RFID BASED BOOK SHELVING SYSTEM

**AISHWARYASRI V<sup>1</sup>, DIVYA P<sup>2</sup>, MUTHUJANARTHANAN G<sup>3</sup>, GOPALAKRISHNAN T<sup>4</sup>**

<sup>1</sup>B.E Student, Dept. of EIE, Dr.Mahalingam College of Engg and Tech,Tamilnadu, India.

<sup>2</sup>B.E Student, Dept. of EIE, Dr.Mahalingam College of Engg and Tech,Tamilnadu, India.

<sup>3</sup>B.E Student, Dept. of EIE, Dr.Mahalingam College of Engg and Tech,Tamilnadu, India.

<sup>4</sup>Assistant Professor(SS), Dept. of EIE, Dr.Mahalingam College of Engg and Tech,Tamilnadu, India.

\*\*\*

**Abstract** –Radio Frequency Identification and Detection is about the design and implementation of books identifier on the bookshelf. When a book is misplaced in any bookshelf, the system will pop out a message in the computer to alert the librarian of the misplaced book and also buzzer will be alert. The popped out message not only shows the information of misplaced books, but it also shows the details of the book to be placed on that shelf and it has an advantage of sending notification to the students knowing about the issuing and returning of the books.. When the books belonging to that bookshelf are correctly placed, the alert message will not pop out. For ease of demonstration in the prototype, two books were used for testing and a bookshelf was designed to place only two books and one interface system to connect the bookshelf to the computer. To display the alert message, visual basic is designed in the computer to identify the misplacement of books on the bookshelf and to reduce the burden of the librarian.

**Keywords:** Radio Frequency Identification and Detection, Node mcu , Books, Visual Basic, Students mobile.

### 1. INTRODUCTION

RFID is being used for a wide variety of applications ranging from building access control proximity cards to supply chain tracking, toll collection, vehicle parking access control, retail stock management, library books tracking, theft prevention, vehicle immobilizer systems, and railway rolling stock identification and movement tracking. RFID reviews the literature on the use of RFID in library management and service through an innovation decision framework. RFID provides a brief introduction to the RFID technology, current challenges faced by libraries, and how the use of RFID technology can address these challenges. The specifics of RFID technology in different areas of library management and services before examining the potential benefits of RFID, and identifying barriers to its acceptance. RFID proposes a critical success factor framework for RFID implementation based on the publications reviewed and provide guidance for librarians and students to identify whether the books are placed in proper shelves or not with an notification in mobile and visual basics. RFID technology is widely used in libraries and warehouses. [1] Mehrjerdi (2011) reviewed the implementation of RFID technology in libraries, and suggested developing RFID technology for

library search with a small benefit of knowing whether the books are placed in respective shelves.

### 1.1 IMPORTANCE OF RFID COMPARED TO BARCODE

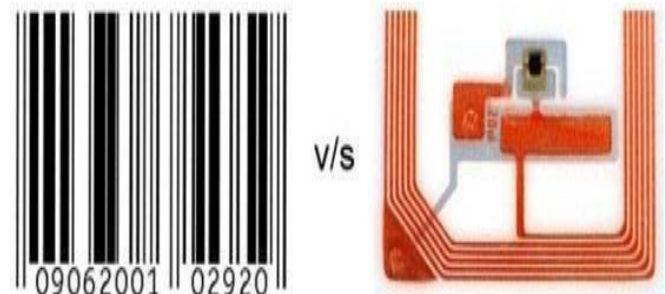

**Fig-1 Barcode and RFID Reader**

The bar code is a representation of textual information by printed symbol consisting of vertical bars while RFID uses electromagnetic waves. The figure below shows a bar code and RFID tag. Barcodes are designed to be scanned one at a time whereas many RFID tags can be scanned at once. Barcodes requires that the scanner maintain a line-of-sight with each code, while RFID is a “near field” technology, So the scanner only needs to be within range of the tag to read it. Barcodes are generally printed on paper or adhesive label, so they are prone to wear and damage, while an RFID tag is generally a tougher product that can withstand more abuse. The type and volume of data on barcodes is more limited than what can be stored on an RFID tag.

	RFID	BARCODE
Read Range	It has range up to 40 feet .	Barcode can read several inches
Read rate	RFID can read multiple tags simultaneously.	Barcode can read only one tag at a time.
Identification	Can uniquely identify each item tagged.	Most barcodes only identify the type of item but not uniquely.
Read/write	RFID tags support both read and write operations.	Barcode support only read operations.

**Fig-2 Difference between RFID and Barcode**

## 1.2 PROBLEM STATEMENT

The current library manually returns the book to the bookshelf. The librarian has to collect the returned book and use trolley to carry those books to their respective bookshelf. The books are then place one by one on their respective compartment. While some libraries uses barcode for their book identification. Barcodes requires line-of-sight, and cannot scan moist surface. Most misplaced books are done by students who after reading or studying the book try to replace the book back to the shelf it was taken from but are not familiar with the Library book and Shelf arrangement therefore misplacing the book. As observed, without RFID based bookshelf identification system, students and/or librarians.

- Will spend more time searching for the correct bookshelf to place the book back even with the use of barcodes.
- Will not know the exact location of misplaced books.

## 2. BLOCK DIAGRAM

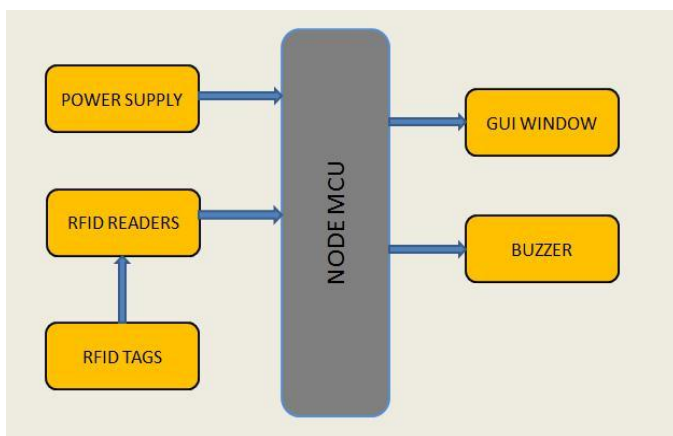

Fig -3: Block Diagram

## 2.1 RFID TECHNOLOGY

The RFID Transponder is simply known as Tags (RFID Card, etc) which is always placed on the object or person to be located. While the Interrogator is the RFID Reader which could be of different type and design depending on the purpose for which it is to be used. It is the device that reads and locates the tagged object or person. Radio frequency identification systems are small low cost tags on objects in order to track their positions [3] Hilal Ahmad(2017)RFID Technologies in Libraries. RFID systems are now being typically deployed at low (125kHz), medium (13.56MHz)

and high frequency (869MHz, 2.5GHz) bands. At 125kHz and 13.56MHz, inductive coupling is used to communicate between readers and tags, whereas electromagnetic coupling is used at 868MHz and 2.5GHz .

RFID devices can be divided into two categories:

- RFID devices with power supply (battery)
- RFID devices without power supply.

As a wireless system, the RFID tag contains a transceiver and an antenna. It can be passive, active or semi passive. A passive contain no power source, and it response only when a nearby reader power it. Passive tags have a readable distance ranging from about 10cm up to a few meters, depending on the chosen radio frequency and antenna design. Passives tags can be manufactured with a printed antenna.

The semi passive and active tags contain a battery, which is used to power the circuit. This leads to a greater sensitivity than that of passive tags, typical 20dB or more. Thus it can reach a distance that is ten times longer, or provide a better reliability. An active tag also broadcast to the reader, thus it is much more reliable even in a very adverse RF environment, or can reach a range of 500m, but with a shorter life .Semi passive tags use the battery only to power the circuits, but not to broadcast the signal. Like a passive tag, a semi passive tag uses the RF energy received from the reader to respond. The battery may also store energy from the reader[4]Bansode ,S.Y.& Desale,S.K. (2009).

## 2.2 RFID(Transponder) Tag:

An RFID transponder also known as RFID tag is a device that has an antenna and transceiver and is capable of storing and transmitting data to a reader. There are various sizes of an RFID tag. Some are seen in Figure 2.2 below



Fig-4: RFID TAG

[5] Bi, C.,Cao,J.,& Sheng,X.(2011) RFID Identification and its types technology stated that when choosing a tag, some features must be considered, and they are: The operating frequency of the RFID tag to be used, the size of the RFID tag,

the range of the RFID tag, the data capacity of the RFID tag, the environmental condition (where the tag will be used) of the RFID tag, and importantly, the kind of RFID tag (passive, semi active, or active) to be used.

**2.3 TYPES OF RFID TAGS:**

There three types of RFID tag which does not operate in the same frequency range and data transfer rate; they are Passive Tag, Semi-Active Tag, and Active Tag.

**PASSIVE RFID TAGS**

An RFID Passive tag is a tag that has no internal source of power but strongly on electromagnetic principles to receive power from the RFID reader.

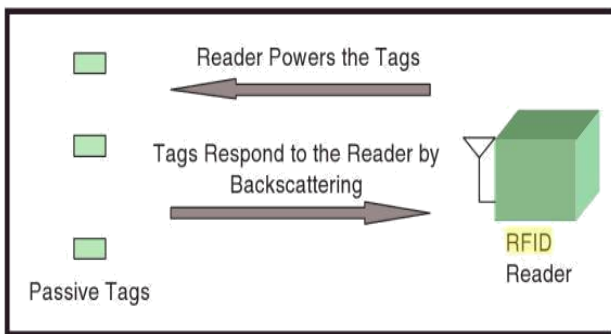
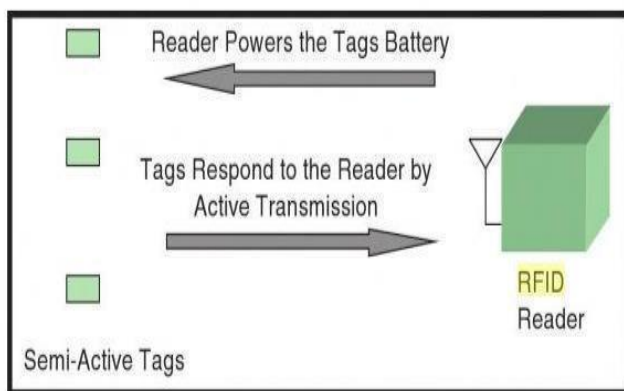

**Fig-5: Passive RFID tag**

Some basic features of a passive tag is that they are cheap and smaller than semi-active and active tag, they have high resistance to harsh weather and unlimited life span.

**SEMI ACTIVE RFID TAG:**

An RFID Semi – active tag is a tag with an internal battery that only helps in conserving the received energy in the IC but not for the transmission of data. The conserved energy helps to power the digital logic on the chip. See figure 2.4

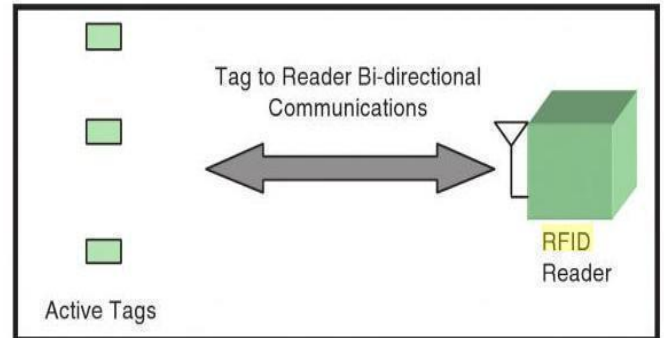

**Fig -6: Semi Active RFID Tag**

Some features of this tag is that they are more reliable and have greater read range than the passive tag.

**ACTIVE RFID TAG:**

An RFID Active tags are tags that uses its internal power source (battery) for communication with the RFID reader, so that it does not require the reader’s emitted power to transmit. This is seen in figure

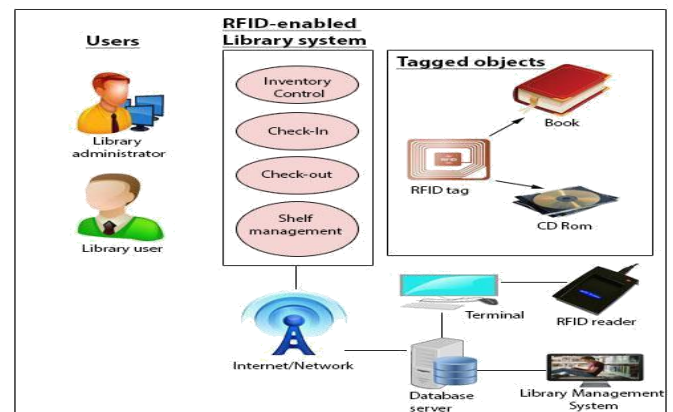

**Fig -7: Active RFID tag**

**2.4 BACK SCATTERING AND HANDSHAKING:**

The backscattering is a method by which a Passive and Semi – active tags sends data and receives signals from the RFID reader. The signal received by the tag powers up the tag by generating energy of about 1.2V in the microchip and then it generates signal and sends it back to the reader. Handshaking is a continuous generated radio frequency (RF) carrier sine wave in the RFID reader which is only applicable in a passive tag.

If the reader’s RF is received by the tag, energy is generated to operate appropriately and divides the carrier signal and starts clocking its data to an output transistor connected across the coil input. [2]Mohd Kamir Yusof(2016) Adoption and of RFID.



**Fig -8: RFID tags**

## 2.5 RFID (INTROGATOR)TAG

The RFID Interrogator also known as reader is a transceiver device whose antenna receives signals from RFID tags (Active and Semi-active tags) or reflects signals by backscattering method to the RFID tags (Passive and Semi-active tags). That is to say, the RFID reader is the connector between the system and the tags to be identified.[6] (Nekoogar, & Dowlas, 2011). More details of the RFID reader is noted in the operation of RFID section of this report. output.



Fig-9: RFID Reader Module (EM-18)

## 2.6. RFID CARD :



Fig-10: RFID card

The card is an electromagnetic device where it Produces current only when RF signal is detected from the reader. The card has built in antenna.

## 2.7. RFID OPERATION :

RFID structure consists of three layers: RFID tag, RFID reader and application. Fig 9.The RFID tags consist of coils which make up the antenna. The package is a material used to firmly hold the coils. There is no voltage source in the RFID tag.

The voltage source is depends on the RF signal transmitted from the RFID reader. The interfacing between RFID tag and the RFID reader is through the air.

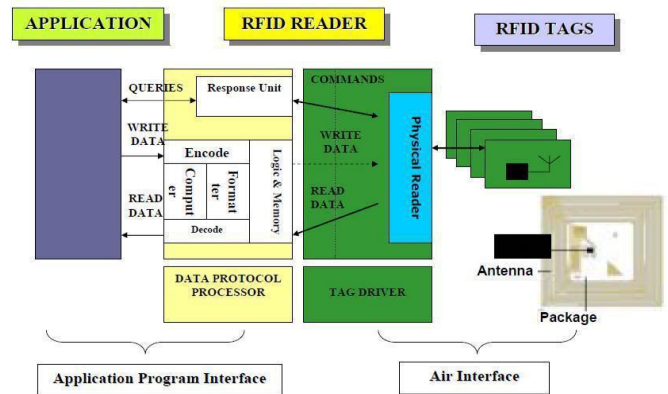

Fig-11: RFID Structure

The distance of interfacing should be around 0cm to 50cm. Depends on the product of the RFID readers, some RFID readers allow more than 50cm of communication with the tags but about 6cm is used for this project. In the RFID reader, there will be a command to write and read data. The writing and reading of data are interfaced with a data processor. In the data processor, one can see the memory, encoder and decoder. The memory is used to store the information of the RFID tag. When transmitting the information, the information will be encoded.

When receive the incoming information, the information will be decoded. Hence, the RFID reader works as a two ways communication (transceiver).The RFID is powered up by 12V DC. Normally the reader has three outputs: queries, write data, and read data. To call the data, a microcontroller must be used and programmed to interface with the three outputs[7] (Pengelly, & Vendellin, 2010).

## 2.8. NODE MCU :

Node MCU is an open source platform. It includes firmware which runs on the ESP8266 Wi-Fi and hardware which is based on the ESP-12 module. The term "Node MCU" by default refers to the firmware that uses the Lua scripting language. A multipoint control unit (MCU) is a device commonly used to bridge videoconferencing connections. The multipoint control unit is an endpoint on the LAN that provides the capability for three or more terminals and gateways to participate in a multipoint conference. NODEMCU which is a ESP8266 Wi-Fi Module is a self-contained SOC with integrated TCP/IP protocol stack that can give any micro controller access to your Wi-Fi network.



Veloso, Artur F.: Sousa, Beatriz A.: Braz, Arleide R.:M.: Lima, Erick M.S(2017), identification of node mcu in smart cities. The ESP8266 is capable of either hosting an application or offloading all Wi-Fi networking functions from another application processor. NodeMCU board used in our project is Node 1.0 ESP-12E.

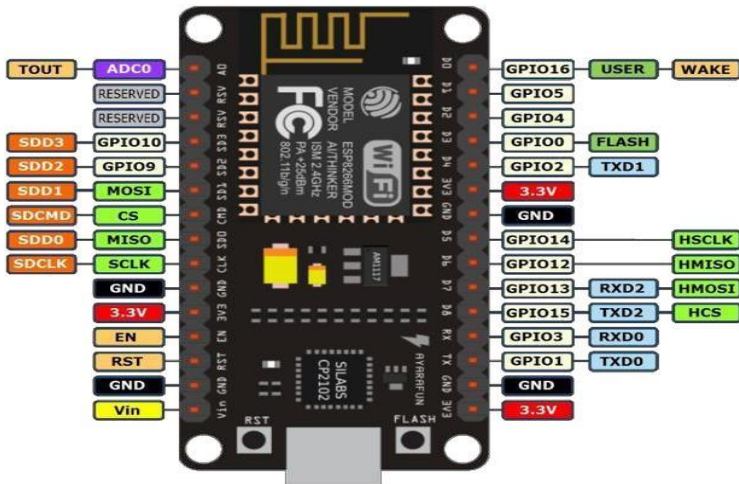

Fig-12: Configuration of Node Mcu

### 2.9. NODE MCU (ESP320):

ESP32 is a series of low cost, low power system on chip micro controllers with integrated Wi-Fi and dual-mode Bluetooth. The ESP32 series employs a Tensilica Xtensa LX6 microprocessor in both dual-core and single-core variations and includes in-built antenna switches, power amplifier, low-noise receive amplifier, filters, and power management modules.

NodeMCU ESP32 is already integrated antenna and RF , power amplifier, low-noise amplifiers, filters, power management module. The entire solution takes up the least amount of printed circuit board area. This board is used with 2.4 GHz dual-mode Wi-Fi and Bluetooth chips by TSMC 40nm low power technology, power and RF properties best, which is safe, reliable, and scalable to a variety of applications.

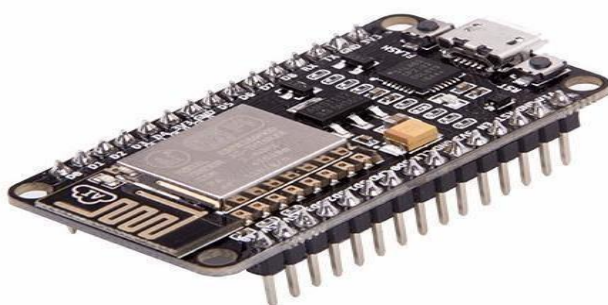

Fig-13: Node mcu

### 3. WORKING PROGRESS:

The delivery model of our project design of racks, RFID reader, RFID tags, laptops, systems, mobiles etc play a major role in reducing the burden of the librarians. RFID functionality is divided into four application categories: tracking, shelf management of resources, self-service and self-sufficiency, and security. RFID will be placed in the shelves. And the RFID tags will be sticken in every books of the library.

An RFID reader will read the data from the RFID tag and transmit the data in radio wave to the library system. when books which are placed in their respective shelves are being taken by the users. The RFID will send the message to the system that the books have been taken from the respective shelves. After viewing this through the system the librarian can send notification to the users or students. The users can get the notification that the books have been issued to them and this book should be returned within the respective due date without fail.

This system also has an advantage of knowing about the placement of books, if the books are placed in wrong rack then the RFID tag will send a pop message to the librarian that the books are misplaced and the book should be placed in the respective shelves. This kind of information to the librarians will reduce the burden of the librarians. At the same time it is not necessary for them to go and monitor continuously for hours whether the books are placed correctly in the shelves. These kinds of technology should be used in the bigger libraries there it takes huge time for the librarians to check the books.

### 4. HARDWARE AND SOFTWARE RESULTS:

#### 4.1 PROTOTYPE MODEL:

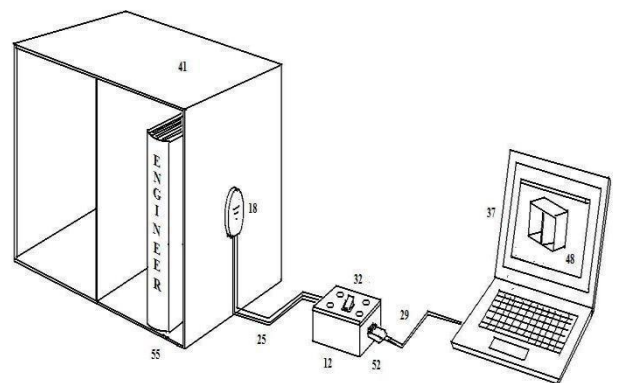

Fig-14: Prototype Model

The above prototype model describes how this project is going to be designed in the future libraries in order to reduce their burden and make their work easier.

#### 4.2. HARDWARE SETUP:

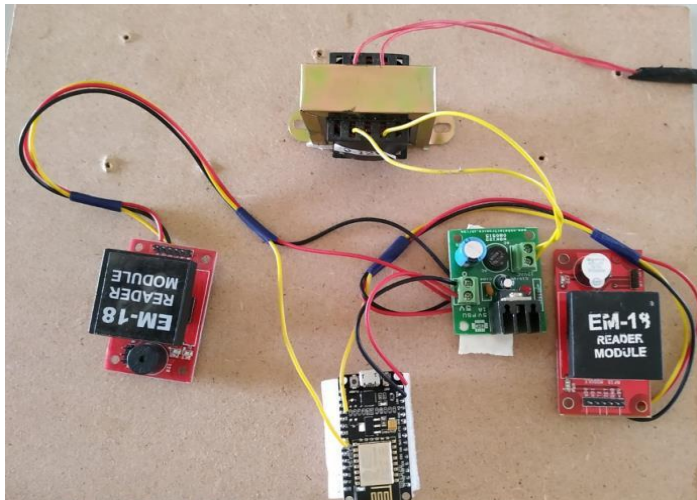

Fig-15: Hardware set up

#### 4.3. SOFTWARE OUTPUT:

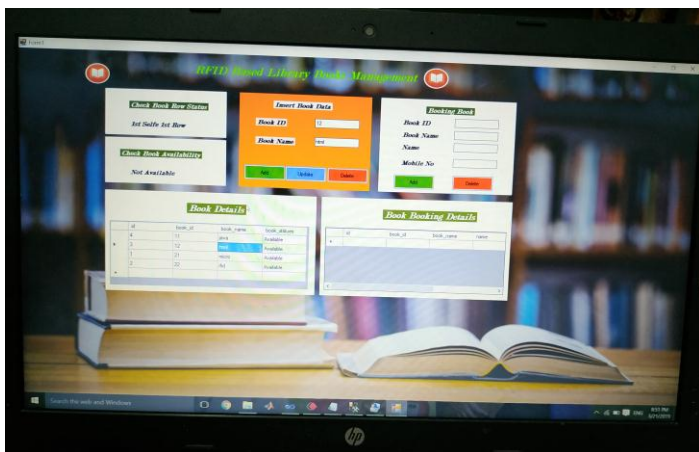

Fig-16: visual basic output

The above figure shows that it is a visual basic studio software through which the librarian is able to view the output whether the book is placed in respective shelves or not. Numbers of books are booked by the students and numbers of books are in waiting list. The librarian is also able to view whether the book is available or not for the students to be issued and received. The Librarian can also have the list of books have been booked with student details.

#### 5. CONCLUSIONS

The above review of literature indicates that using of RFID reader is better when comparable to barcode scanner and it is efficient also. Using this RFID system reduces the burden of the librarians in many aspects and allows them to know the misplacement of books with the alarm, along with these usage our project has also an advantage of viewing the misplacement of books, the book which is issued and returned in due time through the computer displayed before them. It also has an advantage of sending a notification to the students by the librarian whether the book has been issued to the students or returned to them. The due date can also been viewed by the students. It is cost efficient with fewer burdens.

#### 6. REFERENCES

- [1] Mehrjerdi (2015) RFID and its multiple case analysis”(Department Industrial Engineering, Yazd University, Yazd Iran) Assembly Automation, Issue:3,pp.251-262.
- [2] Mohd Kamir Yusof(2016) Adoption and of RFID published by WKW,school communication & Information & NTU Libraries,Nayang Technological University volume-26, issue 1,pages 31-52(2016)
- [3] Hilal Ahmad(2017)RFID Technologies in Libraries of Iqbal library ,university of Kashmir of Indian Library Association 52(4),2017.
- [4] Bansode,S.Y.&Desale,S.K.(2009).Implementation of RFID technology University of pune Library. Program: Electronic Library and Information Systems,43(2),202-214
- [5] Bi,C.,Cao,J.,&Sheng,X.(2011)RFID Identification and its types in library. In International Conference on Information Computing and its application (pp.646-651).
- [6] Nekoogar, F. & Dowla, F. (2011) Ultra-wideband Radio Frequency Identification System. United state of America: springer.
- [7] Pengelly, H. & Vendellin, G. (2010) ‘Proposed New RFID circuit’, IEEE on Electronic, 5 (11).