

IOT based E-Challan Automation for RTO using RFID

Siddhant Shivam, Tushar Teotia, Shubham Mishra & Himanshu Mittal

Student, Dept. of ECE, IMS Engineering College, Ghaziabad, Uttar Pradesh, India

Abstract - Digitization and automation is the rule of the world and is quickly growing and covering the entire nations. There were days when it started with paper based system now be it anything automation is the key for faster delivery of any system.

Key Words: Arduino; RFID; Traffic Violation; Penalty

1. INTRODUCTION

Here the people who do not follow the traffic rules will automatically be imposed to a challan and will get notified using a message on their phone about when, where and how much challan has been imposed to them. Traffic inspectors' work has minimized using the system as they don't need to stop the running or over speeding person to impose him a challan.

Basically an rfid tag will be attached to the vehicle which will have the user's information stored in them. Whenever the vehicle user crosses the traffic signal the data will be stored and sent to the server. This data will now be sent to a decision making system which will check whether the vehicle has crossed the signal on green signal or red signal. If the signal was green then no challan will be imposed and if the signal was red then a challan will be imposed automatically and the mobile number stored in the vehicle's rfid tag will receive a challan notification and the challan will also be sent to the RTO's database.

1.1 Design and Operation

Basically an rfid tag will be attached to the vehicle which will have the user's information stored in them. Whenever the vehicle user crosses the traffic signal the data will be stored and sent to the server. This data will now be sent to a decision making system which will check whether the vehicle has crossed the signal on green signal or red signal. If the signal was green then no challan will be imposed and if the signal was red then a challan will be imposed automatically and the

mobile number stored in the vehicle's RFID tag will receive a challan notification and the challan will also be sent to the RTO's database.

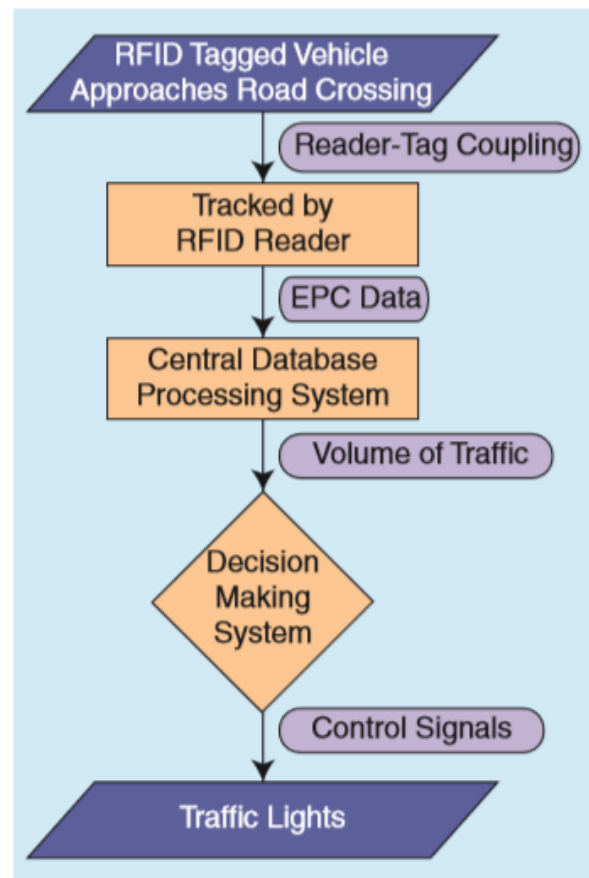

Fig 1. - Flow Chart of sequence of working

1.2 Advantages of the Project

- It enables people to follow traffic rules as we know the current scenario in UP nobody follows the traffic light.
- It reduces the police effort by generating challan automatically.
- It helps pedestrians as people will stop their vehicles before the zebra crossing.

- It will help in safeguarding unnecessary accidents happening due to people skipping red lights and not following traffic rules.
- It will enable to keep a track of RTO's challan funds and will reduce corruption.

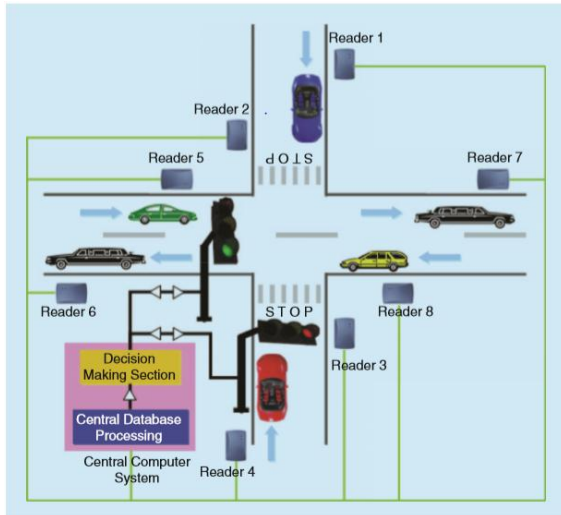

Fig 2 - Illustration of the Working of project

1.3 Uses

- It is used to control traffic and make people follow traffic rules.
- It is used for pedestrian safety enables them to cross roads safely
- It is used to reduce corruption by keeping the track of the funds of challan.

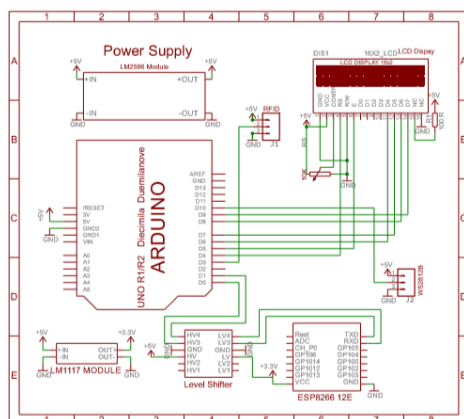

Fig 3 - Schematic Diagram of the connections

1.4 Components Used

- Arduino
- Wi-Fi Module ESP8266MCD
- LCD Display 16x2
- Step down power supply unit 3.3v
- RFID Sensor EM-18
- Rfid tags
- Jumper wires

2. SPECIFICATIONS OF MAIN COMPONENTS

1. Arduino-

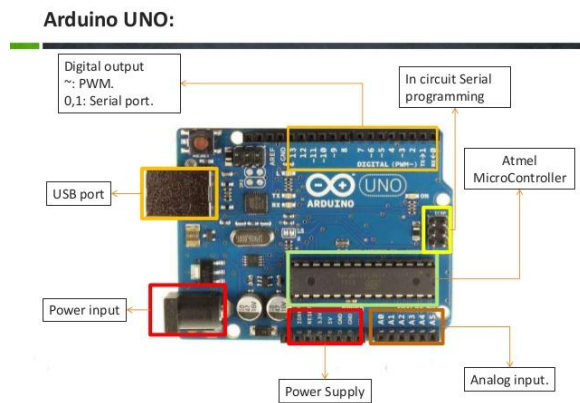

Fig 4 - Arduino Physical Layout

Arduino is an open-source electronics platform based on easy-to-use hardware and software. Arduino boards are able to read inputs - light on a sensor, a finger on a button, or a Twitter message - and turn it into an output - activating a motor, turning on an LED, publishing something online. You can tell your board what to do by sending a set of instructions to the microcontroller on the board. To do so you use the Arduino programming language (based on Wiring), and the Arduino Software (IDE), based on Processing.

2. ESP8266 Wi-Fi Module

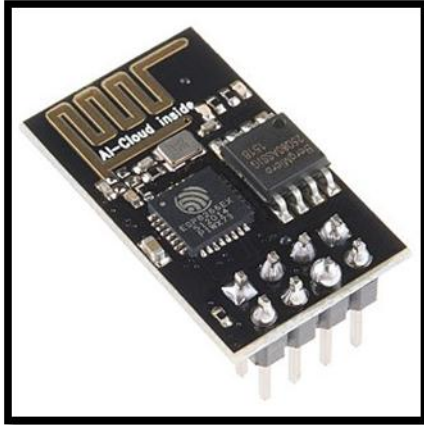

Fig 5 – ESP8266 WIFI Module

The **ESP8266** is a low-cost Wi-Fi microchip with full TCP/IP stack and microcontroller capability produced by manufacturer Espressif Systems in Shanghai, China.

Features

- Processor: L106 32-bit RISC microprocessor core based on the Tensilica Xtensa Diamond Standard 106 Micro running at 80 MHz.
- Memory:
 - 32 KB instruction RAM
 - 32 KB instruction cache RAM
 - 80 KB user-data RAM
 - 16 KB ETS system-data RAM
- External QSPI flash: up to 16 MB is supported (512 KB to 4 MB typically included).

3. RFID TAGS



Fig 6 – EM – 18 RFID Module

This module directly connects to any microcontroller UART or through a RS232 converter to PC. It gives UART/Wiegand26 output. This RFID Reader Module works with any 125 KHz RFID tags.

Specifications

- 5VDC through USB (External 5V supply will boost range of the module)
- Current: <50mA
- Operating Frequency: 125Khz
- Read Distance: 10cm
- Size of RFID reader module: 32mm(length) * 32mm(width) * 8mm(height).

3. CONCLUSIONS

Thus we conclude that in today's scenario automation in traffic system is a necessity to avoid further violation of traffic rules. It also ensures proper collection of penalties enabling a corruption free environment.

FUTURE SCOPE

This project has a great potential to automate various more aspects in transport system such as speed sensing challan, real time traffic monitoring system, illegal parking system.

REFERENCES

1. Journal of Network Communications and Emerging Technologies (JNCET) www.jncet.org Volume 6, Issue 5, May (2016)
2. International Journal of Advance Engineering and Research Development Volume 4, Issue 8, August -2017
3. Nourdine Aliane *, Javier Fernandez †, Mario Mata † and Sergio Bemposta †A System for Traffic Violation Detection Sensors 2014, 14, 22113-22127; doi: 10.3390/s141122113
4. Article, "Times of India traffic survey", Available: <http://timesofindia.indiatimes.com/india/16-deaths-everyhour-Indian-roads-claim-the>



maximum-number-of-livesin-2014/article
show/48128946.cms