

# HOME SURVEILLANCE WITHOUT USING CCTV CAMERA

P. Praveen Reddy<sup>1</sup>, P. Prudhvi Pavan<sup>2</sup>, M Devika<sup>3</sup>

<sup>1,2</sup>Student, Dept. of Electronics and Communication Engineering, Sathyabama University, Chennai, India.

<sup>3</sup>Assistant professor, Dept. of Electronics and Communication Engineering, Sathyabama University, Chennai, India.

\*\*\*

**Abstract** - An embedded system is therefore vital in today's automation. Security system is most vital and required altogether reasonably places to avoid any misbehave. Here introducing a replacement technique while not victimization CCTV camera for police work within the home, bank and every one alternative places with low value, low power and additionally avoid memory usage. This was with the mix of GSM SIM 800A, Pyroelectric infrared sensing element (PIR), unhearable sensing element and PIC microcontroller. During this technique PIR is placed within the prime of the ceiling of the locker. The most goal of our project is to avoid cupboard space of camera and extremely less power consumption.

**Key Words:** CCTV Camera, PIR Sensor, GSM SIM 800A, Ultrasonic sensor, Chloroform, Actuator.

## 1. INTRODUCTION

Surveillance is outlined as observance of activities, behavior or ever-changing info for providing higher direction, protection and security to folks. police work covers way distance exploitation equipment. Police work is one in every of the foremost necessary security systems in today's life because it protects home from felony, burglaries and murders as become routine in huge cities. police work helps in governments and enforcement for maintaining group action and investigates criminal Activities. In ancient police work systems if interloper is absent, system can't be turned OFF thence they consumes a lot of power. Additionally this technique needs a lot of memory to keep knowledge or image that is captured by camera. Therefore there's wastage of power and Memory additionally camera ought to work unceasingly. To beat this downside embedded based mostly home closed-circuit television exploitation PIR device is intended.

These sensors are usually fitted reception windows and doors in order that interloper should have it. PIR device used here is compact, straightforward to use, and cheap. It's ideal for numerous applications as warning device, robotics, and motion activated lightening etc. This high sensitivity, low noise PIR device used for physique detection, notice motion up to six meter. PIR detector (device) compromises of crystalline element material therefore it generates electrical phenomenon when exposure to infrared. Containing special filter that is Fresnel lens, therefore it focuses infrared signals onto part. Detection of motion is completed by PIR device in

terms of warmth that is emitted by encompassing objects. It leads to motion once unexpected modification happens in encompassing IR patterns. Thence its output pin results logic HIGH signal. Microcontroller reads this logic HIGH signal. PIR device works properly once it's "warmed up" by time. The time varies in between 1-2 minutes. This PIR device solely accepts passively incoming infrared, it doesn't emit infrared. PIR detects presence of entrant and it generates pulse that is browse by MCU.

Here PIC16f877A is employed. It's associate ASCII text file physical computing platform that relies on easy microcontroller board, conjointly development atmosphere for writing computer code for the board. PIC is helpful for developing interactive objects, it conjointly take inputs from a unique forms of switches or sensors, and dominant a range of lights, motors, and different physical outputs.

## 2. PROPOSED SYSTEM

### 2.1 Block Diagram

The PIR sensor and Ultrasonic are the two sensors which detects the thief when entered into the home .The output of the PIR sensor and Ultrasonic are send into the PIC 16F877A microcontroller when thief's are detected the input from the controller activates RB0,RB1,RB2 pins which is the output that is the input to the motor driver where it clearly shown in the block diagram the actuator and it rotate in clockwise for 5seconds that time chloroform is pressed and again it rotate in the anticlockwise directions.

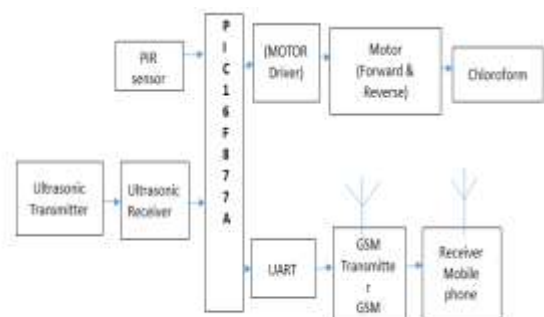

Fig -1: Block diagram for proposed system

GSM SIM 800A module which is the transceivers that sends the data of "Thief entered into the home" by the PIC 16f877A microcontroller and the receiving unit which receives the signal from the PIC controller is mobile.

### 2.2 Flow Diagram

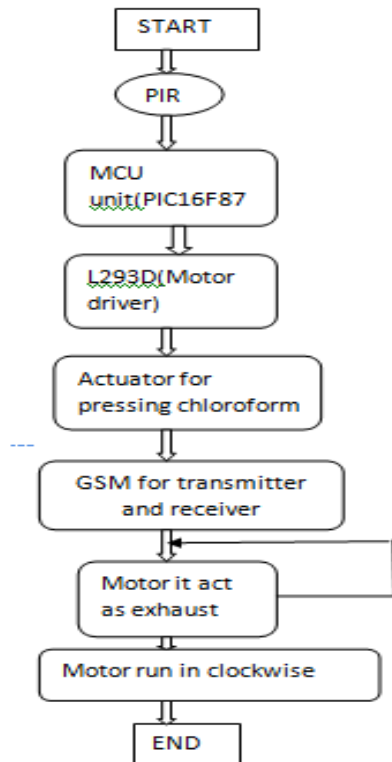

Fig -2: Flow diagram for Proposed system

The flow diagram shows that the working of this project at first PIR Sensor ON then it transfer the signal to the PIC16f877A then the makes it RB0, RB1, RB2 as output then L293d IC for actuator to enable for the rotation in both forward and reverse direction.

The GSM module was connected in RC6 pin for transmitting the data of "THIEF ENTERED INTO THE HOME" to the authorized person and then after a few seconds exhaust automatically ON it runs the direction of clockwise.

### 2.3 Model Working Diagram

The sensor is place in the detection state ultrasonic sensors and PIR sensors are used to sense an intruder. The PIR sensor circuit has a placed on the ceiling of the specific room environment.

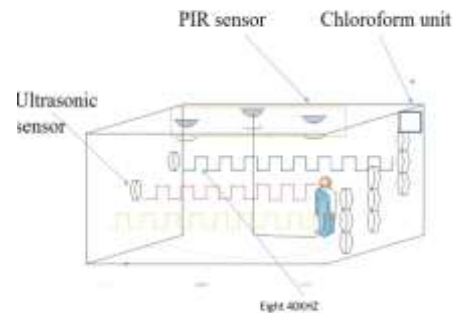

Fig -3: Hardware View

From model working diagram make us to understand the concept easily and clearly from this we understand ultrasonic sensor is fitted on the wall that Transmits 40KHZ output signal to the receiver side when the signal is cute by the thief the alarm is on outside the home. The MCU stays during a sleep state, unlike the traditional surveillance system which stays in the detection state.

### 3. MODULES

#### 3.1 PIR Sensor

The normal sensor emits the radiation but in this sensor detect the radiation. All the objects with a temperature higher than temperature emit energy within the kind of radiation. Usually this radiation is not visible by human eye because it radiates at infrared wavelengths, but in this infrared be detected by electronic devices designed for detecting the human movement. The PIR Sensor detects range of approximately 20 feet (6 meters).The detector is meant to spot the slowly dynamic conditions that will happen ordinarily because the daily progresses and therefore the condition changes, but it responds by making its output when explosive changes occur, such as when there is motion. Device is designed mainly for indoor use. Operation outside or in terribly high temperatures might have an effect on stability negatively.



Fig -4: PIR Sensor

### 3.2 Ultrasonic Sensor

Ultrasonic sensing element is non-contact distance activity module that is additionally compatible with electronic brick. It's design for easy modular project usage with industrial performance. A short inaudible pulse is transmitted at the time zero, reflected by an object. The adult male receives this signal and converts it to an electrical signal. The next pulse is transmitted when the echo is faded away. This time period is called cycle period. The recommend cycle period is not less than 50ms. If a 10µs width trigger pulse is sent to the signal pin, the Ultrasonic module is given output eight 40 kHz ultrasonic signal and detects the echo back. If no obstacle is detected, the output pin gives a 38ms high level signal.



Fig -5: Ultrasonic Sensor

### 3.3 PIC16F877A IC

PIC is furthermore a group of changed Harvard vogue microcontroller made by semiconductor innovation, got from the PIC1650 initially created by General Instrument's material science Division. The name PIC is referenced as "Fringe Interface Controller". PICs territory unit very much enjoyed each modern engineers and specialists as a result of their low worth, wide openness, availability of low esteem or free improvement apparatuses, and sequential programming (and re-programming with blaze memory) ability.

Microchip presented the new PIC32MX group of 32-bit microcontroller's works at 2.3V to 3.6V supply voltage with 80 MHz recurrence. The underlying gadget line-up is predicated on the exchange typical MIPS32 M4K

Core. The gadget is modified utilizing the Microchip MPLAB C Compiler for PIC32 MCUs. PIC microcontroller is the main RISC based microcontroller manufactured in CMOS (corresponding metal oxide semiconductor) that utilizes separate transport for guidance and information permitting Simultaneous access of program and information memory. The fundamental preferred standpoint of CMOS and diminished guidance set PC blend is low power utilization prompting an outrageously modest chip measure with a little stick check.

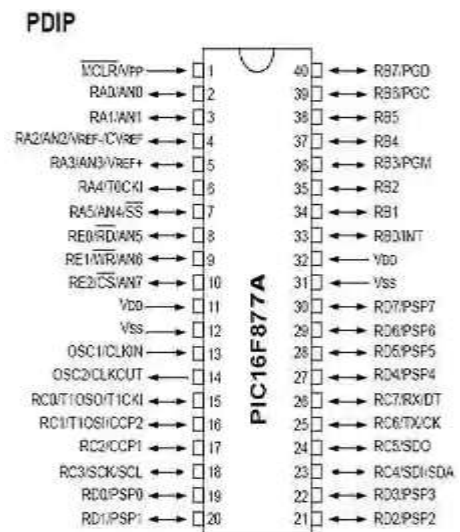

Fig -6: PIC 16F877A IC

### 3.4 L293D IC

L293D could be a twin H-bridge motor driver computer circuit (IC). Motor drivers act as current amplifiers since they take a low-current management signal and supply a higher-current signal. This higher current signal is employed to drive the motors. L293D contains two inbuilt H-bridge driver circuits. In its common mode of operation, two DC motors be driven simultaneously, both in forward and reverse direction.

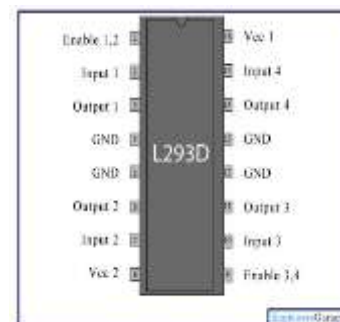

Fig -7: L293D Motor driver IC

Input logic 00 or 11 stop the corresponding motor. Logic 01 and 10 rotate it in clockwise and anticlockwise directions, respectively. When Associate in Nursing modify input is high, the associated driver gets enabled. As a result, the outputs become active and add section with their inputs. Similarly, once the modify input is low, that driver is disabled, and their outputs are off and within the high-impedance state.

### 3.5 GSM SIM 800A

The GSM stands for world System for Mobile Communications. GSM SIM 800A it does not include GPRS it comes in the form quad band only and various version like SIM 800C has Bluetooth, SIM 800L has FM, SIM 800F is pin compatible to SIM900 model, SIM 868 has Dual SIM version. In SIM 800 GSM module have inbuilt Bluetooth Stack completed with 3.0 .It operate at 3.4V to 4.4V. In this technology is used to the communication purpose, it operates at a baud of 9600bps in commonplace UART model through AT Commands. This GSM Modem is accept any of the 2G or 3G network operator SIM card and act like as mobile phone with its unique phone number. Advantage of using GSM modem that it is use RS232 port to communicate and develop embedded security applications or any other applications.



**Fig- 8:** GSM SIM 800A

GSM module is used to SMS Control, data transfer, remote control and logging be developed easily. The modem is either be connected to PC serial port directly or microcontroller. It is used to send and receive SMS or make/receive voice calls. GSM module is a highly flexible for plug and play quad band GSM module for direct and easy integration to RS232 applications.

### 3.6 Actuator

A mechanism may be a element of a machine that's liable for moving and dominant a mechanism or system, as an example by gap a valve. In Simple terms, it is a "mover". A mechanism needs an impact signal and a supply of energy. The management signal is comparatively low energy and will be electrical voltage or current, gas or hydraulic pressure, or maybe human power. Its main energy supply could also be an electrical current. When it receives an impact signal, Associate in nursing mechanism responds by changing the signal's energy into mechanical motion. A mechanism is that the mechanism by that an impact system acts upon Associate in Nursing setting. The

control system can be simple software based (e.g. a printer driver, automaton management system), a human, or the other input.



**Fig -9:** Actuator

### 3.7 Chloroform

Chloroform-d is an isotopologue of chloroform with a single deuterium atom.  $CDCl_3$  may be a common solvent employed in NMR spectrometry. Deutero chloroform is made by the halo type reaction the reaction of ketone (or ethanol) with bleaching agent or blanching agent. The halo type method is currently obsolete for the assembly of standard chloroform. Deuteriochloroform be prepared by the reaction of sodium deuterioxide with chloral hydrate.

### 3.8 PIC Development Kit

PIC Board is used to program PIC16F877A IC it contains real time clock, 7segment displays and keypads externally connected with it. A microchip development board may be a computer circuit board containing a microchip and also the nominal support logic required for associate engineer to become conversant in the microchip on the board and to learn to program it. It additionally served users of the microchip as a technique to epitome applications in merchandise.

Unlike a general system like a data processor, typically a development board contains very little or no hardware dedicated to a computer programmer. It have some provision to just accept and run a user-supplied program, such as downloading a program through a serial port to flash memory, or some form of programmable memory in a socket in earlier systems.



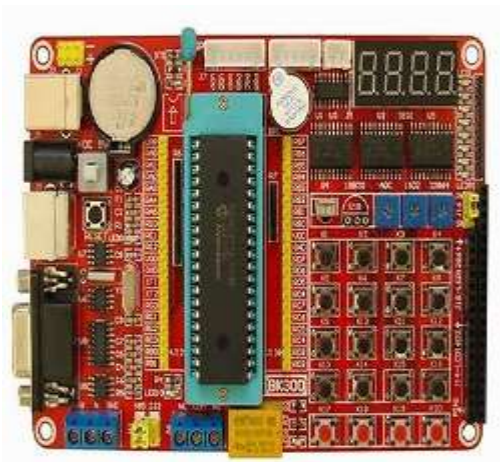

Fig-10: PIC Development kit



Fig -13: Project Output

#### 4. RESULTS

The project "HOME SURVILLANCE WITHOUT USING CCTV CAMERA" is helps to surveillance the locker with the help of PIR sensor. PIR detects the IR signal and transfer about the IR signal into the PIC micro controller. On the activation of PIC microcontroller it activates the actuator suddenly for pressing the chloroform. GSM suddenly ON and transfer as message with the data of "THIEF ENTERED INTO THE HOME". After 5seconds exhaust fan is activated. The components is taken from the Proteus library like PIC 16F877A,PIR sensor,L293D,DC motor,5v power supply and components is connected with the PIC microcontroller with the GPIO pin configured in the program.The generated (.hex) file is dumped in the PIC microcontroller and the simulation is played for checking circuit running or not. The simulation output is runs without an error finally expected simulation output is achieved successfully.

Real time Simulation output is taken after the Proteus simulation output. Its connection was made correctly and their output was taken successfully.The GSM module is connected with the PIC board using the serial communication port. Since the module has RS232 port and the PIC can communicate using TTL logic levels a max232 IC is used to make a bidirectional conversion between the RS232 and TTL logic levels.



Fig- 14: Mobile Output

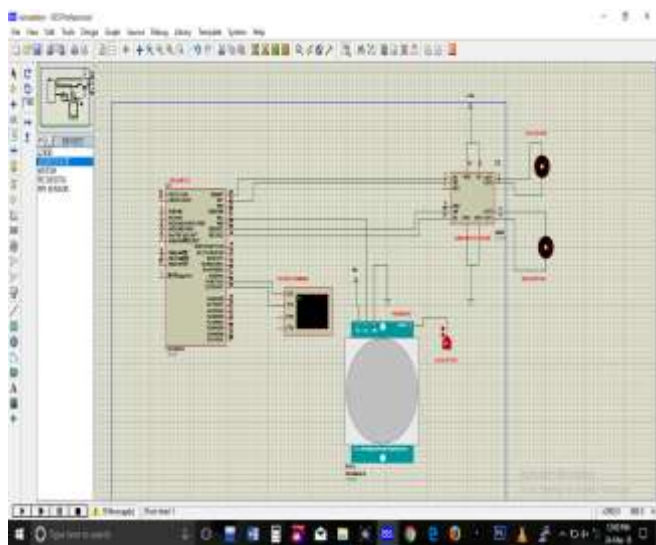

Fig: 12: Simulation Output

#### 5. CONCLUSIONS

From the above figure shows the output from the GSM number of "Thief entered into the home" to the mobile number as normal text message from the GSM command of AT+CMAT+CMGF=1 and AT+CMGS.

AT+CMAT+CMGF=1 is used to change GSM Module to Message mode AT+CMGS="+918500803268" is used to send the text message to the mentioned number.The project helps to protect home from thief, burglars as which mostly in big cities. The project embedded surveillance is designed with of many sensors like Ultrasonic and PIR which detect the unauthorized person or intruder. "Thief

entered into the home" data is shipped to the approved person selection through GSM SIM 800A. The main aim of the project is to reduce unnecessary memory for the capture of images without an intruder when comparing to previous year projects. Reduce the power consumption in the alert or sleep state by 10.9 times by remaining 90% in the alert state and 10% in the detection state, and use two sensor groups to enhance the detection dependability of the alert state. Home embedded closed-circuit television reduces reserve memory consumption for the capture of pictures while not associate degree trespasser, compared to previous police work systems.

## REFERENCES

- [1] A. J. Izenman, "Linear discriminant analysis," in *Modern Multivariate Statistical Techniques*. New York, NY, USA : Springer, pp. 237–280, 2013.
- [2] A.Mahmoud, V.M.Patel, and T.Damarla, "Discrimination of bipeds from quadrupeds using seismic footstep signatures," in *Proc. IEEE Int. Geosci. Remote Sens. Symp. Jul. 2012*, pp. 6920–6923. P. Bradley, "The use of the area under the ROC curve in the evaluation of machine learning algorithms," *Pattern Recognition*, vol.30, no.7, 1997, pp. 1145–1159.
- [3] C. Cortes and V. Vapnik, "Support-vector networks," *Mach. Learn.* vol. 20, no. 3, pp. 273–297, 1995.
- [4] C.-C. Chang and C.-J. Lin, "LIBSVM: A library for support vector machines," *ACM Trans. Intel. Syst. Technol.*, vol. 2, no. 3, pp.27, 2011.
- [5] C. M. Bishop, *Pattern Recognition and Machine Learning*, vol.1. New York, NY, USA: Springer, 2006.
- [6] D. Michie, D. J. Spiegel halter, and C. C. Taylor, *Machine Learning, Neural and Statistical Classification*. Upper Saddle River, NJ, USA: Ellis Harwood, 1994.
- [7] G.E.A.P.A. Batista, R. C. Prati, and M. C. Monard, "A study of the behaviour of several methods for balancing machine learning training data," *ACM SIGKDD Explorations Newsletter*, vol.6, no. 1, pp. 20–29, Jun. 2004.
- [8] G. Halfacree and E. Upton, *Raspberry Pi User Guide*, 1st ed. Hoboken, NJ, USA: Wiley, 2012.
- [9] G .P. Succi , D. Clapp, R .Gampert and G. Prado, "Footstep detection tracking", *Proc. SPIE*, vol. 4393, pp. 22-29, Sep 2001.
- [10] H. O. Park, A. A. Dibazar, and T. W. Berger, "Protecting military perimeters from approaching human and vehicle using biologically realistic dynamic synapse neural network," in *Proc. IEEE Conf. Technol. Homeland Secure*, pp. 73
- [11] H.O.Park, A. A. Dibazar, and T. W. Berger, "Cadence analysis of temporal gait patterns for seismic discrimination between human and quadruped footsteps," in *Proc. IEEE Int. Conf. Acoustic. Speech Signal Process.* pp. 1749–1752, Apr. 2009.
- [12] I. Bisio, A. Delfino, F. Lavagetto, and A. Sciarrone, "Enabling IOT for in-home rehabilitation: Accelerometer signals classification methods for activity and movement recognition," *IEEE Internet Things J.*, vol.4, no. 1, pp. 135–146, Feb. 2017.
- [13] J. Akram and D. Eaton, "Adaptive micro seismic event detection and automatic time picking," *CSEG Annul. Conv.*, vol. 15, pp. 1–5, 2012.
- [14] J. Davis and M. Goad rich, "The relationship between Precision-Recall and ROC curves," in *Proc. Int. Conf. Mach. Learn.*, New York, NY, USA, , pp. 233–240, 2006
- [15] J. Lan, T. Lan, and S.Nahavandi, "A novel application of a micro accelerometer for target classification," *IEEE Sensors J.*, vol.4, o.4, pp.519–524, Aug. 2004.