

SMART HOME AUTOMATION SYSTEM USING 8051 MICRO-CONTROLLER

RISHABH MALHOTRA¹, SAIYED MOHAMMAD SAAD¹, RUCHIT SONI²

¹Indus Institute of Technology and Engineering, Rancharda via Thaltej, Ahmedabad-382115, Indus Institute of Technology and Engineering, Rancharda via Thaltej, Ahmedabad-382115,

²Assistant Professor, Electrical Engineering Department, Indus Institute of Technology and Engineering, Indus University,

Abstract - Home automation systems make the revolutionary change in the human's comfortability and also make the life easier. In this system person can control all the appliances through the smartphones. There are many technologies through they can control home appliances according to their specific range. Such technologies are ZigBee, Wi-Fi, Bluetooth, En-Ocean and GSM. By Choosing any of technology appliances can be control. This system can save time and unwanted consumption of electricity. The system is based on the embedded system and can acts as a security guard of the home. In this system it can control the temperature, humidity, gas density, water immersion of the house. The purpose of this research paper is to controlled all the home appliances through smart phone.

Key Words: AT89S51, Bluetooth, ULN Driver, Relay.

1. INTRODUCTION

There is increasing demand for good homes, where appliances react automatically to changing environmental conditions and might be simply controlled through one common device. This project presents a attainable answer whereby the user controls devices by using their only mobile phone, where control is communicated to the Microcontroller from a mobile phone through its Bluetooth interface. There are many technologies are used for smart home automation. Currently, GSM, Bluetooth, Wi-Fi, USB, ZigBee Technology. In this project we have used 8051 (AT89S51) microcontroller for controlling the entire process of this project. Bluetooth module can be employed for controlling the home appliances wirelessly. Home appliances will be turned ON and OFF when user will touch button in Bluetooth mobile application in cell phone. We can use any Bluetooth application which will send character through Bluetooth. After that controller will receive the data and compare according to their code and generate a signal and go to ULN2803 Driver then after driver will drive the relay and hence relay operate and control the different appliances. Manual system should be avoided over Automatic systems. Through this project we have tried to show real model of house and also control all appliances as a result of which power is saved to some extent. Automation is that the use of management systems and data technologies to cut back the requirement for human work in the manufacturing. automation plays an increasingly important role with in the world economy and in daily expertise. Automation might be

enhance the world economy of enterprises, society or most of humankind. For example, an enterprise that has invested in automation technology recovers its investment, or a state or country will increase its financial gain because of automation like Germany or Japan in the 20th Century. Moreover, humans are more possible to commit errors and in intensive conditions the probability of error increases, whereas an automated device can work with almost zero error. In the dangerous environment (i.e. fire, space, volcanoes, nuclear facilities, underwater, etc.) human can be replaced. Performing tasks that are on the far side human capabilities of size, weight, speed, etc. This is why this project looks into construction and implementation of a system involving Prototype to control a many of electrical and electronic systems. We are surrounded by smart devices that are capable of making decisions on their own without much human interaction. The home automation may include centralized control of electrical devices including lightings, appliances and security. Presented here is a touch-control based home automation system that can control up to eight electrical devices. Life will become simpler if we can control devices like lights, AC, fans, TV, or a music system with a remote from a distance just by pressing the button.

2. PROPOSED IDEA

This block diagram shows the operation of whole system which is going to operate by the following manner.

- Android mobile
- Bluetooth module (HC-05)
- 8051 μ Controller (AT89S51)
- Relay driver module (ULN2803A)
- Relay module (8 channel)
- Home appliances (fan, motor, light, etc.)

First of all user will open the Bluetooth app in the android phone and connect to bluetooth module after the giving the

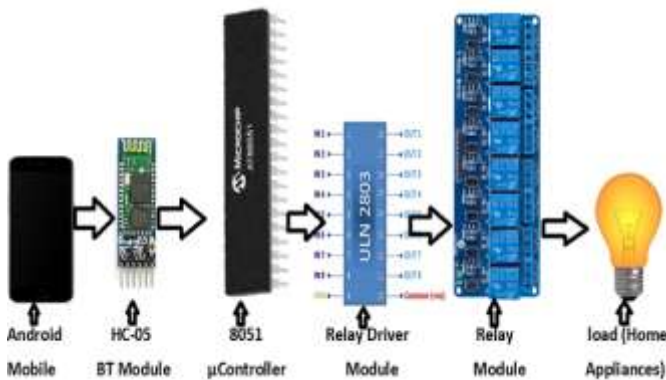

specific signal to microcontroller through Tx, Rx pin of the Bluetooth module. Then after the microcontroller reads the input data (Tx, Rx) pin from the Bluetooth and generate a signal and give to the relay driver. Which will operate the 8 channel relay.

2.1. Bluetooth module (HC-05)

The HC-05 may be a terribly cool module which may add two-way (full-duplex) wireless functionality in our projects. We can use this module to communicate between microcontrollers with any device with Bluetooth functionality like a tablet, phone or laptop. There are many android & IOS applications that are already available which made the process easier. The module communicates with the assistance of USART at 9600 baud thus it's simple to interface with any microcontrollers which supports USART. We are able to additionally set up the default values of the module by using the command mode. So, if you looking for a Wireless module that would transfer Character from your computer or mobile phone to microcontroller. And this is the best choice for us. But this module cannot transfer multimedia like, songs or photos; so for transferring the data we choose the HC-05 interface.

2.2. 8051 µController (AT89S51)

The AT89S51 is a low-power, high-performance CMOS 8-bit microcontroller with 4K bytes of In System Programmable Flash memory. By combining a versatile 8-bit CPU with In-System Programmable Flash on a monolithic chip, the Atmel AT89S51 is a powerful microcontroller which provides a highly-flexible and cost-effective solution to many embedded management applications. The AT89S51 provides the subsequent normal features: 4K bytes of Flash, 128 bytes of RAM, thirty-two I/O lines, Watchdog timer, 2 information pointers, 2 16-bit timer/counters, a five-vector two-level interrupt architecture, a full duplex serial port, on-chip oscillator, and clock circuitry. In addition, the AT89S51 is made with static logic for operation down to zero frequency and supports two software selectable power saving modes. The Power-down mode saves the RAM contents however freezes the oscillator, disabling all alternative chip functions until the next external interrupt or hardware reset.

2.3. Relay driver module (ULN2803A)

The ULN2803A is a device which has 50 V, 500 mA Darlington transistor array. The device consists of eight NPN Darlington pairs that have high voltage output which can drive the inductive load. Each pair has a 500mA collector current. For higher current capability The Darlington pairs can be connected in parallel. It can drive many of Applications include relay drivers, lamp drivers, hammer drivers, display drivers, line drivers, and logic buffers. This transistor has a 2.7kΩ series base resistor for each Darlington Legs for operation directly with TTL or 5-V CMOS devices.

2.3.1. Logic circuit of ULN2803

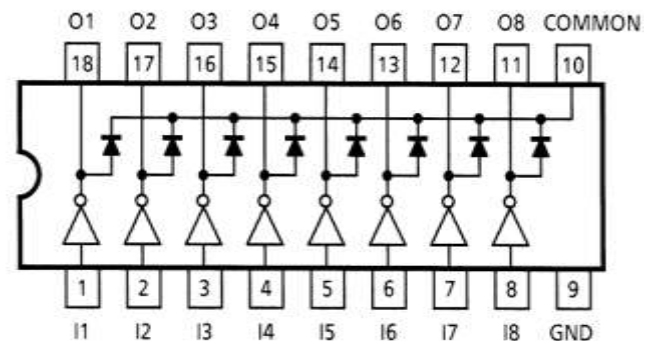

In this pin configuration 1 to 8 pin is Input pin and 11 to 18 pin is output pin.

3. FLOW CHART

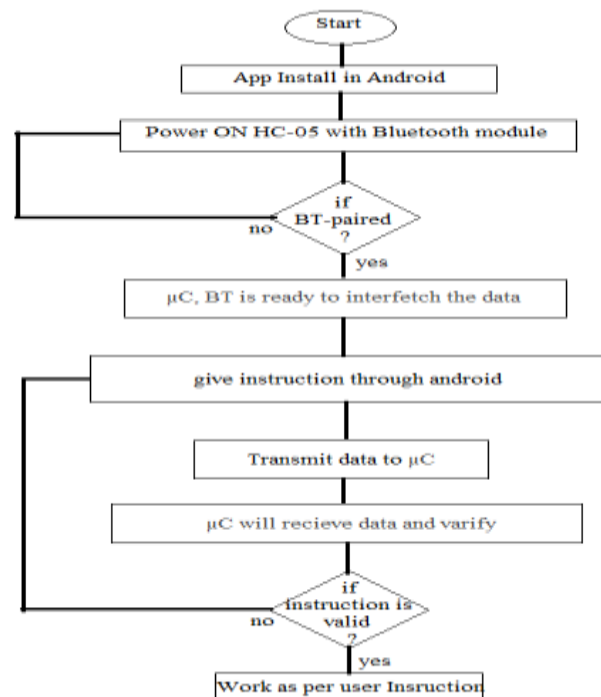

First of all, user power on the 5v rated DC supply in to Bluetooth and controller then user need to download Bluetooth application and connect with Bluetooth module HC-05 the device will paired if not paired check the connection and then connect, if user send the instruction, the Bluetooth will receive the data and send to microcontroller by Tx and Rx pin then controller will receive the data with Tx, Rx pin respectively and understand the instruction and verify with code and perform specified operation ,so then signal is generate in microcontroller port and give to ULN2803 Darlington transistor then it will drive the 8-channel relay and that way the whole operation is going to run.

4. WORKING OF MOBILE APPLICATION

Now, when user touch 'load ON' button in Bluetooth controller application then microcontroller receives 'a' via Bluetooth module and then controller Switch 'ON' the 'load ON' by using relay driver and relay and when user touch 'load Off' button in Bluetooth controller app then microcontroller receives 'b' via Bluetooth module and then controller Switch 'Off' the load by using relay driver and relay. Likewise, c, d, e, f, characters are sent by Android Phone, when load 2 On, load 2 Off, load 3 On, load 3 Off, up to 16 buttons (8 relay) has been touched respectively.

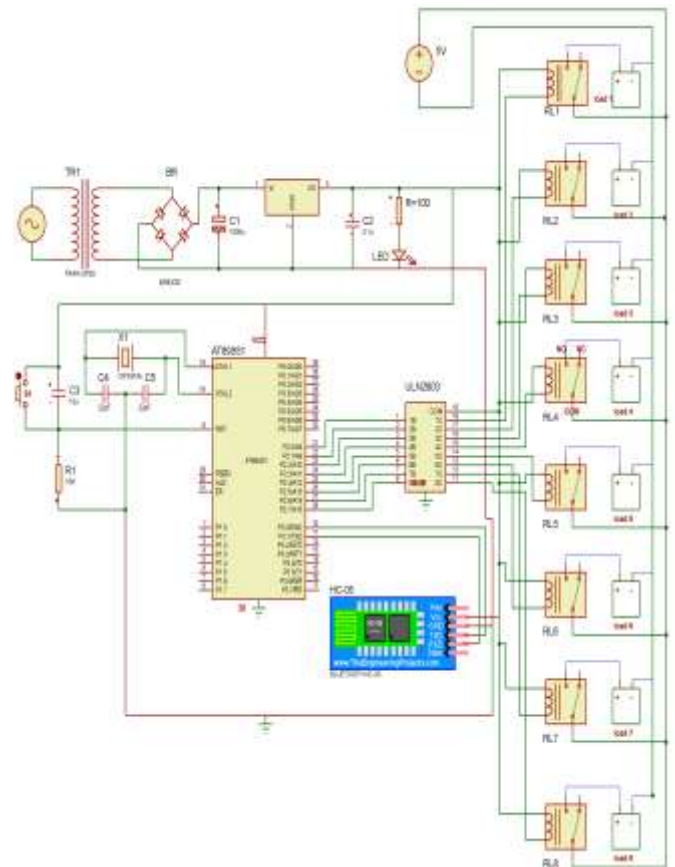

Button	ON Operation	OFF Operation
Load 1	a	b
Load 2	c	d
Load 3	e	f
Load 4	g	h
Load 5	i	j
Load 6	k	l
Load 7	m	n
Load 8	o	p

connected reset circuit to create non maskable interrupt on the 9th pin with 10µF capacitor and 10kΩ resistor. Here, to create a circuit diagram of 8051 we are internally connected reset circuit to create non maskable interrupt on the 9th pin with 10µF capacitor and 10kΩ resistor. Here, we are used default crystal frequency 11.0592 MHz with two 22pF capacitor to the ground. And we are shorted the 31 pins to VCC to fetch the internal memory. We have putted reset button to externally reset the microcontroller. In the power supply we used 12-0-12 center tapped transformer to step down the voltage and bridge rectifier are made by IN4001 diode and we put 1000µF capacitor to remove the ripples. The microcontroller requires 5v dc input so we used LM7805 IC regulator which will give 5v fixed. And also used the LED for indication purpose. After microcontroller output signal goes to ULN2803 (npn-darlington transistor array) which will drive the relay.

5. CIRCUIT DIAGRAM

In the circuit diagram we are going to on the home appliances by using Bluetooth module and relays. Here, we employed HC-05 serial communication device which will transfer the characters to the microcontroller (8051). Now, 8051 decode all characters and generate special function and it will operate the relays. Here, we are used 5v 8-channel relay. To create a circuit diagram of 8051 we are internally

5.1. Hardware Design

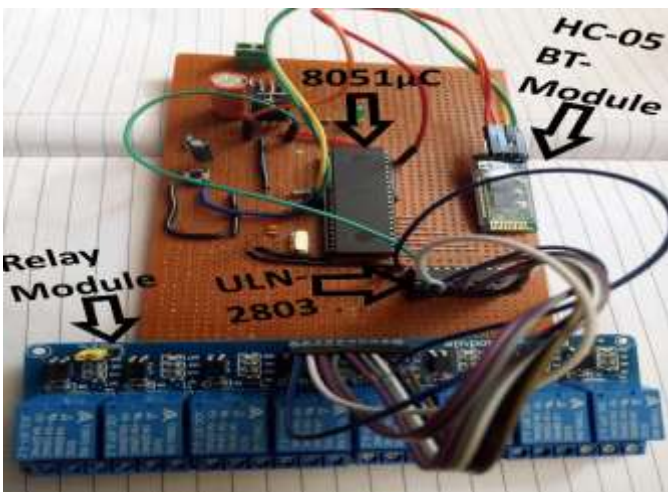
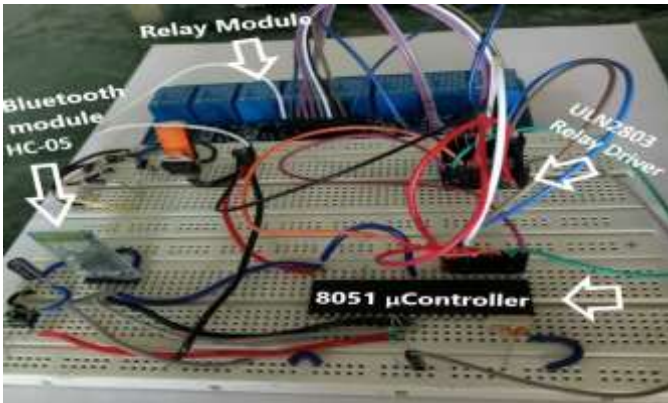

6. LITERATURE REVIEW

In today's world scenario the things are day by day getting easier for the humankind. There are many things which will be taking a revolutionary step towards the humankind. The new inventions and technologies have been done in the world for easier life and comfort. There are technologies like remote automated system are implemented in the industries. However, in the past decade, the definition has been a lot of inclusive covering big selection of applications like healthcare, utilities, transport, etc. The extensive capabilities of this method are what create it thus attention-grabbing. From a simple cell phone, a user is able to control and monitor with virtually any electrical devices. This makes it possible for users to control appliances being anywhere across the world. The end product will have a simplistic design creating it simple for users to act with.

7. PROBLEMS IN PREVIOUS RESEARCH

In previous system, GSM based Home automation system the network can be affected when a greater number of GPRS users connect at the same time, it will make a congestion and made slow data connection. In case of issue it is not easy task

to troubleshoot the problem. If GPRS is not available then system will not work. GPRS system is a little-bit expensive compare to Bluetooth system, it requires data pack for every month. Some architecture is using Bluetooth concept because it is cheap and use by anyone. some home automation system is not having some basic features like automatic control of outside light and also don't have fire alarm system to make sure they leaving a safe life.

8. FUTURE OBJECTIVE

The future implications of this project is vast, it can cover entire things to be controlled around the world. The project we have undertaken it can be taken as a grater level to show the capabilities of the system it can cover temperature updates, weather forecasting, system synchronization, etc. The project itself can be modified to achieve a complete Home Automation System which can create a platform for the user to interface between himself and his household. In future, the system will be more compact and handy with combining the microcontroller and bluetooth module. The electric failure shall not be taken place because hardware will be self-contained. This appliance will have its own power bank and charging system. This system is developed for mobile reporting application and many more. The computer system will also be interfaced to record and process data base.

9. CONCLUSION

Hence from this project we have learned a better Perspective on numerous aspects associated with our course of study as well as sensible data of electronic equipment's and Communication. The extensive capabilities of this system are What make it so interesting. From a simple mobile phone, a User is able to control and monitor with virtually any Electrical devices. This makes it possible for users to control Appliances being anywhere across the world. And also, the Television and alternative electrical appliances wasn't left running when they left the house to simply list some of the various uses of this system. The end product will have a simplistic design making it easy for users to interact with.

REFERENCES

- 1 The 8051 Microcontroller and Embedded Systems: Using Assembly and C Mazidi and McKinlay
- 2 Principles of Transistor Circuits: Introduction to the Design of Amplifiers, Receivers and Digital Circuits 7th Edition, Kindle Edition
- 3 Principles of Transistor Circuits by S.W.Amos, Mike James
- 4 HC-05 Bluetooth + Arduino Kindle Edition by Michael Wright

- 5 8051 Microcontroller: An Application Based Introduction by David Calcutt, Frederick Cowan, Hassan Parchizedeh.
- 6 Programming in ANSI C by Balagurusami
- 7 Home Automation Dummies book by Dwight Sipway
- 8 Embedded Networking with CAN and CAN open by Pfeiffer, Ayre & Keydel.