

Simulation of Unified Series Shunt Compensator for Power Quality Compensation

Reshmi Bhagwat¹, Asst. Prof. Vaishali Malekar²

¹PG student, Dept. of Electrical Engineering, T.G.P.C.E.T. College, Nagpur, Maharashtra, India

²Asst Professor, Dept. of Electrical Engineering, T.G.P.C.E.T. College, Nagpur, Maharashtra, India

Abstract - Power Quality in the circulation framework is the essential issue for mechanical, business and private applications. An expanding number of loads have driven an expanded consciousness of intensity quality both by client and utilities. This paper manages the recreation of a brought together Series Shunt Compensator (USSC), which is gone for alleviating the greater part of the power quality issues, for example- Voltage Sag remuneration, Voltage Swell pay, Voltage Flicker decrease, Voltage Unbalance alleviation, and Harmonics disposal. The demonstrating and recreation of the USSC has been completed by utilizing programming. The USSC recreation demonstrates contains two 12- beat inverters which are associated in arrangement and in shunt to the framework. A summed up sinusoidal heartbeat width tweak exchanging procedure has been created in the proposed controller structure for quick control activity of the USSC. The USSC has moderated a few power quality issues giving better execution.

Key Words: Inverter, Sag/Swell, unified series shunt compensator.

1. INTRODUCTION

Presently a days, the high caliber of electric power has turned out to be especially significance to electric utilities and for customer. Utility and client side unsettling influences result in terminal voltage changes, homeless people, and waveform bends on the electric network bringing about power quality issues. Poor power quality can influence the sheltered, solid and effective activity of the gear. Different parts of control quality are voltage droop, voltage swell, voltage unbalance, music and so forth, for power -quality enhancement, the advancement of intensity electronic gadgets, for example, FACTS and custom power gadgets have presented a developing part of innovation furnishing the power framework with adaptable new control capacities.

The presentation of FACTS and custom power idea, gadgets, for example, Unified Power Flow Controller(UPFC), Synchronous Static Compensator (STATCOM), Dynamic Voltage Restorer(DVR), and unwavering quality of a framework propelled control and progressed semiconductor exchanging of these gadgets have accomplished another period for power quality alleviation. Examinations have been completed to consider the viability of these gadgets in power quality alleviation such as list pay,

music end, unbalance pay, responsive power remuneration, and flash decrease, UPFC functions admirably for control stream control. DVR which goes about as an arrangement compensator is utilized for voltage list pay.

The STATCOM and DVR are helpful for redressing a specific kind of intensity quality issue and in this way, it is important to build up another sort of bound together arrangement shunt compensator (USSC) which can relieve different power quality issues by utilizing a brought together methodology of arrangement shunt compensators, it is conceivable to make up for an assortment of control quality issues in a dispersion framework including voltage droop remuneration, swell, unbalance voltage moderation and glimmer decrease. This paper manages the displaying and recreation of Unified Series shunt Compensator and its viability in alleviating different power quality issues.

2. BASIC CONFIGURATION OF UNIFIED SERIES SHUNT COMPENSATION

Unified series shunt compensator is a combination of series shunt inverter as shown in fig. (1) below the basic component of USSC are two 12 pulse voltage source inverter one voltage source inverter is connect in series with the line through a series injection transformer while the other is connected in shunt with the line through a shunt transformer in fig.(1).

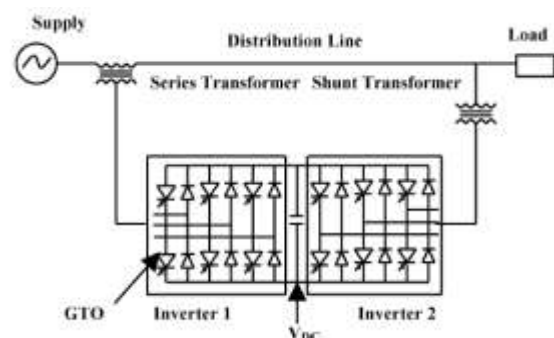

Fig.1- Basic configuration of USSC

3. CONCEPT OF THE SYSTEM –

Problem Formulation

UPQC is used to enhance the electric power quality at distribution level. UPQC is concerned about the quality of load voltage and the line current at the point of installation and it does not improve the power quality of entire system..

UPQC maintains the voltage constant under varying RLC load conditions. Therefore it provides better voltage regulations in switching of loads and improvement in the real and reactive power flow through the transmission line.

With UPQC compensation, the harmonic distortion in line current when non-linear load connected is around 5% But with passive filter, THD is about 20%.

UPQC reduces the THD by 15% compared to passive filter. So UPQC is well effective in active filtering, improvement of power quality and power factor.

Objectives

Active power filters that have been explored in shunt, series and combination of shunt and series configuration to compensate for current and voltage based distortions. It will play an improvement role for better quality solutions. Unified power quality conditioner is one of the modern and very promising PQ improving device, which consists of two APFs connected back to back on the DC side and deals with both load current and supply voltage imperfection.

The main purpose of a UPQC is to compensate for voltage flicker/imbalance, reactive power, negative – sequence current, and harmonics. In other words, UPQC has the capability of improving power quality at the point of installation on the power distribution systems or industrial power system.

UPQC consist of two voltage source converter. They are operated from a common dc link provided by a dc storage capacitor. One converter is connected in series with the line referred as series converter. The dc link is realized using a capacitor which interconnects the two inverter and also maintains a constant self-supporting dc bus voltage across it. The shunt inverter in UPQC is controlled in current control mode such that it delivers a current which is equal to the set value of the reference current as governed by the UPQC control algorithm. Additionally, the shunt inverter plays an important role in achieving required performance from a UPQC system by maintaining the dc bus voltage at a set reference value. In order to cancel the harmonics generated by a nonlinear load.

4. MODEL OF USSC

Planning of Work

In the proposed series shunt compensator the shunt compensator is designed and controlled to active power factor correction and to regulate DC bus voltage. The series compensator is used to make load voltage at the desired value so that load voltage is insensitive to utility voltage variation.

A series shunt compensator is presented to improve power quality for nonlinear and voltage sensitive load. The single phase neutral point clamp topology is used in proposed circuit to generate unipolar voltage waveforms on the AC side of the inverters. The series compensator connected between the AC source and non linear load will improve the voltage quality due to abnormal voltage sag and swell.

The shunt compensator will generate the necessary compensating current to improve the system current quality including harmonic and reactive currents and to regulate the DC link voltage. The proposed compensator can make the load voltage insensitive to source voltage disturbance and increase the input power factor to be unity.

5. MODEL DIAGRAM OF SIMULATION

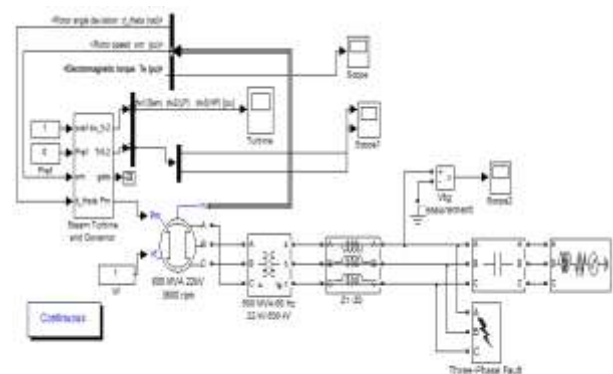

Fig. 2 -Simulation of USSC

6. Result of simulation

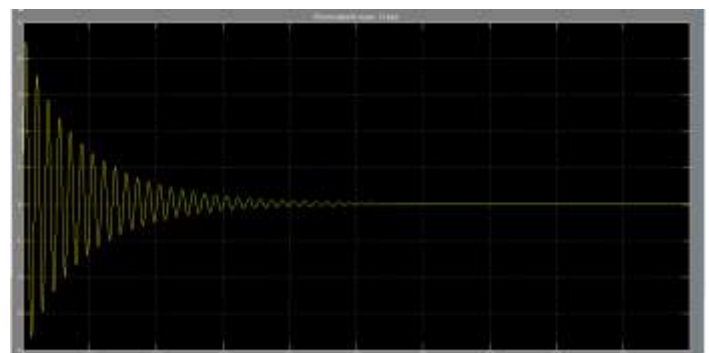

fig a – waveform of electromagnetic torque

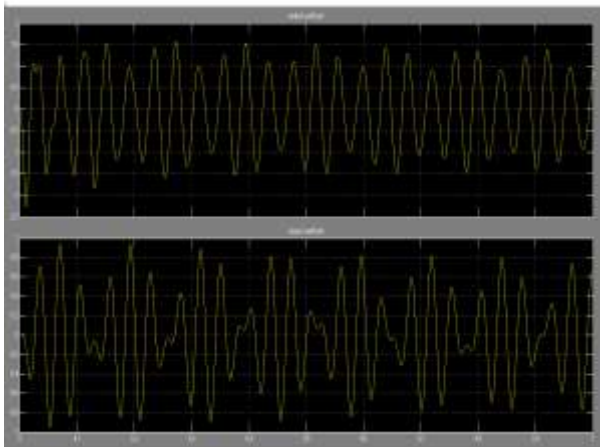

fig b - waveform of torque coefficient

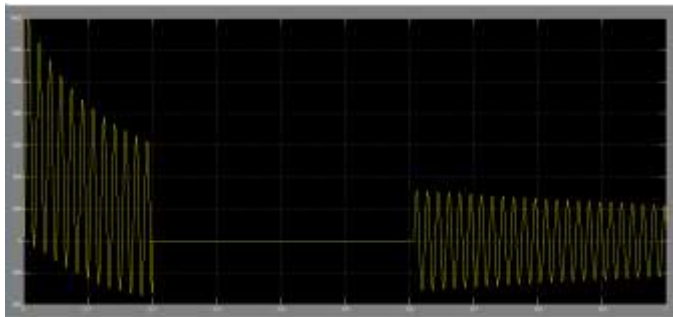

Fig c – waveform of voltage coefficient

7. CONCLUSION

The relief of various power quality issues have been examined by utilizing USSC. The two dimension USSC fusing 12 beat arrangement and shunt associated inverters has been demonstrated in MATLAB program and another SPWM- based control plot has been executed to control the GTOs of the inverters. Recreations have been conveyed out to assess the execution of the USSC under different working conditions and power quality unsettling influences. Reproduction results uncovered that the USSC can relieve viably voltage list, flash decrease, voltage unbalance and power stream control. It was too demonstrated that sounds produced by the USSC can be essentially diminished by assoiating a latent channel to the framwork. The outcomes uncovered that the USSC gives a better execution in power quality alleviation particularly in voltage list remuneration and power stream control and further more give more power quality arrangements when contrasted with the D-STATCOM and DVR.

8. REFERENCES

- 1) Abdul Majeed Khaskheli, Mukhtiar Ahmed Mahar , Abdul Sattar Larik," Power Quality Improvement in Power System Network using Unified Power Flow Controller"978-1-5386-6594-7/18/\$31.00@2018IEEE.
- 2) Mojtaba Ahanch , Mehran Sanjabi Asasi ,Heider-Ali Shayanfar,"Considering Shunt and Fixed Series Compensations in Dynamic Transmission Network Expansion Planning Using Real Coded Genetic Algorithm",2017 IEEE International Conference on Knowledge Based Engineering and Innovation (KBEI) Dec. 22nd 2017.
- 3) Petr V. Chernyaev, Maxim A. Khazov, Andrey N. Belyaev ," Operating Condition Analysis of Flexible AC Transmission Lines with Controlled Series and Shunt Compensation Devices", Institution of Energy and Transport Systems Department of electrical power system and networks 978-1-5386-4340-2/18/\$31.00@2018IEEE.
- 4) Shunsuke Tamada, Hiroshi Mochikawa, Yuji Watanabe, "Development of Continuous Series Voltage Compensator for load voltage regulation and negative sequence compensation in a 6.6kV distribution line", TOSHIBA Corporation, Power and Industrial Systems R & D Center tamada 2017IEEE.
- 5) Houriyeh Shadmehr, Riccardo Chiumeo Chiara Gandolfi,"Logical cordination between LV compensation devices to provide different PQ levels in the distribution network "978- 1-5386-0517-2/18/\$31.00@2018 IEEE.
- 6) Shaswat Chirantan, Rmakant Jena, Dr. S.C. Swain, Dr. P. C. Panda," Comparative Analysis of STATCOM And TCSC FACTS Controller For Power Profile Enhancement In A LONG Transmission Line"(ICCES 2017),978-1-5090-5013-0/17/\$31.00@2017IEEE.
- 7) Watcharin Srirattanawichaikul and Yuttana Kumsuwan," Static Series –Connected Compensator with Load –Side Connected Shunt Converter based on Single –Phase VSI for Voltage Sag Mitigation"978-1-5090-2597-8//16/\$31.00@2016IEEE.
- 8) Jarupula Somlal , Venu Gopala Rao , Narsimh Rao. Vutlapalli," Power Quality Improvement in Distribution System using ANN Based Shunt Active Power Filter"International journal of Power Electronics and Drive System Vol. 5,No. 4, April 2015.
- 9) K. Bavitra, . Sinthuja and N. Manoharan,"Effective Power Quality Improvement using Generalised Unified Power Quality Conditioner"Indian Journal of science and Technology, Vol7 (S7),191-197, November2014.
- 10) Bahr Eldin, S.M,K.S. Rama Rao, Rsdiazli Ibrahim , N. Perumal"Cascade Multi-Level Converter Based Generlized Unified Power Quality Conditioner"2012 4 th Internationl Conference on Intelligent and

Advanced System, 978-1-4577-1967-7/12/\$26.00@2012IEEE.

- 11) Md. Ashfanoo Kabir and Upal Mahbub, "Synchronous Detection and Digital control of Shunt Active Power Filter in Power Quality Improvement" 978-1-4244-8052-4/11/\$26.00@2011IEEE.
- 12) M. Basu, S.P.Das, G. K. Dubey, "Investigation on the performance of UPQC-Q for voltage sag mitigation and power quality improvement at a critical load point" IET Gener. Transm. Distrib., 2008, vol.2, No.3, pp. 414-423/415.
- 13) O. Anaya-lara, E. Acha, "Modeling and analysis of custom power systems by PSCAD/EMTDC," IEEE Trans. Power Delivery, vol. 17,no.I, pp.266-272, January 2002.
- 14) S, Ravi Kumar, S. Sivanagaraju, "Simualgion of D-Statcom and DVR in power system," ARPN jornal of engineering and applied science, vol.2, no. 3, pp. 7-13, June 2007.
- 15) Bor-Ren Lin, Senior Member, IEEE, Cheng-Chang Yang and Chien-Lan Huang "Series and Shunt Compensator for Power Quality Compensation", National Yunlin University of Science and Technology, 2006IEEE.
- 16) M. A. Hannan and Azad Mohamed, Member, IEEE, "Simulation of Unified Series -Shunt Compensator for Power Quality Improvement ",IEEE TRANSACTIONS ON POWER DELIVERY, VOL. 20, NO. 2, APRIL 2005.
- 17) W. Freitas, A. Morelato, "Comparative study between power system bolckset and PSCAD/EMTDC for transient analysis of custom power devices based on voltage source converter,"/PST, New Orleans, USA, 2003,PP. 1-6.
- 18) M. A. Hannan, A. Mohamed, A. Hussain and Majid al Dabbay, "Development of the Unified Series Shunt Copensator fof Power Quality Mitigation" American Journal of AppliedSciences 6(5): 978-986,2009
- 19) L Xu, O. Anaya- Lara, V. G. Agelidis, and E. Acha, "Development of prototype custom power devices for power quality enhancement," in Proc.9th ICHQP 2000, Orlando, FL, Oct 2000 ,pp.775-783.