

Performance and Evaluation of Voltage Source Inverter Feed Induction Motor Drive

Basanti Bhagat¹, Gurpreet Singh²

¹PG Scholar, Department of Electrical Engineering, V.E.C. Lakhanpur (c.g.) India.

^{2,3}Assistant professor Electrical Engineering, Dept. of Electrical Eng., V.E.C. Lakhanpur (c.g.) India.

Abstract:- This paper conclude speed control of induction motor the induction motor are use in the industrial drives because they are self starting, reliable and economical they use in the fix and variable speed. The voltage and frequency are varies speed are also varies. This present performance and evaluation of voltage source inverter feed induction motor drive. By varying stator terminal voltage from voltage source inverter. The model are PWM system use to vary voltage and frequency. PWM-Inverter fed 3-phase Induction Motor, and the Torque was found to be constant for various rotor speeds. PWM-Inverter fed 3-phase Induction Motor. It was observed that using a Closed-Loop scheme with a Proportional Controller gave a very superior way of controlling the speed of an Induction motor while maintaining a constant maximum torque. Simulation results are obtained using MATLAB/SIMULINK environment for the effectiveness of the study.

Keyword;- Voltage source inverter, PWM, Induction motor, Matlab simulink, Speed

I. Introduction

The induction motors were mainly used for essentially constant speed applications because of the unavailability of the system are variable – frequency voltage supply. The advancement of power electronics has made it possible to vary the frequency of the voltage supplies relatively easy, thus extending the use of the induction motor in variable speed drive applications. The power electronics are use in the more powerful of the other system. The System employed for the motion control is called a drive, if such system makes use of electrical motors then it is known as electrical drives. . In electrical drives, use of various sensors and control algorithms are done to control the speed of the motor using suitable speed control methods. The basic block diagram of an electrical drive is shown below in Fig .1

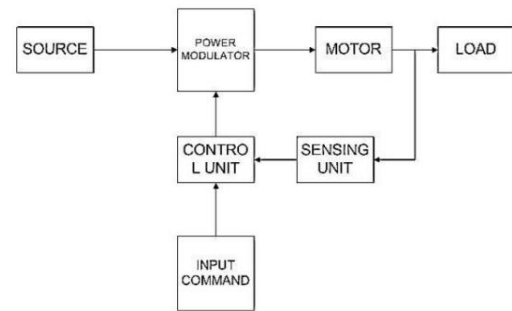

Fig:-1 Block diagram of electrical motor

A different type method of speed control techniques is available for the induction motor speed control. In this paper variable supply voltage control method is chosen due to its less complexity and cost-effectiveness. The block diagram are connected in different equipment it is used to speed control method, generate pulse width modulation, and convert voltage to use of inverter. The input system of the model are varies in input to required of the load and motor.

II. PROPOSED SYSTEM

In the proposed system single phase 220V, 50 Hz supply is used, which can be rectified into dc by using a diode full bridge rectifier. The output of the diode bridge rectifier contains large amount of ripples. In order to remove ripple, a capacitor filter is used here:

This ripple free dc is now provided as input to the voltage source inverter. Voltage source inverter is operated here in 180-degree conduction mode. The output of the voltage source inverter is three stepped waveforms of sinusoidal waves and of 120-degree phase shift with each other ,which is provided as input to the three phase induction motor. Three phase inverters, supplying voltages and currents of adjustable frequency and magnitude to the stator, are an important element of variable speed drive systems employing induction motors. Inverters with semiconductor power switches are DC to AC static power converters Depending on the type of DC source supplying the inverter. The proposed system is shown in Fig.2

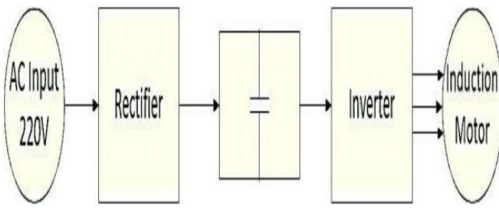

Fig:- 2 Proposed system

A.VSI OPERATION

Three phase inverters, supplying voltages and currents of adjustable frequency and magnitude to the stator, are an important element of variable speed drive systems employing induction motors. Inverters with semiconductor power switches are DC to AC static power converters. Depending on the type of DC source supplying the inverter, they can be classified as voltage source inverter (VSI) and current source inverter (CSI). In practice, the DC source is usually a rectifier, typically of the three phase bridge configuration, with DC link connected between the rectifier and inverter. The DC link is a simple inductive, capacitive, inductive-capacitive low-pass filter. Since neither the voltage across a capacitor nor the current through an inductor can change instantaneously. A capacitive output DC link is used for a VSI and an inductive-output link is employed in CSI. The voltages V_a , V_b , and V_c are the output voltages applied to the windings of a motor. S_1 through S_6 are the six power transistors which are controlled by a , a' , b , b' and c , c' gating signals and shape the output voltages. When an upper transistor is switched on, that is, when a , b , and c are 1, the corresponding lower transistor is switched off, that is, the corresponding a' , b' or c' is 0. The ON and OFF states of upper transistor S_1 , S_3 and S_5 , or the states to evaluate the output voltage. The structure of a typical three-phase voltage source inverter is shown in Figure 3

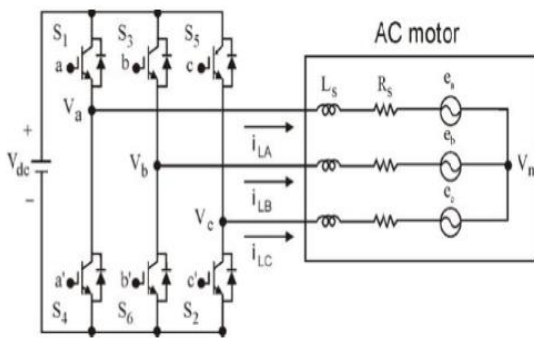

Fig:- 3 Three phase voltage source inverter with induction motor

VSIs can be either voltage or current controlled. In a voltage controlled inverter, it is the frequency and magnitude of the fundamental of the output voltage that is adjusted. Feed forward voltage control is employed, since the inverter voltage is dependent only on the supply voltage and the states of the inverter switches, and, therefore accurately predictable.

The voltage source inverter is a somewhat older design and less expensive to implement. Various implementation of the VSI are also known as six step, twelve -step, or even eighteen -step inverters. Voltage source inverter is operated in 180 degree conduction mode here, Each switch is operated for 180 degrees. No two switches in the same leg are operated simultaneously. At any time instant three switches are on in this mode. The gating signals and the resulting line voltages for stepped wave inverter in 180 degree conduction mode are shown in Figure .4

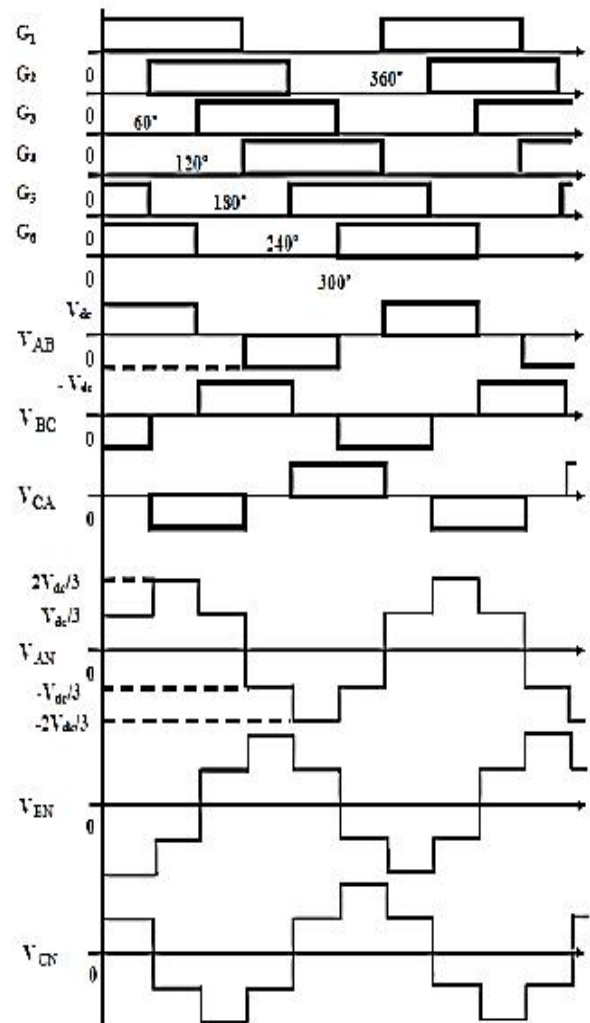

Fig: 4 Conduction of inverter

B. PULSE WIDTH MODULATION

In the voltage source inverter, the conversion of dc power to three phase ac power is performed in the switched mode. This mode consists of power semiconductor switches which are controlled in an on-off fashion. The actual power flow in each motor phase is controlled by the duty cycle of the respective switches. To obtain a suitable duty cycle for each switch, pulse width modulation is used. Many different methods were proposed and development of it is still in progress.

Wide range of linear operation.

Low content of higher harmonics in voltage and current.

Low frequency harmonics.

Operation in over modulation.

Reduction of common mode voltage.

III. SIMULATION STUDIES

Simulations are done using MATLAB/SIMULINK software tool for the analysis of speed control using voltage source inverter and performance of the system are observed with and without PI controllers in the system.

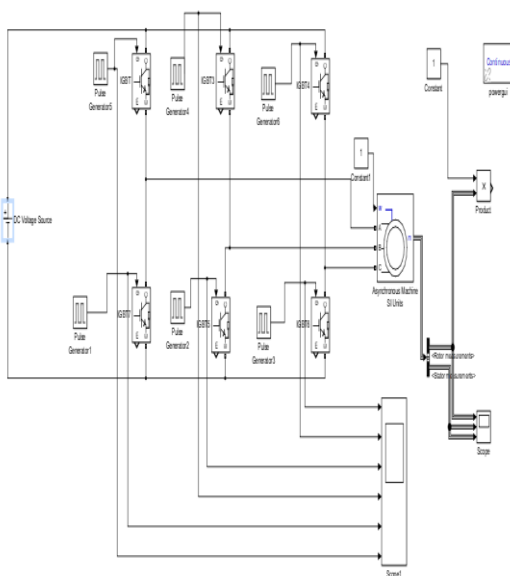

Fig : - 5 Block diagram of the system

The following figure shows the simulated diagram of the system.

Gating pulses for the switches are generated in such a manner that the output of the voltage source inverter

must have 3 phase sinusoidal waves with 120° phase shift between them. The model are speed control of induction motor drive are the variable frequency and voltage by the system.

IV. SIMULATION RESULTS

The simulation model is done in matlab simulation. The proposed model are speed control of induction motor by feed voltage source inverter method in the rating are increased by comparison of reference paper. In this paper are conclude by the speed rating increased and control of motor are very easily. The result is not to suitable in this paper in that region are mainly follows. The parameter of element are not apply proper value then our simulation model are not give suitable graph then we can apply the all parameter value are correct of element then the graph will correct, in simulation model.

V. CONCLUSION

Voltage source inverter fed induction motor drive is simulated. Voltage source inverter can be used to control the stator terminal voltage by controlling duty ratio of the switches. Hence stator terminal voltage is varied and results in speed variation of the motor. By properly controlling duty ratio desired speed range can be achieved in the motor.

VI. FUTURE SCOPE

The simulation of voltage source inverter fed three phase induction Motor Drive system is done using MATLAB/SIMULINK. The simulation can also be done using MATLAB. The hardware is implemented using micro controller. The hardware can also be implemented using DSP processor. Vector control or direct torque control may be implemented using DSP processor to control the speed of three phase induction motor drive.

REFERENCES

- 1) F. W. Fuchs, "Some diagnosis methods for voltage source inverters in variable speed drives with induction machines-A survey," in Proc. 29th Annu. Conf. IEEE Ind. Electron. Soc., Roanoke, VA, pp. 1378- 1385, Nov. 2003
- 2) R. A. Hanna and S. Prabhu, "Medium-voltage adjustable-speed drives users and manufactures experiences," IEEE Trans. Ind. Appl., vol. 33, no. 6, pp. 1407-1415, Nov./Dec. 1997.
- 3) Muhammed H Rahid,"Power electronics, circuits, devices and applications", Third edition, Pearson prentice hall, West florida, 2004.

- 4) Dr. P.S. Bimbhra, "Electrical Machinery", 7th Edition, Khanna Publishers, New Delhi, 2010.
- 5) M.C. Trigg and C.V. Nayar, "Matlab Simulink Modelling of a Single-Phase Voltage Controlled Voltage Source Inverter", Dept. of Electrical Engineering, Curtin University of Technology.
- 6) Scott Wade, Matthew W. Dunnigan, and Barry W. Williams, "Modelling and Simulation of Induction Machine Vector Control with Rotor Resistance Identification", IEEE transactions on power electronics, vol. 12, no. 3, may 1997.
- 7) P. S. Bimbhra, "Power Electronics", Third edition, Khanna publishers, Delhi, 2003.
- 8) F. Z. Peng, "Z-Source Inverter," IEEE transactions on industry applications, Vol. 39, No. 2, pp. 504-510, 2003
- 9) E. Fitzgerald, Charles Kingsley, Jr. And Stephan D. Umans, "Electrical Machinery", McGraw-Hills Publications, Year 2002.
- 10) Gopal K. Dubey, "Fundamentals of Electrical Drives", 2nd Edition, Narosa Publishing House, New Delhi, 2011.