

# IoT based Baby Incubator

Amullya Shinde<sup>1</sup>, Nikhil Patil<sup>2</sup>, Seema Patil<sup>3</sup>, Priyanka Gaikwad<sup>4</sup>, Vidya N.A<sup>5</sup>

<sup>1,2,3,4</sup>Student, Dept of Electronics & Telecommunication Engineering, SETI Panhala, Maharashtra, India

<sup>5</sup>Prof., Dept of Electronics & Telecommunication Engineering, SETI Panhala, Maharashtra, India

\*\*\*

**Abstract** - The neonatal incubator is an apparatus that provides a closed and controlled environment for the sustenance of premature babies. But recently, many premature babies have lost their lives due to lack of proper monitoring of the incubator that leads to accidents. This project deals with the design of an embedded device that monitors certain parameters such as pulse rate of the baby, temperature, humidity and light inside the incubator. The details are updated on the android app or web page of the hospital through IOT, so that proper actions can be taken in advance, to maintain the environment inside the incubator and ensure safety to the infant's life. So, the objective of this project is to overcome the above-mentioned drawbacks and provide a safe and affordable mechanism for monitoring the incubator.

**Key Words:** Internet of Things, neonatal incubator, parameter monitoring, temperature and humidity, pulse rate, light intensity

## 1. INTRODUCTION

A transport incubator is an incubator in a transportable form, and is used when a sick or premature baby is removed, e.g. from one hospital to another, as from a community hospital to a large medical facility with a proper neonatal intensive-care unit.

"In biology, an incubator is a device used to grow and maintain microbiological cultures or cell cultures. The incubator maintains optimal temperature, humidity and other conditions such as the carbon dioxide (CO<sub>2</sub>) and oxygen content of the atmosphere inside".

Premature babies, also known as preemies, are those that are born before the mother has reached 37 weeks of gestation. They are born too soon before certain key organs are able to develop. Depending on how premature the baby is, he or she may have an underdeveloped digestive tract, lungs, immune system, & even skin.

To help these babies survive outside of the womb, they will be placed in an apparatus known as an incubator which provides the newborn the environmental conditions needed to thrive while in the neonatal intensive care unit (NICU).

An incubator is a self-contained unit roughly the size of a standard crib equipped with a clear plastic dome. Because preemies lack body fat, they are less able to regulate

body temperature. To this end, the incubator ensures the ideal environmental conditions by either allowing the temperature to be adjusted manually or providing auto-adjustments based on changes in the baby's temperature.

But this is not its only function an incubator serves. An incubator also protects the preemie from infection, allergens, or excessive noise or light levels that can cause harm. It can regulate air humidity to maintain the integrity of the skin and even be equipped with special lights to treat neonatal jaundice common in newborns.

## 2. Block Diagram

The block diagram shows IOT Based Baby Incubator Circuit. It consists of following block:

- 1) Raspberry Pi
- 2) Temperature Sensor
- 3) Humidity Sensor
- 4) LCD
- 5) Power Supply
- 6) Output Devices, Cooler, Heater, etc

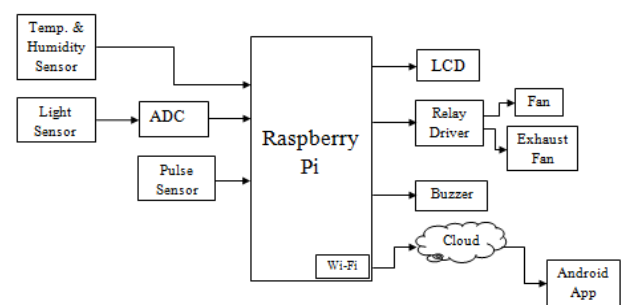

Fig -1: Block Diagram

### 2.1 Raspberry Pi:

The Raspberry Pi 3 Model B+ is the latest product in the Raspberry Pi 3 range, boasting a 64-bit quad core processor running at 1.4GHz, dual-band 2.4GHz and 5GHz wireless LAN, Bluetooth 4.2/BLE, faster Ethernet.

### 2.2 Temp. & Humidity Sensor:

Temperature & Humidity Sensor features a temperature & humidity sensor complex with a calibrated digital signal output. By using the exclusive digital-signal-acquisition

technique and temperature & humidity sensing technology, it ensures high reliability and long-term stability.

### 2.3 Heartbeat sensor:

The Pulse Sensor is a plug-and-play heart-rate sensor. It is an integrated optical amplifying circuit and noise eliminating circuit sensor. Clip the Pulse Sensor to earlobe or finger tip and plug it into RPi, & ready to read heart rate.

### 2.4 Light sensor:

A light-dependent resistor (LDR), or photocell is a resistor whose resistance will decrease when incident light intensity increase.

## 3. Working

In IOT Based Baby Incubator we used Raspberry Pi microcontroller Board. In this project the humidity sensor and temperature sensor i.e. DHT 11 sensor is input devices to sense the humidity and temperature. The Raspberry Pi, Relay driver circuit and the LCD is connected to each other in such manner. When the power supply is turned ON then the project name is display on LCD. Then the set button is pressed. The result is display on LCD i.e. "Set Temp From".

When the user is setting the temperature then the value of temperature is displayed on next row of LCD. After setting temperature now push set button second then LCD displays, "Set Temp End", then it again same as first set temperature.

Now push both set buttons to set all the temperature parameter. When both set button pressed then LCD shows the temperature humidity on first row and the heart beat on second row. Then the information of heartbeat and temperature is sending through Wi-Fi. The Wi-Fi is used to communicate the raspberry Pi and webpage/Android app, data is send to a particular webpage/Android app using the Wi-Fi.



## 4. CONCLUSIONS

The use of sensors supplement the IoT in the necessary applications.

IoT helps in sensing various objects, remote controlling of those objects and creates an ease in directly integrating the physical world into computer-based systems.

This results in improved efficiency and accuracy and in economic benefit.

## REFERENCES

- [1] Microcontroller Based Baby Incubator Using Sensors, M.Suruthi, S.Suma, International Journal of Innovative Research in Science, Engineering and Technology, Vol. 4, Issue 12, December 2015, ISSN 2319-8753.
- [2] PIC Microcontroller based Efficient Baby Incubator, International Journal of Advanced Research in Electrical, Electronics and Instrumentation Engineering, Vol. 4, Issue 2, February 2015, ISSN
- [3] A Wireless Based Temperature, Humidity and Light Intensity Monitoring System for Child Incubators, Mr. Mamun, ISSN: 2393-9516, International Journal of Engineering Trends and Applications (IJETA) – Volume 2 Issue3, May- June 2015