

# Live Health Care Monitoring System using Arduino

B. Sarathkumar<sup>1</sup>, D. Periyazhagar<sup>2</sup>, S. Sivasakthi<sup>3</sup>

<sup>1</sup>PG Student, Dept. of Electrical and Electronics Engineering, Krishnasamy College of Engineering and Technology, Tamil Nadu, India.

<sup>2</sup>Assistant Professor, Dept. of Electrical and Electronics Engineering, Krishnasamy College of Engineering and Technology, Tamil Nadu, India.

<sup>3</sup>Associate Professor and Head of the Department, Dept. of Electrical and Electronics Engineering, Krishnasamy College of Engineering and Technology, Tamil Nadu, India.

\*\*\*

**Abstract:-** Innovative technology approaches have been increasingly investigated for the last two decades aiming at human-being long-term monitoring. The main aim of this paper is to supervise the patients affected from chronic diseases, blood pressure and the elderly people at their home itself with an android application. By doing this, unwanted visit to the hospital can be avoided. The system was developed to supervise the vital signs such as temperature, blood pressure, heart rate, gas sensor and fall detection. The system design consists of an Arduino controller and GSM900A module. The monitored values can be sent through the mobile phones and if it detects abnormal state then it enables the buzzer and the information is passed to the concerned members through the mobile application. In case of regular check up there is no need for the patient to go and meet the doctor or physician with the proposed system. The patient can send an SMS as CHECK to test the body condition to detect the health condition of the patient from the ECG signal. The system will also transmit the data of healthcare information to the concerned doctor's mobile phone through app.

**Key Words:** Healthcare Monitoring, GSM/Global Positioning System, ECG signal and Fall detection...

## 1. INTRODUCTION

This is a fact that the global population is both growing and ageing. As a consequence of this demographic change, there has also been a corresponding increase in chronic age related diseases, such as congestive heart failure, dementia, sleep apnea, cancer, diabetes, and chronic obstructive pulmonary diseases. Furthermore, the total number of people suffering from some type of disability (either life-long, or injury related, or more commonly related to chronic conditions) will continue to rise.

Nowadays, the requirement for healthcare system development is rigorously increasing. In the past, consumer used to see doctor whenever they found problems of their health status. However, prevention is much more efficient than curing. Advanced technology can help to check their health status as well as providing location services wherever instant health problems happened. In recent years, there has been a tremendous change in the healthcare system considering the both convenience and efficiency which

allows consumer to instantly locate the position of patient who has instant problem health problem.

It is important for patients that healthcare practitioners cooperate closely and efficiently in the chain. This is especially critical when caring for and treating the chronically ill. The complexity of healthcare lies in making the correct diagnosis and avoiding duplicate analysis. The right tests and examinations should be carried out, and information should be shared among all the relevant healthcare practitioners. This means both professional information and information about the patient, his or her illness, past and future treatment and medication. It has often been said that we need coordinators in healthcare to link all the parties to one another and organize things from the patient's perspective. The candidate mentioned most frequently for this task is the general practitioner, who already bears overall final responsibility in many healthcare systems; otherwise, there is a risk of duplication, which only makes matters more complicated rather than simpler. Of course, general practitioners do not monitor patients every single day.

## 2. RELATED WORKS

This section present the most related research approach and techniques based on healthcare monitoring devices for elderly.

Nikolaos G. Bourbakis et al [1] This paper attempts to comprehensively review the current research and development on wearable biosensor systems for health monitoring. A variety of system implementations are compared in an approach to identify the technological shortcomings of the current state-of-the-art in wearable biosensor solutions. Y.Ravi Sekhar Maradugu Anil Kumar [2] The health care scheme is focus on the measurement and Monitoring various biological parameters of patient's body like heart rate, oxygen saturation level in blood and temperature using a web server and android application, where doctor can continuously monitor the patient's condition on his smart phone using an Android application. The functioning of the intelligent system developed by Wang et al. [4] is mainly based on the collected blood pressure and pulse signals from the patients for the functioning of the heart automatically. The authors tested and experimented

this with a simulation model. An emergency healthcare system is developed by Kang et al. [5] which is a ubiquitous integrated biotelemetry system. This is also an automated system and it gives a quick treatment for the patients once they arrive to the hospital. Because, all the primary data's like blood pressure, pulse rate etc., are all prerecorded and sent to the hospital prior to the patient's arrival through a wearable device. The ultrasonic graph and skin image of the patient can also be recorded with this system.

The system proposed by Vaidehi et al. [6] utilized a camera to monitor the patient's activity inside the room. The main drawback with this is that it can estimate if the patient stays in that room for a long period of time. Hsieh et al. [7] come up with a wrist-worn motion-sensing device to detect falling events; the sensing device consists of a tri-axis accelerometer and a three-axis gyroscope. The disadvantage with this is that it does not detect the location of falling objects. Wang et al. [8] proposed an enhanced fall detection system based on a smart sensor worn on the body for elderly people to monitor and operate monthly once by sitting at home. Bai et al. [9] utilized the accelerometer of a smart phone to design and implement a GPS based monitoring system for the user. The system concentrated on analyzing the six typical actions of humans in addition to the change of acceleration.

WahChing Lee et al (2016) [11] Calibrated Fuzzy C-Means Clustering Algorithm (C-FCM) is proposed in this investigation based on received signal strength (RSS) in wearable device. A wireless technology is adopted to provide an efficient localization monitoring system for patients or the elderly in indoor area. The location of patients can be obtained through the developed algorithm. Torkestani et al (2012) [10] concentrated on Wireless Personal Area Networks (WPAN) from small and low-power digital radios. The low power consumption features of ZigBee network have not become one of its limitations in data transmissions. This network usually enables devices to achieve the data transmission over almost 100 meters despite its low-powered characteristics. In the network, each device can communicate directly with other devices or communicates with other devices through neighbor devices in the network.

Wang et al. 2013 [13] proposed a health care kit with controller and processing unit. Each sensor produces an electrical signal, and this electrical signal is converted into digital form. The data generated by the sensor is raw information. This raw information needs to be processed further to perform certain essential actions. These actions are a direct function of the programming and configuration logic that implements in the processor. Different levels of intelligence can be designed and performed based on personalized requirement

Zhang et al.[14] proposed a role-based approach for the body area network using clean state architecture. The communication logic of Zhang's work implemented through

the role of individual instead of using protocol layer model directly. Most of the roles were interdependent; the functioning of one is defined by the other. Zhang explored packet processing for the internal state by new rules and algorithm. The work of Zhang was a very initial step onwards the role-based Approach.

Zhen et al. (2007) [03] concluded that it is very critical to predict the Clear Channel Assessment (CCA) between ZigBee and Wi-Fi. The author identified the Wi-Fi is insensitive towards ZigBee. However ZigBee is oversensitive to Wi-Fi. Thus CCA range for coexistence behavior was 25 m with free space path loss model. Tytgat et al. (2012) [12] presented that the Activity Recognition algorithms and approaches - CCA range of ZigBee can cut down the collisions with Wi-Fi. But it is noticed that the Wi-Fi channel traffic is much more than ZigBee CCA mechanism. They logged up to 85% ZigBee packet loss rate due to 802.11b contention.

Rodrigues et al (2012) [15] proposed new modular platform including the role of body area network coordinator. Advanced sensors are the sensors which are more than the ambient sensing and to look after the particular need of individuals such as emotion and impact sensor. For a context-aware scenario, it is necessary that it should identify the mood of the occupant, for instance, heart rate sensor discovers the pressure and generates medicine reminder as well as inform the caregiver as desired.

### 3. PROPOSED METHODOLOGY

This paper proposed a methodology based on health monitoring that overcomes the above mention disadvantages. This project is designed to reduce the work of visiting the hospital for usual checkup for the patients. To protect the ill patients & aged persons by embedded system based real time patient distance monitoring system using GSM/GPS technologies. Sensors such as temperature, gas, fall detection, heart rate and blood pressure rate adopted in this work to effectively maintain the proposed health monitoring system. A monitoring system, specifically designed for cardiac care with electrocardiogram (ECG) signal analysis as the core diagnostic technique, could play a vital role in early detection of a wide range of cardiac ailments, from a simple arrhythmia to life threatening conditions such as myocardial infarction. The system that have developed consists of three major components, namely, (a) mobile gateway, deployed on patient's mobile device, that receives 12-lead ECG signals from any ECG sensor, (b) remote server component that hosts algorithms for accurate annotation and analysis of the ECG signal and (c) point of care device of the doctor to receive a diagnostic report from the server based on the analysis of ECG signals. The focus has been toward developing a system capable of detecting critical cardiac events well in advance using an advanced remote monitoring system. A system of this kind is expected to have applications ranging from tracking wellness/fitness to detection of symptoms leading to fatal cardiac events Vital

signs are measurements of the body's most basic functions. The main vital signs routinely measured by health care unit and doctors are:

- Body temperature
- Pulse rate
- Respiration rate (rate of breathing)
- Blood pressure

(The Blood pressure is not considered a vital sign, but is often measured along with the vital signs.)

Vital signs are used to detect and monitor medical problems. In this system temperature, pulse rate, ECG is considered. The body temperature of a person normally varies depending on gender, recent activity, food and fluid consumption, time of day, and, in women, the stage of the menstrual cycle. For a healthy adult the normal body temperature can range from 97.8 degrees Fahrenheit (36.5 degrees Celsius) to 99 degrees Fahrenheit (37.2 degrees Celsius).

The pulse rate is a measure of number of times the heart beats per minute and the heart rate. The arteries expand and contract when heart pushes blood through arteries. The pulse measured only measures the heart rate, but also can represent the Heart rhythm and Pulse strength.

The normal pulse value for the healthy adults ranges from 60 to 100 beats per minute. During exercise, illness, injury, and emotions the pulse rate may fluctuate and increase. Than males, 12 age and older females tend to have faster heart rates. Athletes, such as runners, may have heart rates near 40 beats per minute due to cardiovascular conditioning and experience no problems. According to the National Heart, Lung, and Blood Institute (NHLBI) the high blood pressure for adults is given as

- 140 mm Hg or greater systolic pressure
- 90 mm Hg or greater diastolic pressure

In an update of NHLBI guidelines in 2003 for hypertension, a category of new blood pressure called pre hypertension

- 120 mm Hg – 139 mm Hg systolic pressure
- 80 mm Hg – 89 mm Hg diastolic pressure

The NHLBI guidelines define normal blood pressure as follows

- Below 120 mm Hg systolic pressure
- Below 80 mm Hg diastolic pressure

### 3.1 BLOCK DIAGRAM DESCRIPTION

The following diagram shown in Figure 1 is the block diagram of the proposed system.

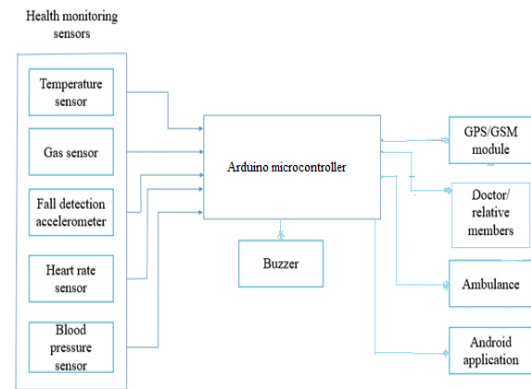

Figure 1. Block Diagram of the Proposed System

### 3.2 TEMPERATURE SENSOR

The body temperature is measured by using the temperature sensor LM35. It is a three terminal device. Pin number one is 5 volt voltage supply and three are for ground. Pin two is analog voltage output with respect to temperature. There is no need of extra circuitry to operate it. Arduino UNO microcontroller is used to read temperature value. The Relation between the temperature and analog output voltage is:

$$10\text{mC} = 10\text{m volt} \tag{1}$$

Hence for every 1 degree increase in temperature there will be an increment of 10m volt in output voltage of LM35 sensor. The output of sensor is given to analog channel of Arduino UNO. Now after reading ADC value, using voltage and temperature relationship voltage is converted into temperature. These conversions have been done through programming.

The LM35 series are precision integrated circuit temperature sensors, with an output voltage linearly proportional to the temperature (centigrade) which is advantageous over the sensors that measures the temperature in Kelvin. By using this, the user need not have to go for temperature conversion.

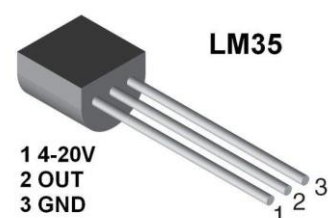

Figure 2. LM35

One more advantage with this sensor is it does not need any external calibration or trimming to provide typical accuracies of  $\pm \frac{1}{4}^{\circ}\text{C}$  at room temperature and  $\pm \frac{3}{4}^{\circ}\text{C}$  over a full  $-55^{\circ}\text{C}$  to  $150^{\circ}\text{C}$  temperature range. Due to the trimming and calibration at the wafer level, it costs very less. With the features of low output impedance, linear output, and precise inherent calibration of the device, the interfacing with readout or control circuitry becomes easy. The device can work with plus or minus single power supplies. Because of its very low self-heating of less than  $0.1^{\circ}\text{C}$  in still air, it takes only a  $60\mu\text{A}$  from the supply. The temperature range is from  $-55^{\circ}\text{C}$  to  $150^{\circ}\text{C}$ . The temperature sensing element present in this is a deltaV BE architecture.

### 3.3 HEART BEAT SENSOR

The new version uses the **TCRT1000** reflective optical sensor for photo plethysmography. The use of TCRT100 simplifies the build process of the sensor part of the project as both the infrared light emitter diode and the radar are arranged side by side in a leaded package, thus blocking the surrounding ambient light, which could otherwise affect the sensor performance. I have also designed a printed circuit board for it, which carries both sensor and signal program unit and its output is a digital pulse which is synchronous with the heartbeat. The output pulse can be fed to either an ADC channel or a digital input pin of a microcontroller for another processing and retrieving the heart rate in beats per minute (BPM). The project is based on the principle of photoplethysmography (PPG) which is a non-invasive method of leveling the variation in blood body in tissues using a light source and a detector. Since the change in blood volume is synchronous to the heart beat, this capacity can be used to calculate the heart rate. Transmittance and reflectance are two basic types of photo plethysmography. For the transfer PPG, a light source is emitted in to the material and a light detector is placed in the opposite side of the tissue to measure the resultant light. Because of the limited penetration depth of the light through organ tissue, the transmittance PPG is applicable to a reduced body part, such as the finger or the ear lobe. However, in the reflectance PPG, the light source and the bright detector are both placed on the same side of a body part. The light is emitted into the tissue and the reflected light is measured by the detector. As the light doesn't have to penetrate the body, the reflectance PPG can be activated to any parts of human body. In either case, the detected light repeated from or transmitted through the body part will fluctuate according to the pulsatile blood flow caused by the beating of the heart.



Figure 3. Heart Beat Sensor

### 3.4 ARDUINO UNO

An Arduino board consists of an Atmel 8, 16 or 32 bit with an AVR microcontroller which can be programmed and incorporated into other circuits. It consists of standard connectors, which connect the CPU board to a variety of interchangeable add-on program shields. The communication between the shields and the Arduino board can be done directly over various pins or the shields are individually addressable via an I<sup>2</sup>C serial bus. It is possible to use it in parallel by stacking many shields. The boards may contain 5v linear regulator and a 16 MHz crystal oscillator (or ceramic resonator in some variants). Some other boards like LilyPad run at 8 MHz with an onboard voltage regulator. This Arduino's microcontroller can be pre-programmed and with the help of a boot loader, it can be uploaded to the on-chip radiation memory. It can be noticed that the other devices charge with the help of an external programmer. Based on all these features, it is decided to choose Arduino as our prime microcontroller for our design.

Arduino boards are programmable and its implementation lies with the hardware translation. Most of the Arduino boards consist of a constant shifter circuit to switch over between RS 232 and transistor transistor logic (TTL) level signals. Nowadays, Universal Serial Bus (USB) are used to program the Arduino boards with the help of USB-to-serial adapter chips such as the FTDI FT232. Later-model Uno boards replaces the FTDI chip with a isolated AVR chip which has a USB-to-serial firmware and these are programmed by means of its own ICSP header. Many other boards such as the Arduino Mini and the unofficial Boarduino are available in the market that makes use of the USB-to-serial adapter board or cable, Bluetooth or other methods. A new method called, AVR in-system programming (ISP) is found suitable with traditional microcontroller tools rather of the Arduino IDE, standard.

### 3.5 BLOOD PRESSURE SENSOR

The BMP180 is the next-generation of sensors from Bosch, and replaces the BMP085. The good news is that it is completely identical to the BMP085 in terms of firmware/software - you can use our BMP085 tutorial and any example code/libraries as a bit-in replacement. The XCLR pin is not physically present on the BMP180 so if you need to know that data is ready you will need to query the I<sup>2</sup>C bus. This board is 5V compliant - a 3.3V regulator and a I2C level shifter circuit S included so you can use this sensor safely with 5V logic and power.

- Vin: 3 to 5VDC
- Logic: 3 to 5V compliant
- load sensing range: 300-1100 hPa (9000m to -500m above sea level)



- Up to 0.03hPa / 0.25m resolution
- 40 to +85°C operational range, +2°C temperature accuracy
- This board/chip uses I2C 7-bit address 0x77.

### 3.6 GAS SENSOR

Sensitive material of MQ-6 gas sensor is SnO<sub>2</sub>, which has lower conductivity in clean air. As the concentration of the gas is rising, sensor's conductivity is also becoming high. It is very sensitive to Propane, Butane and LPG, also it responds to Natural gas. Mostly, the gas sensor is widely used to find different combustible gas, particularly Methane. It is mainly used because of its low cost and suitability to different application. This sensor composed of micro AL<sub>2</sub>O<sub>3</sub> ceramic tube, Tin Dioxide (SnO<sub>2</sub>) sensitive layer, measuring electrode and heater are fixed into a layer made by plastic and stainless steel net. The main function of the heater is to provide a suitable state for the working of sensitive components. The MQ-4 sensor consists of 6 pins, out of which, 4 of them are mainly to retrieve the signals, and others are used for providing heating current.

### 3.7 ADXL345

The ADXL345 is a small, thin, low power, 3-axis accelerometer with high resolution (13-bit) measurement at up to + or - 16 g. Digital output data is formatted as 16-bit twos complement and is accessible through either a SPI (3- or 4-wire) or I2C digital interface. The ADXL345 is well suited for mobile material applications. The static acceleration of gravity in tilt-sensing applications, and the dynamic acceleration resulting from motion or shock can be measured with this. Its high resolution (4 mg/LSB) enables measurement of inclination changes less than 1.0°.

Several special sensing functions are provided. Activity and inactivity sensing detect the presence or loss of motion and if the acceleration on any axis exceeds a user-set level. Tap sensing detects single and double taps. Free-fall sensing detects if the creation is falling. These functions can be mapped to one of two interrupt output pins. An integrated, patent pending 32-level first in, first out (FIFO) defence can be used to store data to minimize host processor intervention. Low power modes enable intelligent motion-based power management with threshold sensing and active acceleration measurement at extremely low power dissipation.

### 3.8 GSM

GSM/GPRS engine SIM900A, works on frequencies 900/1800 MHz. The Modem is coming with RS232 interface, which allows you connect PC along with microcontroller among RS232 Chip (MAX232). The baud rate is configurable from 9600-115200 through AT command. The GSM/GPRS Modem include internal TCP/IP stack to connect with

internet via GPRS. It is suitable for SMS, Voice as well as DATA transfer application in M2M interface.

The onboard Regulated Power supply allows to connect wide range uncontrolled power supply. This GSM Modem can accept any GSM network operator SIM card and act just like a mobile phone with its own unique phone number. Advantage of using this modem is that its RS232 port can communicate and establish embedded applications. The modem can be connected to PC serial port directly or to any microcontroller through MAX232. It can be used to send and receive SMS or make/receive voice calls. It can also be used in GPRS mode to connect to internet and do many applications for data logging and control. This GSM modem is a deeply flexible plug and play quad band SIM900A GSM modem for direct and easy integration to RS232 applications. Supports features like Voice, SMS, Data/Fax, GPRS and integrated TCP/IP stack.

## 4. SIMULATION RESULTS

The Arduino Uno is the heart of the whole system that program is loaded and compiled to run. The output is verified using the virtual terminal window. Virtual Terminal is a tool in Proteus, which is used to view data coming from Serial Port (DB9) and also used to send the data to Serial Port. The following Figure 4 shows the simulated results of the proposed system using Proteus 8.1.

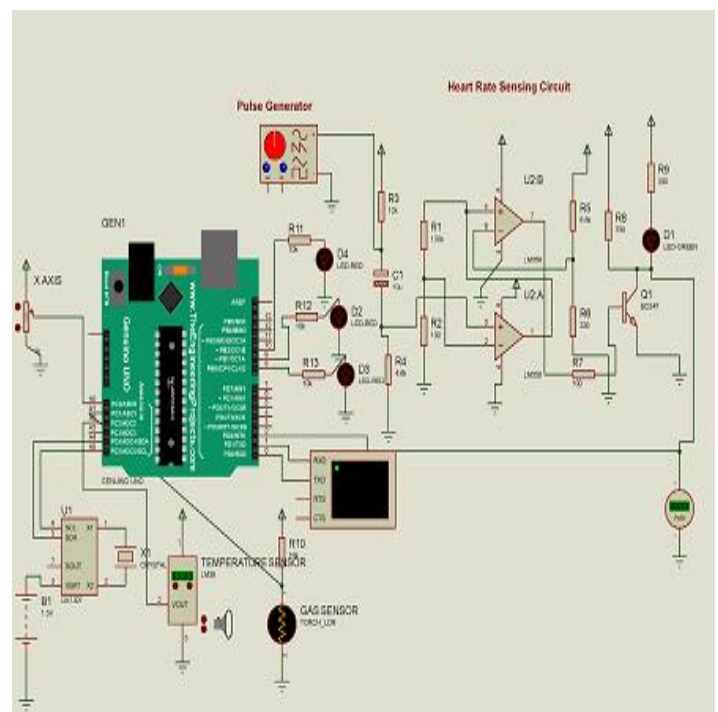
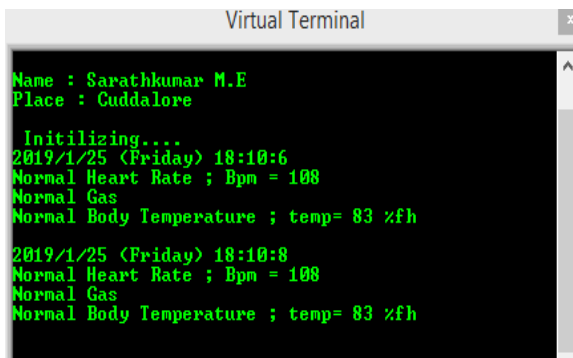

Figure 4. Simulation results



```

Virtual Terminal
Name : Sarathkumar M.E
Place : Cuddalore

  Initializing...
2019/1/25 (Friday) 18:10:6
Normal Heart Rate ; Bpm = 108
Normal Gas
Normal Body Temperature ; temp= 83 %fh

2019/1/25 (Friday) 18:10:8
Normal Heart Rate ; Bpm = 108
Normal Gas
Normal Body Temperature ; temp= 83 %fh
    
```

Figure 5. Normal values of vital sign

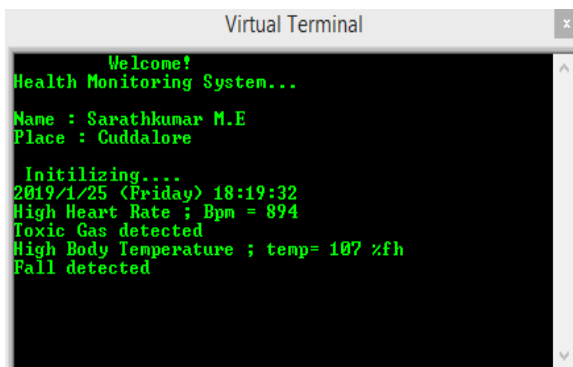

```

Virtual Terminal
Welcome!
Health Monitoring System...

Name : Sarathkumar M.E
Place : Cuddalore

  Initializing...
2019/1/25 (Friday) 18:19:32
High Heart Rate ; Bpm = 894
Toxic Gas detected
High Body Temperature ; temp= 107 %fh
Fall detected
    
```

Figure 6. Abnormal values of vital sign

## 5. CONCLUSION

The outdoor health monitoring system which is effectively used in real time medical applications is developed here. This system monitors the vital signs of the patient in the home and there is no need to visit hospital often. It uses the ARDUNIO UNO controller to receive input and transmit to external devices. It uses the GSM 900A modem which transmits the messages and when it receives the text as check it automatically monitors the respective parameters to transfer. This system is designed to reduce the work and it can be implemented with the low cost and for the daily usage to save life in emergency condition. The simulation for the whole model is designed and tested using Proteus 8.1.

## REFERENCE

1. Alexandros Pantelopoulos and Nikolaos G. Bourbakis, Fellow. "A Survey on Wearable Sensor-Based Systems for Health Monitoring and Prognosis", *ieee vu university amsterdam applications and reviews*, vol. 40, no. 1, january (2010).
2. Maradugu Anil Kumar, Y.Ravi Sekhar. "Android Based Health Care Monitoring System" *IEEE Sponsored 2nd International Conference on Innovations in Information, Embedded and Communication systems (ICIIECS) 2015*.

3. Zhen, H.-B. Li, S. Hara, and R. Kohno, "Clear channel assessment in integrated medical environments," *EURASIP Journal on Wireless Communications and Networking*, vol. 2008, pp. 1–8, 2007.
4. C. H. Wang, M. F. Horng, J. W. Lee, Y. C. Liu, R. S. Tsai, W. T. Wang, L. Chang, Y. H. Kuo, P. C. Chung, and K. F. Ssu, "Development of Intelligent Home Health-Care Box Connecting Medical Equipment and Its Service Platform," in *Proc. The 9th Int. Conference on Advanced Communication Technology*, pp. 311-315, Feb. 2007.
5. J. Kang, I. H. Shin, Y. Koo, M. Y. Jung, G. J. Suh, and H. C. Kim, "HSDPA (3.5G)-Based Ubiquitous Integrated Biotelemetry System for Emergency Care," in *Proc. 2007 29th Annual Int. Conference of the IEEE Engineering in Medicine and Biology Society*, pp. 3665-3668, Aug. 2007.
6. V. Vaidehi., K. Ganapathy, K. Mohan, A. Aldrin, and K. Nirmal, " Video based automatic fall detection in indoor environment," in *Proc. 2011 Int. Conference on Recent Trends in Information Technology (ICRTIT)*, pp. 1016-1020, Jun. 2011.
7. S. L. Hsieh, C. C. Chen, S. H. Wu, and T. W. Yue, "A wrist -worn fall detection system using accelerometers and gyroscopes," in *Proc. 2014 IEEE 11th Int. Conference on Networking, Sensing and Control (ICNSC)*, pp. 518-523, Apr. 2014.
8. J. Wang, Z. Zhang, B. Li, S. Lee, and R. Sherratt "An enhanced fall detection system for elderly person monitoring using consumer home networks," *IEEE Trans. Consumer Electronics*, vol. 60, no. 1, pp. 23-29, Feb. 2014.
9. Y. W. Bai, S. C. Wu, and C. L. Tsai, "Design and implementation of a fall monitor system by using a 3-axis accelerometer in a smart phone," in *Proc. IEEE 16th Int. Symp. Consumer Electronics (ISCE)*, pp. 1-6, Jun. 2012.
10. S.S. Torkestani, S. Sahuguede, A. Julien-Vergonjanne, J.P. Cances, "Indoor optical wireless system dedicated to healthcare application in a hospital," in *Communications, IET*, vol.6, pp.541-547, March 27 2012.
11. Lee, WahChing, FaanHei Hung, Kim Fung Tsang, Chung Kit Wu, and Hao Ran Chi. "RSS-based Localization Algorithm for Indoor Patient Tracking."
12. Zhen, H.-B. Li, S. Hara, and R. Kohno, "Clear channel assessment in integrated medical environments," *EURASIP Journal on Wireless Communications and Networking*, vol. 2008, pp. 1–8, 2007.

13. M. Wang, G. Zhang, C. Zhang, J. Zhang, and C. Li, "An IoT-based appliance control system for smart homes," in Intelligent Control and Information Processing (IC ICIP), 2013 Fourth International Conference on, Beijing, 9-11 June 2013, pp. 744-747.
14. L. Zhang, G.-J. Ahn, and B.-T. Chu, "A role-based delegation framework for healthcare information systems," in Proceedings of the seventh ACM symposium on Access control models and technologies, Monterey, California, USA, June 3-4, 2002, pp. 125-134.
15. A. Rodrigues, T. Camilo, J. Sa Silva, F. Boavida, M. Silva, N. Blanco, et al., "Hermes: A versatile platform for wireless embedded systems," in World of Wireless, Mobile and Multimedia Networks (WoWMoM), 2012 IEEE International Symposium on a, San Francisco, CA, 25-28 June, 2012, pp. 1-9.