

# DESIGN OF RACK AND PINION STEERING FOR ALL TERRAIN VEHICLE

Ajay M. Tayde<sup>1</sup>, Sanket P. Golhar<sup>2</sup>, Shital R. Ughade<sup>3</sup>, Nikita Ramdas Kakde<sup>4</sup>

<sup>1,2,3,4</sup>Student, Department of Mechanical Engineering, PRMIT&R, Badnera, Amravati University, Maharashtra (INDIA)

**Abstract:** Aim is to design a Rack and Pinion Gearbox (RPG) which has desired steering ratio, zero play in the Rack and pinion gear box and sensitive steering. Rack and pinion steering systems are commonly used due to their simplicity in construction and compactness. Main purpose of this paper is to design the rack and pinion steering system. In this paper analyzed the two components of the steering system. In order to calculate the stresses, safety factor, no of teeth on rack and pinion. Improve the performance of steering system.

**Key words:** Rack and pinion, teeth, addendum, Dedendum, pitch circle

## 1. Introduction

The function of the steering system is to provide directional control to the vehicle. For this a gearbox is used which converts rotational motion of steering wheel into translational motion of tie rod which in turn rotates the tires. There are different types of gear box but mostly in All Terrain Vehicle (ATV) the rack and pinion gearbox.

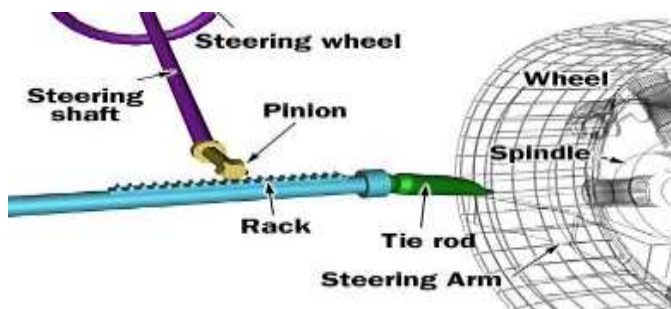

Fig-1: Steering system

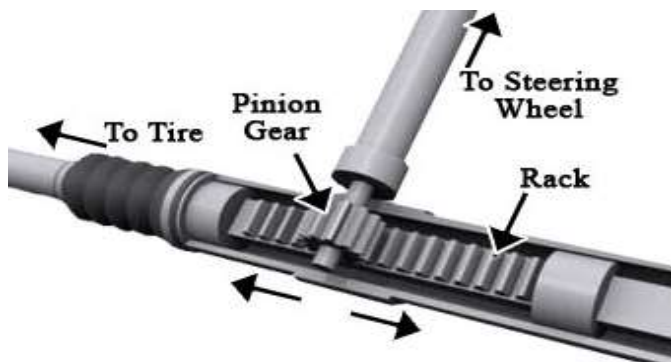

Fig-2: Rack and Pinion

Above fig. shows the Rack and pinion steering is a simple system that directly converts the rotation of the steering wheel to straight line movement at the wheels. The steering gear consists of the rack, pinion, and related housings and support bearings. Turning the steering wheel causes the pinion to rotate.

## 1.1 Requirements of steering system

- 1) Provide the proper turning to vehicle on sharp edges of track.
- 2) Require minimum effort to turn the vehicle.
- 3) Design in such a way that minimum shock will be acts on driver.
- 4) Loss of steering wheel control should not occur.
- 5) Steering system recovery should be smoothly, after removing the forces by drive it should come at straight position smoothly.

## 2. Steering Geometry

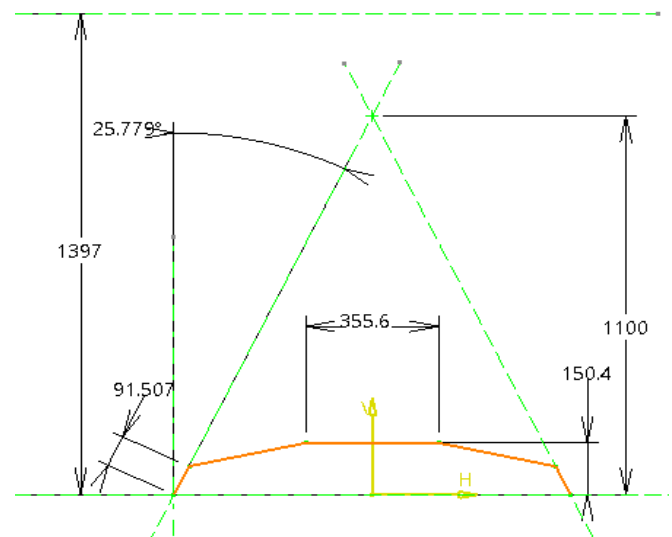

Table-1: Steering Design Consideration:

Parameters	Values
Wheel Base	55in or 1397mm
Track Width	51in or 1295mm
Castor Angle	4°
Inner Locking Angle	46°

Material used: Al T6 7075  
 Mostly in ATV the rack and pinion steering is made up of Al T6 7075 which having and desired physical properties.

**Table-2:** Physical Properties

Parameters	Values
Density	2810kg/m <sup>3</sup>
Hardness	BHN = 150
Ultimate Tensile Strength	541MPa
Yield Strength	468GPa
Modulus of Elasticity	71.7GPa
Poisson's Ration	0.33

Generally the modulus is given by the manufacturers hence considering the modulus as 2.5

### 3. For calculating the Turning Radius

For Perfect Ackerman

$$\cot(\text{outer angle}) - \cot(\text{inner angle}) = \frac{\text{Track width}}{\text{Wheel base}}$$

$$\cot \alpha - \cot = \frac{b}{l}$$

$$\cot \alpha = \frac{1295}{1397} + \cot (46)$$

$$\text{Therefore } \alpha = 27.84^\circ$$

$$\begin{aligned} \text{Inside Turning Radius (R}_i) &= \frac{1}{\sin \beta} \\ &= \frac{1397}{\sin(46)} \\ &= 1942\text{mm} \end{aligned}$$

$$\begin{aligned} \text{Outside Turning Radius (R}_o) &= \frac{1}{\sin \alpha} \\ &= \frac{1397}{\sin(27.84)} \\ &= 2291\text{mm} \end{aligned}$$

$$\begin{aligned} \text{Turning Radius} &= \frac{(1942+2291)}{2} \\ &= 2116\text{mm} = 2.116\text{m} \end{aligned}$$

**Table-3:** Gear Considering Parameters

Parameters	Values
Pressure angle ( $\phi$ )	20°
Module	m
Addendum	m
Dedendum	1.25m
Clearance	0.25m
Working depth	2m
Whole depth	2.25m
Tooth thickness	1.5708m

### 4. Minimum Number of Teeth on Pinion

Minimum number of teeth on pinion is obtained by using following relation.

$$T_p = \frac{(2 * \text{Addendum})}{\text{module} * \sin^2(\text{Pressure angle})} = \frac{2 * m}{m * \sin^2(20)} = 17$$

### 5. Design of gear pair

It is necessary to design rack and pinion such a way that it must provide required torque for turning the vehicle.

#### 5.1 Beam Strength

Beam strength of gear tooth is the maximum tangential load that gear tooth can take without tooth damage.

Assumptions:

- 1) The full load is acting at the tip of a single tooth.
- 2) The effect of radial force is neglected.
- 3) The load is uniformly distributed across the full face width.
- 4) Effect of stress concentration is neglected.
- 5) Frictional force due to teeth sliding are neglected.

#### 5.2 Calculations

##### 5.2.1 Bending endurance strength of pinion ( $\sigma_{bp}$ ):

Beam strength of gear tooth is the maximum tangential load that gear tooth can take without tooth damages.

$$\sigma_{bp} = \frac{\text{Ultimate tensile strength}}{3} = \frac{541}{3} = 180.33\text{MPa}$$

##### 5.2.2 Bending endurance strength of gear ( $\sigma_{bg}$ ):

$$\sigma_{br} = \frac{\text{Ultimate tensile strength}}{3} = \frac{541}{3} = 180.33\text{MPa}$$

##### 5.2.3 Lewis form factor (Y):

$$1) Y_p = 0.484 - \frac{2.87}{\text{Teeth on pinion}} = 0.484 - \frac{2.87}{17} = 0.311$$

$$2) Y_r = 0.484 - \frac{2.87}{\text{teeth on rack}} = 0.484 - \frac{2.87}{27} = 0.377$$

$$\sigma_{bp} * Y_p = 180.33 * 0.311 = 56.08$$

$$\sigma_{br} * Y_r = 180.33 * 0.377 = 67.98$$

$$\sigma_{bp} * Y_p < \sigma_{br} * Y_r$$

Pinion is weaker than rack in bending. Hence it is necessary to design the pinion for bending.

Assuming  $b = 10 * m$ ,

The beam strength is given by,

$$P_b = \sigma_{bp} * b * m * Y_p$$

$$P_b = 180.33 \cdot 10^3 \cdot m^3 \cdot 0.311$$

$$P_b = 560.82 \text{ m}^2 \text{ N}$$

#### 5.2.4 Wear strength

The failure of the gear tooth due to pitting occurs when the contact stresses between two meshing teeth exceed the surface endurance strength of the material.

Buckingham's theory is based on hertz theory of contact stresses. From his theory we can conclude that Wear strength of a gear tooth is the maximum tangential load the gear tooth can take without causing a pitting failure.

$$P_w = b \cdot Q \cdot d_p \cdot k$$

$$P_w = b \cdot Q \cdot m \cdot T_p \cdot k$$

$$Q = \text{Ratio factor for external gear pair} = \frac{2 \cdot T_g}{T_g + T_p}$$

$$d_p = \text{Diameter of pinion} = m \cdot T_p$$

$$\text{Here } T_g = 29, T_p = 17$$

$$\text{So that } Q = 1.260$$

$$k = \frac{\sigma_c \cdot \cos \phi \cdot \sin \phi}{1.4} \left( \frac{1}{E_1} + \frac{1}{E_2} \right)$$

$$k = \frac{[(0.27) \cdot (9.81) \cdot (\text{BHN})]^2 \cdot \cos(20) \cdot \sin(20)}{1.4}$$

$$k = \frac{[(0.27) \cdot (9.81) \cdot (150)]^2 \cdot \cos(20) \cdot \sin(20)}{1.4}$$

$$k = 1.010$$

$$P_w = 10^3 \cdot m^3 \cdot 1.260 \cdot m^3 \cdot 17 \cdot 1.010$$

$$P_w = 216.342 \text{ m}^2 \text{ N}$$

#### 5.2.5 Steering Torque

Considering the total weight of the vehicle with the driver to be  $140+60=200$  kgs and considering 45:55 weight distribution,

Assuming friction force to be maximum, so  $\mu=0.95$ ,

$$F_r = \mu \cdot N$$

$$F_r = 0.95 \cdot 882.9$$

$$F_r = 838.75 \text{ N}$$

#### 6. Conclusion

The objective of designing the effective steering system with high safety and low production costs seems to be accomplished. The design is first conceptualized based on personal experiences and intuition. Engineering

principles and measurement and calculations are then used for its designing.

#### 7. Acknowledgment:

The design process is not a single handed effort but a team effort. We would also like to express our gratitude towards the Mechanical department and on the whole towards the college for the support. The team would also like to recognize the valuable assistance of the project guide, Prof. A.S.Sakhare Sir, Mechanical Engineering Department, PRMIT&R.

#### 8. References

- i) Thomas D. Gillespie, Fundamentals of vehicle dynamics, Society of Automotive Engineers, Inc. 400 commonwealth drive, Warrandale, PA 15096- 0001
- ii) William F. Milliken and Douglas L. Milliken, Race Car Vehicle Dynamics, Society of Automotive Engineers, Inc. 400 commonwealth drive, Warrandale, PA 15096-0001
- iii) Design and Manufacturing of an effective steering system for ATV and performance enhancement.
- iv) Designing of the rack and pinion gearbox for all terrain vehicles for the competition BAJA SAE INDIA.

#### 9. Biographies



##### Ajay Manikrao Tayde

He now pursuing bachelor of mechanical engineering in final year at Prof. Ram Meghe Institute of Technology and Research, Badnera Amravati.



##### Sanket Pandit Golhar

He now pursuing bachelor of mechanical engineering in final year at Prof. Ram Meghe Institute of Technology and Research, Badnera Amravati.



##### Shital Ravindra Ughade

He now pursuing bachelor of mechanical engineering in final year at Prof. Ram Meghe Institute of Technology and Research, Badnera Amravati.



**Nikita Ramdas Kakde**

He now pursuing bachelor of mechanical engineering in final year at Prof. Ram Meghe Institute of Technology and Research, Badnera Amravati.