

# DESIGN AND DEVELOPMENT OF ELECTRIC MOTORBIKE

Srinivas Mutyala, M.Tech(Cad/Cam)

Final Year Student, Department of Mechanical Engineering, GIT, GITAM UNIVERSITY, Vizag (A.P.)

\*\*\*

**Abstract** - Modern world demands the high technology which can solve the current and future problems. Fossil fuel shortage is the main problem now-a-days. Considering current rate of usage of fossil fuels will let its life up to next five decades only. Undesirable climate change is the red indication for not to use more fossil fuel any more. Best alternative for the automobile fuels to provide the mobility & transportation to peoples is sustainable electrical motor bike. Future e-motorbike is the best technical application as a visionary solution for the better world and upcoming generation. E-motorbike comprises the features like artificial intelligence, noiseless operation, low vehicle running cost, light weight vehicles,. E-motor bike is the most versatile future vehicle considering its advantages.

**Key words:** Innovative mixed cradle Frame, innovative bldc motor mounted Swingarm, Power Transmission, Speed and Drag, lithium ion battery pack, Calculations.

## 1. INTRODUCTION

Main reason to identify the need of finding and modifying E-Bike is to overcome the issue of the pollution in metro and urban areas. Considering the all class of society it is not reasonable for all to purchase (scooters, mopeds or motorcycles). So, combining both issues, environmental progress supporting and economical affordable alternative would be the best solution. Typical parts of E-Motorbike ( Brushless DC Motor(1KW), Throttle (Accelerator), Battery Storage (48V), Chain Drive, Swing arm, Frame, spring coil over damper and other motorbike parts .Fig(1) and Fig (2)

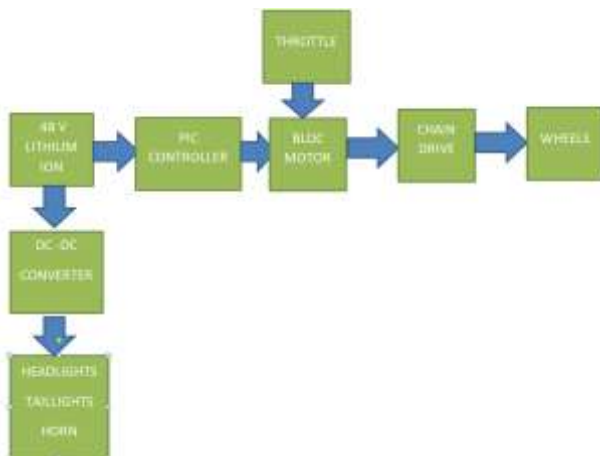

Figure (1) Electrical and mechanical Components of electric motor bike

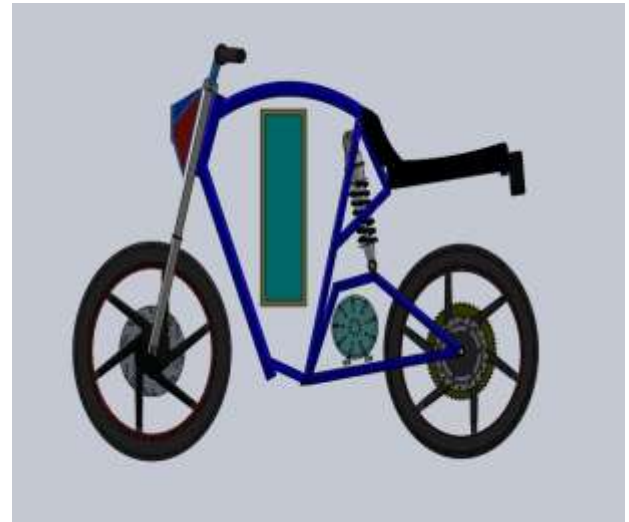

Figure (2) Mechanical and electrical components of electric motorbike.

## II. OBJECTIVE

Objective of this paper to was to explore the acceleration an electrically powered motorbike under Practical condition. Electric motorbike which can cruise up to 55 km/h using transmission ratio via chain drive . The main purpose of this research is to review the current situation and effectiveness of electric motorbike researched by various researchers.

### 1.1 ELECTRIC MOTORBIKE COMPONENTS

Electric motorbike consists of following components and calculations are made

- a) frame
- b) swingarm
- c) bldc motor inbuilt controller
- d) lithium ion battery pack
- e) power transmission
- f) steering
- g) wheels
- h) braking system.
- i) dc –dc converter
- j) accessories

**a)FRAME**

Frame is the backbone of electric motorbike, The Frame is made up of M.S. along with some additional light weight components. The frame is designed to sustain the weight of the person driving the unit, the weight of load to be conveyed and also to hold the accessories like motor. Normally recent motorbike frames are classified as stressed frames (where battery, bldc motor are stressed members)and non stressed members. In this new paper revolutionary innovative frame has been designed mixed cradle frame as shown in fig(3) and fig (4), recent motorbike consists either single cradle frame or double cradle frame ,so combining both single cradle frame and double cradle frame designed has been made .The mixed cradle frame consists of one upper tube and one down tube and two side tubes.



Figure (3) mixed cradle tube



Figure (4) mixed cradle frame

**b) SWINGARM AND MONOCOIL OVER DAMPER**

A swingarm, or "swinging arm", originally known as a swing fork or pivoted fork, is the main component of the rear suspension of most modern motorbikes and atvs. It

is used to hold the rear axle firmly, while pivoting vertically, to allow the suspension to absorb bumps in the road. Innovative swingarm had been designed as shown in figure (5) and figure (6) where bldc motor inbuilt controller is mounted.

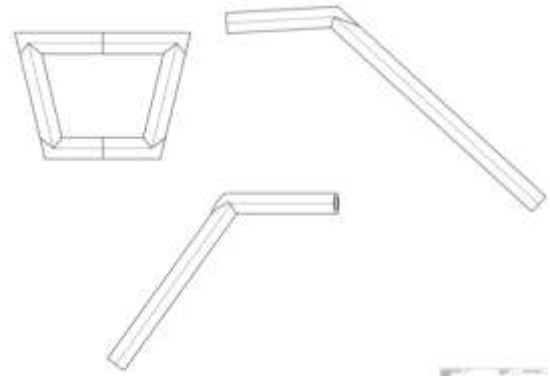

Figure (5) swing arm tubes

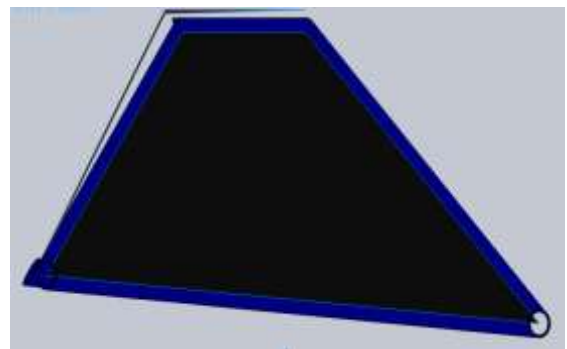

Figure (6) swing arm design

Swingarm supports the spring mono coil over damper as shown in fig (7) and fig (8). It is system of springs / dampers that connects wheels to the body / chassis. It tries to keep wheel in contact with ground it contributes to vehicles road handling and braking for active safe, it contributes towards rider and passengers comfort.



Figure (7) spring mono coil over damper



Figure (8) swing arm with mono spring coil over damper.

**c) BLDC MOTOR AND CONTROLLER**

Working of a BLDC motor are the same as for a brushed DC motor; i.e., internal shaft position feedback. In case of a brushed DC motor, feedback is implemented using a mechanical commutator and brushes. With a in BLDC motor as shown in fig (9), it is achieved using multiple feedback sensors. The most commonly used sensors are hall sensors and optical encoders.

Bldc motor advantages

- High starting torque
- Increased reliability.
- Reduced noise, longer lifetime (no brush and commutator erosion).



Figure (9) bldc motor

Technical specification of a bldc motor as shown in table (1), figure (10) and table (2)

power	1000 watts
voltage	48 volts
speed	2800 rpm
rated current	20 amps
weight	5kg
motor dia	161mm
motor length	115mm
shaft dia	222mm
shaft length	50mm

**c.1) Calculations**

$$P=2*3.14*N*T/60$$

Where

P=power of bldc motor (1 kw=1000 watt)

N=rpm of bldc motor

T=torque

$$1000=2*3.14*2700*T/60$$

$$T=3.63 \text{ NM}$$

Figure (10) bldc motor, pic controller and throttle

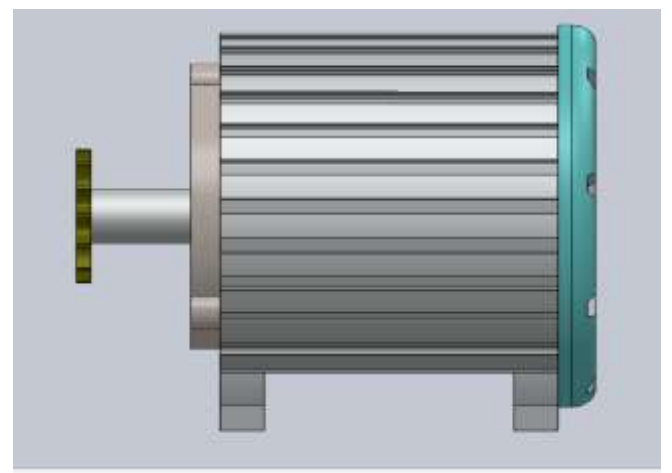
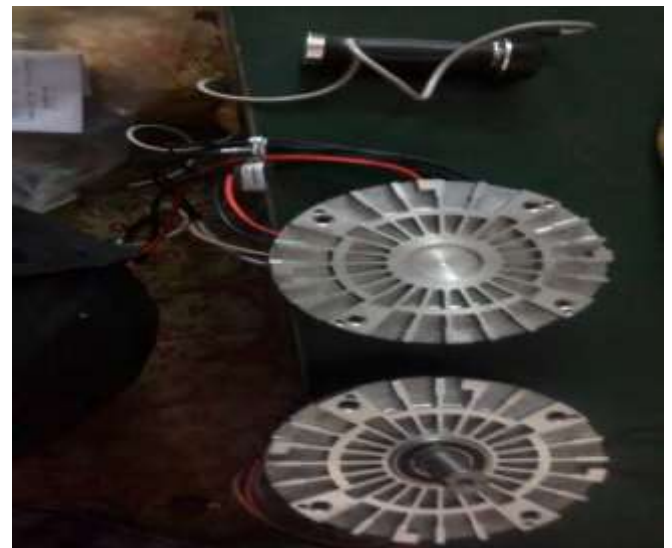



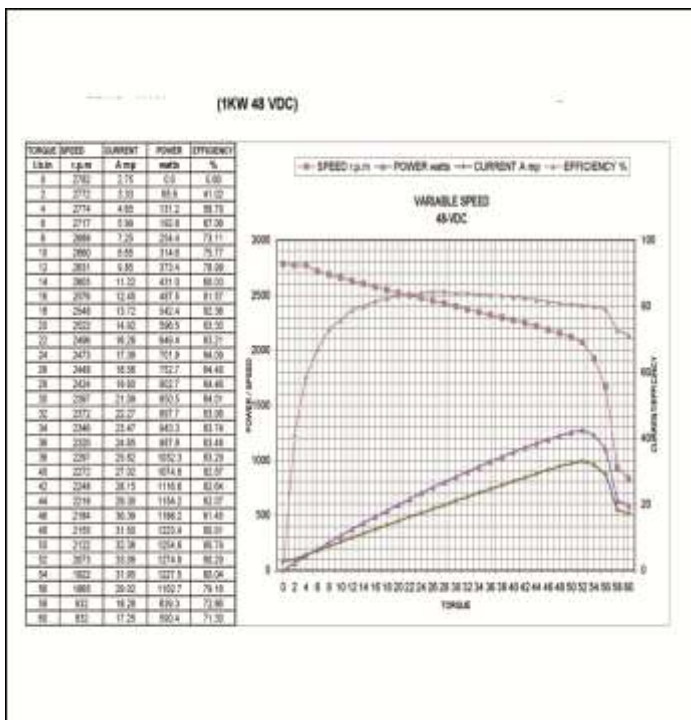

Table (2) current, voltage, rpm characteristics of a bldc motor

**Controller**

PIC16F72 controller as shown in fig(11) to control the electric motorbike system. In this electric motorbike system, some components are installed such as brushless dc motor; PIC controller and battery are required to the controller for controlling the different component of electric motorbike system. There are different functions of this controller such as under voltage protection, over current protection, control power supply, also to drive and control the Brushless dc motor. There are different signal was transmitted to pin of PIC controller to drive and control brushless dc motor, such as current detection signal, motor speed control signal, capacity detection system.

**PDIP, SOIC, SSOP**

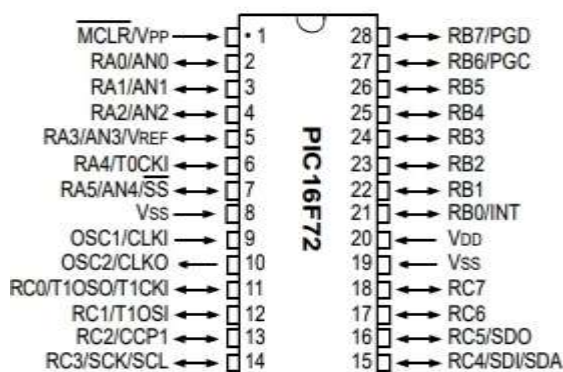

figure (11) Pic controller

**d) LITHIUM ION BATTERY PACK**

A lithium-ion battery or Li-ion battery is a type of rechargeable battery. Lithium-ion batteries as shown in fig (12 ) and specifications in table (3) are commonly used for portable electronics and electric vehicles and are growing in popularity for military and aerospace applications. High energy density - potential for yet higher capacities. Does not need prolonged priming when new. One regular charge is all that' needed. Relatively low self-discharge - self-discharge is less than half that of nickel-based batteries. Low Maintenance - no periodic discharge is needed.

Table (3) specifications of lithium ion battery

Battery type	Lithium ion
Voltage	48V
Amperes	40ah
Battery weight	8kg



figure (12) lithium ion battery pack

**E) POWER TRANSMISSION**

Power is transmitted from bldc motor shaft sprocket to rear wheel sprocket via chain drive. There are two sprockets, one sprocket which is attached to bldc motor shaft and other is attached to rear wheel of electric motorcycle as shown in fig (13) and figure (14).



Figure (13) front and rear sprockets



Figure (14) Chain and Sprockets of teeth 44, 54 and 60

The following design and dimensions of electric motorbike is designed and calculations are made. Convert inches in to mm 1 inch =25.4 mm.

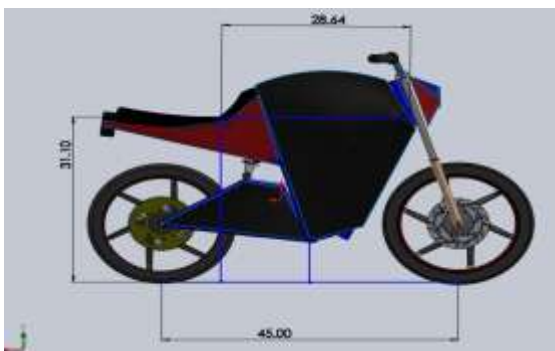
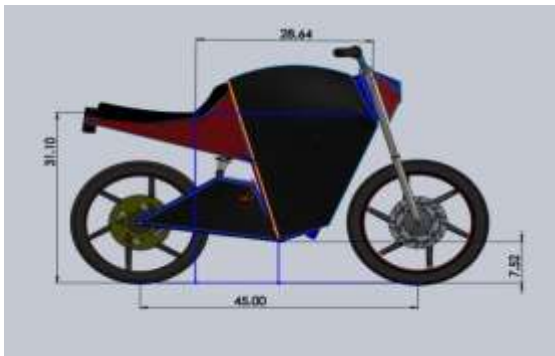

Figure (15) dimensions of electric motorbike all are in inches. 1inch=25.4mm.

### e.1) POWERTRAIN CALCULATIONS

#### CHAIN DRIVE CALCULATIONS

#### FINAL DRIVE RATIO SELECTION (I)

Drive ratio =4 (standard data book)

Max rpm of motor ( $N_1$ ) = 2700

Rear wheel rpm ( $N_2$ ) =  $2700/4 = 675$  rpm

No of teeth on the driver sprocket  $Z_1=15$  (standard data book)

No of teeth in the driven sprocket =

$$Z_2 = i * z_1 = 15 * 4 = 60$$

Standard Pitch selection

Design Power = Rated power \* Service Factor

Service Factor  $K = 1.4$

Design Power =  $1000 * 1.4 = 1400W$

From Standard table Chain no 12 can transmit the required power

Therefore Pitch  $p = 12.7$

Roller diameter  $d = 8.51mm$

Min width of roller = 8mm

Breaking load  $WB = 45kN$

Pitch circle diameter of smaller sprocket

$$D1 = p / \sin(180/z1) = 61.3mm$$

$$D2 = p / \sin(180/Z2)$$

$$= 244.42mm$$

Chain length(L) =  $l_p * p$

$L_p$  = no.of links

$p$  = pitch

Centre distance = 400 mm

$$a_p = a/p = 350/12.7 = 27.5$$

$$\text{no.of links} = \frac{2 * a_p + (Z_1(15) + Z_2(60)) / 2 + ((Z_2 - Z_1) / 2 * 3.14 * 3.14 / 27.5)}{1} = 94$$

$$\text{chain length} = 94 * 12.7 = 1193mm$$

Table (4) transmissions results

final drive ratio	4
centre distance	400mm
no.of links	94
chain length	1193mm
pitch	12.7mm
front sprocket dia	61.3mm
rear sprocket dia	244.42 mm

**e.2) SPEED CALCULATION**

Considering final drive calculation

Max rpm of motor = 2700

Drive ratio = 4

Rear wheel rpm = 2700/4  
= 675

Speed calculation formula

Converting rpm in to linear velocity

$$V = 2 * 3.14 * R * RPM * 60 / 1000$$

$$V = 2 * 3.14 * 0.228 * 675 * 60 / 1000$$

$$V = 57.98 \text{ km/ hr}$$

V = targeted speed km/ hr

R = radius of wheel in ( m)

**e.2) DRAG FORCE CALCULATION**

$$F_D = 1/2 C_d * A * \rho * v^2$$

$$= 1/2 * 0.05 * 0.44 * 1.2 * 57 * 57$$

$$= 42.88 \text{ N}$$

Where

A = frontal area for motor racing bikes (0.44)

ρ = air density (1.2 kg/m³)

c<sub>d</sub> = drag coefficient bikes (0.05)

rolling resistance

$$F_R = C_{RR} * W$$

$$= 0.006 * 808 * 10 \text{ crr ( 0.006 for racing bikes)}$$

$$= 4.8 \text{ N}$$

$$R_F = F_D + F_R = 42.88\text{N} + 4.8\text{N} = 47.6\text{N}$$

**f) STEERING**

Steering system consists of handlebar ,steering head .steering calculations are made based on design dimensions as shown in fig (16) ,fig (17) fig (18) and fig (19)

Table (5) steering parameters

Head tube angle	70°
Rake angle	20°
Offset	1 inch
wheelbase	1100 mm
Steering ratio	1:1

Rake angle 20° is chosen to have short turning radius and short handling.

Head tube angle for this bike is designed to 73°

Figure 2 --- Side View

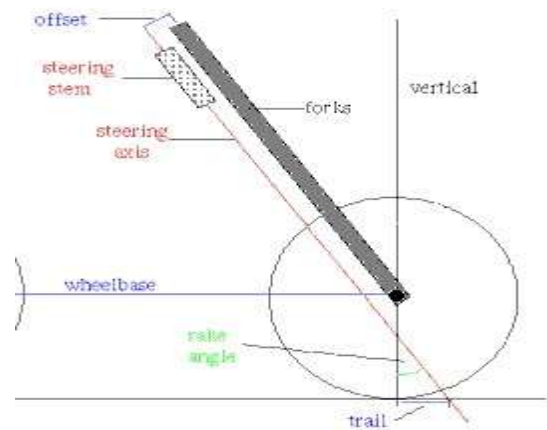

figure (16) steering parameters

Steering calculations

- 1) trail calculation
- 2) turning radius
- 3) leaning angle
- 4) wheel flip flop factor

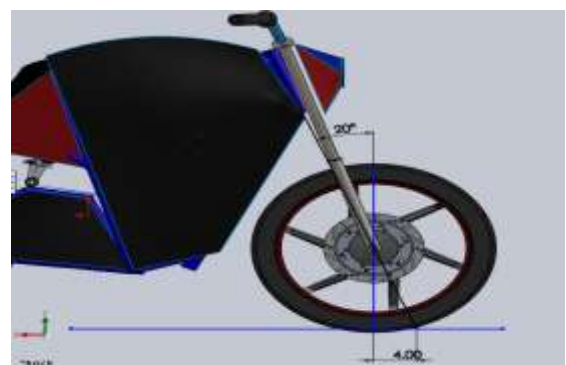

Figure (17) steering parameters



Figure (18) steering handlebar

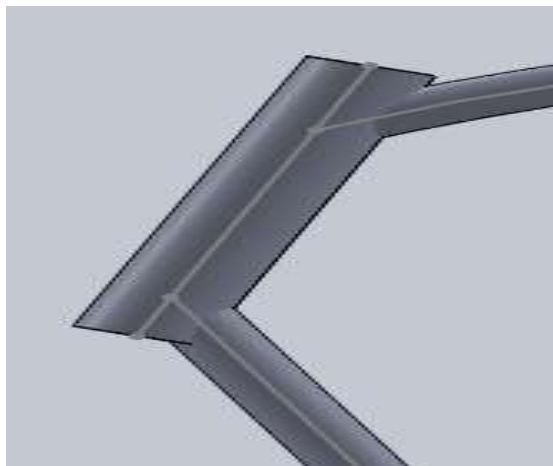

Figure (19) steeringhead

**f.1) CALCULATION**

1) Trail

$$\begin{aligned} \text{trail} &= R_w \sin(A_\mu) - \text{offset} \cos(A_\mu) \\ &= 228 \times \sin(20^\circ) - 25.4 \times \cos(20^\circ) \\ &= 54\text{mm} \end{aligned}$$

Where,  $R_w$  = wheel radius = 228mm  
 $A_\mu$  = Rake angle;  
 Of = offset.

2) Turning radius

$$\begin{aligned} \text{Turning radius} &= 2 \times (\text{wheel base}) \times \\ &\quad \sin(90^\circ - \text{wheel lock angle}) \\ &= 2 \times 1100 \times \sin(90^\circ - 20^\circ) \\ &= 2067.34\text{mm} \end{aligned}$$

3) Leaning angle

$$\text{Leaning angle } (\alpha) = \tan^{-1} (v^2 / r \times g)$$

Where,  $\alpha$  = Leaning Angle;

$r$  = Turning Radius

$g$  = Acceleration Due To Gravity

$$\alpha = [\tan^{-1} (20 \times 20 \times 0.277 \times 0.277)] / [2 \times 9.81]$$

$$\alpha = 53.91^\circ$$

4) Wheel flip flop factor

$$\text{Wheel flip flop factor (l)} = b \times \sin(U) \times \cos(U)$$

Where,  $U$  = Head angle;

$b$  = Trail;  $l$  = wheel flip flop factor

$$l = 54 \times \sin(70) \times \cos(70) = 18$$

Calculated values

Table (6) steering results

Trail value	54mm
Turning radius	2.06m
Leaning angle	53.91°
Wheel flip flop factor	18

**g) WHEELS**

Wet type tyres as shown in figure (20), fig(21) and fig (22) are used so that the electric motorbike can easily commute in all seasons in urban areas to prevent aqua planning. Good contact patch, in rainy condition (throwing water radially), Puncture resistant (up to 30 kms), Long life (up to 5000 kms), Durability, Less weight Good Commuting purpose. The 17 inches tubeless 90/90 front and 110/90 rear wet/rain tyres are chosen



Figure (20) wet type tyre rear wheel



Table (7) tyres specifications)

Type of tyres	Wet/rain
Tyres manufacturer	MRF tubeless tyres
Tyres front size	90/90
Rear tyre size	110/80
Tyre design for bikes	Commuter bikes



Figure (22) spokeless rims



Figure (21) rear wheel 110/80 size



Figure (21) front wheel 90/90 size

Spokeless rims are selected Less weight Good cornering Stability.

### h) BRAKING

Brakes system follow Pascal's law. Independently actuated front and rear brake system specifications and as shown in table (8) and figure (23).

Brake system components

- Reservoir
- Master cylinder
- Brake lever
- Caliper
- Disc

Table (8) brake system specifications

items	type/dimensions
caliper	floating
number of piston(front and rear)	2
disc front diameter	260mm
rear disc diameter	260mm
master cylinder	single pot, smaller dia for maximum pressure
brake hose	steel wired and rubber coated hose



Figure (23) brake system caliper



**i) DC -DC CONVERTER**

A DC-to-DC converter is an electronic circuit or electromechanical device that converts a source of direct current (DC) from one voltage level to another. It is a type of electric power converter. Power levels range from very low (small batteries) to very high (high-voltage power transmission). The output of lithium ion battery pack is 48V, it has to be converted in to 12V for functioning of accessories like headlights, horn, tail lights so dc -dc converter as shown in are used.



Figure (24) 48V -12V dc-dc converter

**j) ACCESSORIES**

Accessories like headlights (25), taillights, horn, rider seat, legguard, body panels. headlights for night vision of roads recent technology daylight running lights as shown in fig (25).taillights for indication of turns as shown in figure (26), legguards for vehicle protection and rider seat for comfortable sitting riding manoeuvrability for rider. Kill switch for emergency stoppage to cut the power supply as shown in figure (27). Mirrors for visibility of behind vehicles as shown in figure (28)



Figure (25) front view of headlights



Figure (26) indicators and brake light switch



Figure (27) emergency kill switch



Figure (28) mirror

Body panels as shown in fig (29), the design of the body parts are done by using cad in solid works software. The FRP is selected for the body works of very less weight. The body panels are made out of the fiber reinforced plastic .The composite material is made of the polyester thermosetting plastic, epoxy resins. It is the composite material made of the matrix reinforced with fibers. FRP

is very light material which has desirable properties to make the body panels.

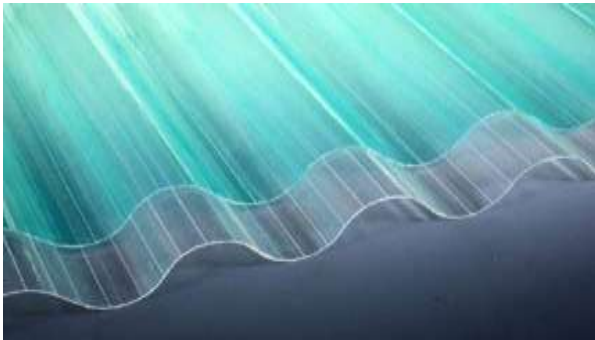

Figure (29) body panels fibre reinforced plastics

Overall design and development of electric motorbike in solid works modelling softwares and in reality practical prototype electric motorbike.



Figure (31) top view



Figure (30) side view



Figure (32) prototype side view



Figure (31) front view



Figure (33) side view of prototype



Figure (34) side view of prototype motorbike without bodypanels..

### III) CONCLUSION

The objective of a comfortable, compact, medium speed and efficient motorbike can be achieved by this various experiment results obtained by different authors by advancement in current E-motorbike model. With the help of these research paper we are able to design an electric motorbike which may be the solution to our problems which we are experience now a days like traffic congestion, parking difficulties and pollution from fossil fueled vehicles. We innovate an idea to develop an e-motorbike which discard the orthodox mentality of ic engines. This paper presents the results from a year-long study into electric motorcycle effectively. This paper identifies potential barriers of electric motorcycle. The above prototype electric - motorbike had been tested in practical conditions.

### IV) REFERENCES

- [1] Chetan Mahadik ,Sumit Mahindrakar, Prof. Jayashree Deka "An Improved & Efficient Electric Bicycle system with the Power of Real-time Information Sharing" Published by Multidisciplinary Journal of Research in Engineering and Technology, Volume 1, Issue 2, Pg.215222 on 2014
- [2] R.S Jadoun & Sushil Kumar Choudhary "Design and fabrication of dual chargeable bicycle " Published by Innovative Systems Design and Engineering www.iiste.org ISSN 2222-1727 (Paper) ISSN 2222-2871 (Online) Vol.5, No.8, 2014
- [3] Darshil G. Kothari, Jaydip C. Patel, Bhavik R. Panchal "Hybrid Bicycle" Published by IJEDR | Volume 2, Issue 1 | ISSN: 2321-9939 in 2014

[4] Rahul Sindhwani, Punj L. Singh , Anjum Badar , Ankur Rathi, Design Of Electric Bike With Higher Efficiency, International Journal of Advance Research and Innovation Volume 2, Issue 1 (2014) 247-251 ISSN 2347 - 3258

[5] M. Reddi Sankar, T. Pushpaveni, V. Bhanu Prakash Reddy, Design and Development of Solar Assisted Bicycle, International Journal of Scientific and Research Publications, Volume 3, Issue 3, March 2013 ISSN 22503153

[6] Rajendra Beedu, Ankit, Mohmed Asif Shaik, Sushant Jain, Design, Fabrication And Performance Analysis Of Solar Power Bicycle, International Journal of Renewable Energy and Environmental Engineering ISSN 2348-0157, Vol. 02, No. 03, July, 2014

[7] R.S Jadoun, Sushil Kumar Choudhary, Design And Fabricatio Of Dual Chargeable Bicycle, InnovativeSystems Design and Engineering, www.iiste.org ISSN2222-1727 (Paper) ISSN 2222-2871 (Online) Vol.5, No.8, 2014

[8] Akshay, N. Khonde, Aditya R. Ughade, Kapil D. Warghane, Rajat R. Vidhale Students, Performance Evaluation of Electric Bicycles, IARJSET ISSN (Online) 2393-8021 ISSN (Print) 2394-1588 International Advanced Research Journal in Science, Engineering and Technology, Agni-Pankh 16-Jawaharlal Darda Institute of Engineering and Technology, Yavatmal-Vol. 4, Special Issue 3, January 2017