

Automatic Medicine Remainder using Arduino

WALEED HUMAID¹, MOHAMMAD MOHATRAM²

¹Student at Global College of Engineering and Technology, Muscat, Oman

²Senior Lecturer at Global collage of Engineering and Technology, Muscat, Oman

Abstract – This paper propose persistent prescription update is a framework which helps in medicine organization and checking. This framework comprises of an ATMEGA328P microcontroller with an inbuilt EEPROM and a continuous circuit. This framework is driven by an installed program that information sources predefined parameters which are prepared dependent on the information factors entered by means of a UI gadget, for example, the keypad. Every one of the passages made on the keypad are simultaneously and at the same time showed on the LCD board of the gadget. The rationale for the preparing is incorporated with the inserted program to start the caution through a sound alert. In addition to the fact that it has an alert framework, yet additionally a LCD which shows the drug to be taken at the update time.

Key Words: Crystal oscillator, Buzzer, Atmega328/P, Keypad, LCD screen, Power Supply Unit and Resistor, 7085 Voltage regulators.

1. INTRODUCTION

The quantity of occupants in people is extending rapidly, and as people grow increasingly prepared, they make memory challenges. Thusly, progressively prepared people may disregard to take as a lot of time as important or ignore that they have successfully taken their remedies. In this way, they miss estimations of drugs, or take overdoses. To deal with this issue, we sketched out and collected an electronic system, which can be acquainted in a medication agency with screen a man's affirmation of meds. The system criteria have taken after (a) negligible exertion, (b) accommodation, (c) unfaltering quality, and (d) likeness with different authority composes, and tranquilize bottles more particularly, the creation gives procedures and structures to managing a man's answer agency with a PC structure related with the database nearby the sensor.

Regular pharmaceutical cabinets basically part with an instrument to putting a man's medication. Exactly when the remedy department is arranged in a house in which a family lives, it isn't astonishing for the arrangement authority to contain pharmaceuticals for different people from the nuclear family. This displays the probability that one individual may take remedy unintentionally that is suggested for a substitute person. Similarly, it isn't astonishing that a man will disregard to have a medication topped off until the point that he takes the last pill of his answer. With the present involved lifestyles, people every now and again consume their medications at an inappropriate time or in an inappropriate whole. Besides, people are much of the time

not aware of new notification about adversarial effects and medicine correspondences for different arrangements. It offers assistive hints to patients as prompts and refreshes and depicts our hardware and programming plot examinations of this therapeutic structure for managing arrangement of individuals.

Some of the time it is hard to recollect the prescription and measurement. This framework can likewise be helpful in clinic where number of patients is available and additionally for the patients who used to take standard medication at home. So, this framework with certain updates can likewise be utilized in emergency clinics/homes.

1.1. The issue, for example:

- 1) Maintaining the normality of endorsed measurement is hard to be recollected in occupied plan
- 2) Remembering the right time and name of medication to be taken is truly troublesome
- 3) Due to over two reasons the patient's life can get progressively confounded.

These above issues are emerging to everybody due to non-adherence of prescriptions. In this manner, there is a developing need and direness for in-home human services gadgets and advances to furnish patients with the electronic devices to help drug self-administration

2. LITERATURE REVIEW

2.1. BACKGROUND

- ARDUINO OPEN SOURCE

Arduino is open-source gadgets prototyping stage dependent on adaptable, simple to utilize equipment and programming. Today we will assist you with beginning by giving you a portion of the alternatives accessible and that it is so natural to begin.

Arduino equipment is an open-source circuit board with a chip and info/yield (I/O) pins for correspondence and controlling physical articles (LED, servos, catches, and so on.). The board will regularly be fueled through USB or an outer power supply which thus enables it to control other equipment and sensors. Arduino likewise has an open-source programming part which is like C++. The Arduino coordinated advancement condition (IDE) enables you to compose code, accumulate it, and afterward transfer it to

your Arduino for independent use in prototyping and ventures. The entirety of this was intended to be anything but difficult to use to let craftsmen and producers uninhibitedly form their thoughts into genuine items. In the event that you are keen on building something yourself, view see the equipment choices, and programming accessible to kick your off.

2.2. LITERATURE REVIEW

• A Smartphone-based Medication

Most patients don't recollect their whole drug routine and they additionally sometimes neglect to take their prescription [1]. Outpatients with interminable sicknesses, especially the individuals who must oversee more than one prescription or take drug more than once per day, may not take their meds appropriately. The pace of drug adherence, characterized as "the degree to which the patient adheres to restorative guidelines", has been accounted for to be around 50–80% [2-4]. Quiet adherence to prescription is clinically critical in lessening mortality of genuine infection and complete medicinal services costs. By and by, the above-depicted issues have opposed an answer for quite a while [5, 6].

The most widely recognized patient-related factor coming about in non-adherence incorporate 'essentially overlooked', although prescription adherence is a multidimensional wonder [2, 3, 7]. The pace of 'just overlooked' was 66% in HIV/AIDS clinical preliminaries and 30% in other clinical preliminaries [3, 7]. Ongoing examinations have recommended that forthcoming memory, which depicts one's capacity to make sure to accomplish something sometime in the not too distant future, is a significant segment in medicine adherence [8]. Thus, helping patients make sure to take their prescription is a basic and powerful approach to improve adherence.

As data and correspondence innovation (ICT) builds up, a framework utilizing cell phones to help prescription taking will turn out to be progressively vital as a piece of the mHealth (versatile wellbeing) framework [9, 10], in light of the fact that cell phones are simple for patients to convey even in case of a crisis or a catastrophe. Late examinations have indicated that update-based intercessions utilizing a short message administration from cell phones improved prescription adherence [11-13]. mHealth frameworks, yet in addition various different kinds of self-administration instruments for medicine have been distributed, i.e., update bundling, electronic drug screens, and cell phone programming for prescription administration [11-18].

• Android based Medication Reminder

Any living being can be a patient which may incorporate people, creatures, pets, and so on. The patients under individual class may incorporate specialist, social laborers, government officials, educators, understudies, and so on. These individuals may occupy in their every day schedule life

plan. On the off chance that they are experiencing any sort of legitimate amount at appropriate time. On the off chance that the patient is at home, at that point the relatives may recollect and reminds patient to take the prescriptions. However, it isn't feasible for the relatives to give update by calling them when the patient individual is out of home/city. For this reason, there ought to be some office for the patients which will remind them about their prescription required some investment.

Now days there are large number of mobile phone/smart phone users in the world. The bulky number of variety of applications available in the mobile phone made the luxurious life. Mobile phone companies are providing such a wonderful application for their users then question arises in mind that why not to use those applications when company is providing them? Out of those applications, Reminder facility in the mobile phone is the most commonly used application which is used for preventing to remember each and every small thing.

Most out-patient medication errors were made when patients bought prescribed medicines from different drug stores and use them at home without guidance. Common causes of these errors include: a) irregular medicine in-takes due to the patient's busy schedule, b) complicated in-take schedules due to the large number of medicines taken by the patient, c) adverse drug reactions caused by un-reconciled prescriptions obtained from different sources, d) lack of knowledge about proper use of medicines[20]

An Android based application for the patients to remind them to take legitimate medications in appropriate amount at appropriate time via naturally setting the updates in the portable was presented in (citation). The authors claimed that this application is quite useful to adhere to the medicine plan prescribed by the doctor.

3. METHODOLOGY

3.1 PROJECT OVERVIEW

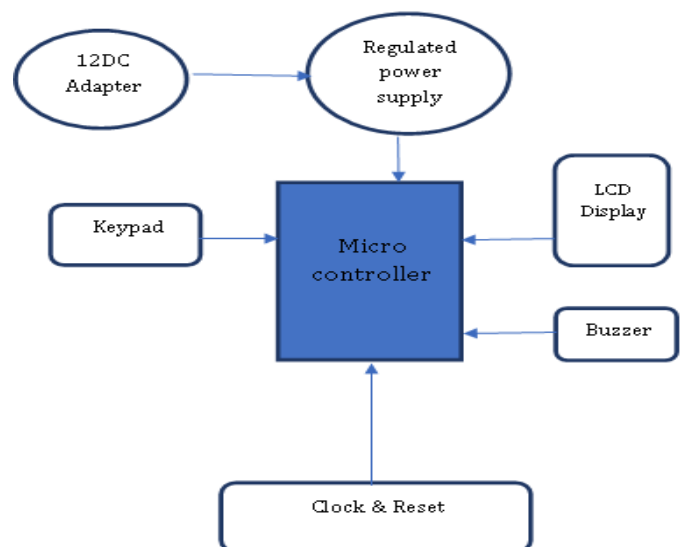

Figure 1; Block diagram of the system

3.3 Reset

The reset line has an inside draw up resistor. In any case, if nature is loud, it tends to be inadequate and reset may happen sporadically. Interfacing the RESET to such an extent that it is conceivable to enter both high-voltage programming and standard low-level reset can be accomplished by utilizing a dismantle up resistor to the RESET line. This draw up resistor maintains a strategic distance from any unintended low sign that will trigger a RESET. Hypothetically, the draw up resistor can be of any worth, however if the Atmel AVR ought to be modified utilizing an outside developer, the draw up ought not be in such a high express, that the software engineer can't enact RESET by drawing the RESET line low. The prescribed draw up resistor esteem is $4.7k\omega$ or bigger. To shield the RESET line from further commotion, associate a capacitor from the RESET stick to ground. This isn't legitimately required since the AVR inside have a low-pass channel to dispense with spikes and commotion that could cause reset. Utilizing an additional capacitor is an extra assurance. On the other hand, a Zener diode can be utilized to confine the RESET voltage comparative with GND. A Zener diode is exceptionally suggested in boisterous situations. The parts ought to be found physically near the RESET stick of the AVR. Prescribed circuit on RESET line is appeared.

If an outer switch is associated with the RESET stick, it is essential to include an arrangement opposition. At whatever point the switch is squeezed, it will short the capacitor and the current through the switch can have high pinnacle esteems.

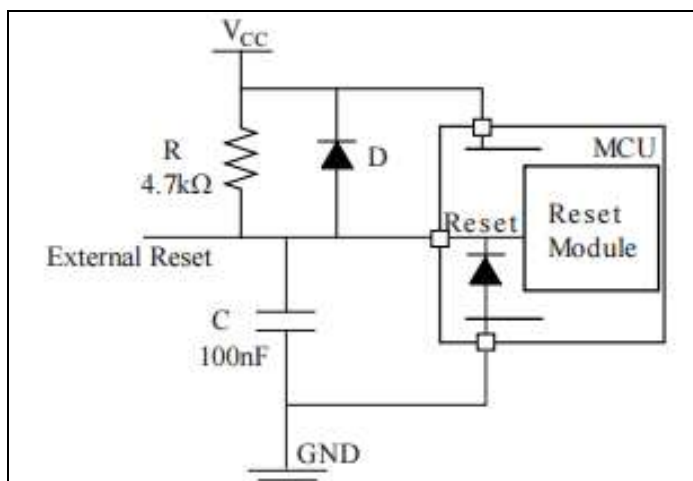

Figure 2: Reset circuit

3.4 Crystal Oscillator

A Crystal oscillator is an electronic oscillator circuit that uses the mechanical reverberation of a vibrating gem of piezoelectric material to make an electrical sign with an exact recurrence. This recurrence is generally used to monitor time, as in quartz wristwatches, to give a steady clock sign to

advanced coordinated circuits, and to balance out frequencies for radio transmitters and beneficiaries. The most widely recognized kind of piezoelectric resonator utilized is the quartz precious stone, so oscillator circuits fusing them got known as gem oscillators, however other piezoelectric materials including polycrystalline earthenware production are utilized in comparative circuits (Aduiopedia, 2014).

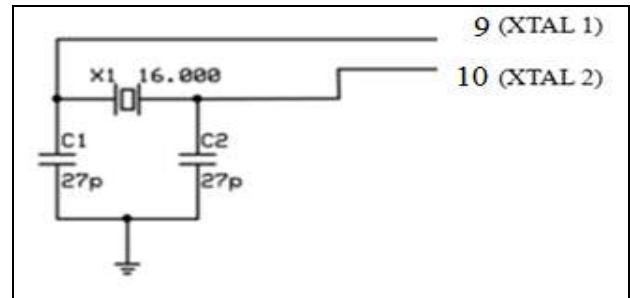

Figure 3: Clock circuit

3.5 A liquid crystal display

A liquid crystal display (LCD) is a slim, level electronic visual show that uses the light balancing properties of fluid gems (LCs). LCs don't emanate light legitimately. They are utilized in a wide scope of utilizations including PC screens, TV, instrument boards, flying machine cockpit shows, signage, and so forth. They are basic in purchaser gadgets, for example, video players, gaming gadgets, timekeepers, watches, mini-computers, and phones. LCDs have uprooted cathode beam tube (CRT) shows in many applications. They are typically increasingly minimized, lightweight, versatile, more affordable, progressively dependable, and simpler on the eyes (Books, 2010)



Figure 4: Liquid crystal display

3.6 Power supply

Most microcontrollers work over a wide voltage range and draws just a couple milli amps of supply current. However, similarly as with any computerized circuits, the stockpile current is a normal worth. The current is attracted short spikes on the clock edges. If I/O lines are exchanging, the spikes will be much higher. On the off chance that each of the eight I/O lines of an I/O port changes esteem, at the same time, the present heartbeats on the power supply lines can be a few hundred mA. If the I/O lines are not stacked, the beat will keep going for just a couple of nanoseconds. Such a present spike can't be conveyed over long control supply

lines; the principle source is the decoupling capacitor. In Atmel AVR gadgets where power and ground lines are set near one another there will be preferable decoupling over the gadgets with industry standard stick out. In industry standard stick out, the power and ground pins are put in inverse corners of the DIP bundle. This burden can be overwhelmed by putting decoupling capacitors near the kick the bucket. For gadgets with various sets of intensity and ground pins, it is basic that there is a decoupling capacitor for each pair of pins. The principle control supply ought to likewise have a tantalum or artistic capacitor to balance out it.

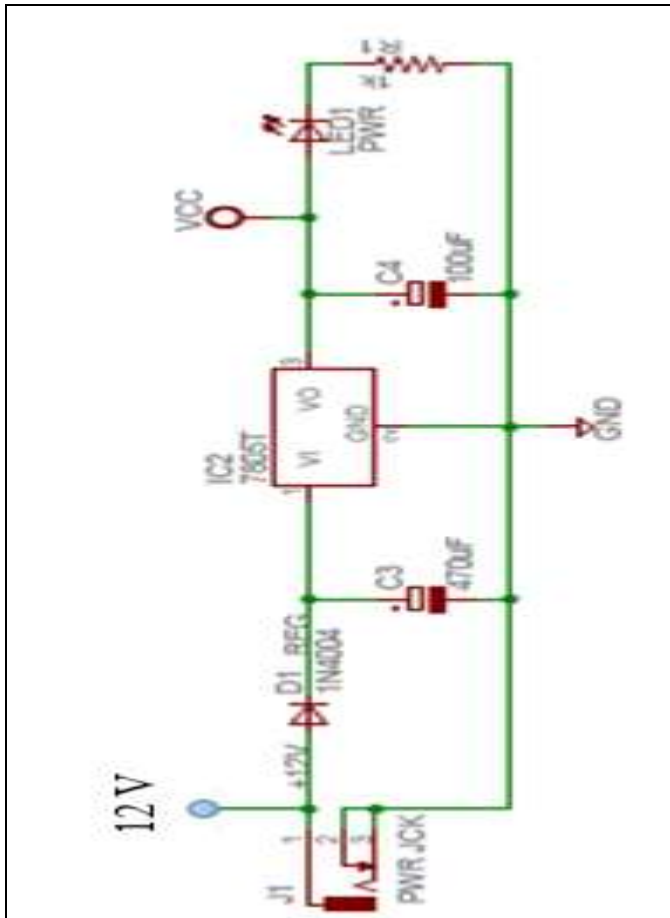

Figure 5: Power supply circuit

3.6 Keypad

A keypad is a lot of catches organized in a square or "cushion" which as a rule bear digits, images and typically a total arrangement of in order letters. In the event that it generally contains numbers, at that point it can likewise be known as a numeric keypad. Keypads are found on numerous alphanumeric consoles and on different gadgets, for example, adding machines, push-button phones, blend locks, and computerized entryway locks (Code Bender, 2015). So as to recognize which key is squeezed from the network, the line lines are to be made low individually and read the segments. On the off chance that any of the keys in row1 is squeezed, at that point correspondingly the segment 1 will give low, that is

on the off chance that the subsequent key is squeezed in Row1, at that point column2 will give low.



Figure 6: Keypad

3.6 Voltage Regulator

In this paper I used 7805 voltage regulator which is a three terminal direct voltage controller IC with a fixed yield voltage of 5V which is helpful in a wide scope of uses. Right now, the 7805 Voltage Regulator IC is produced by Texas Instruments, ON Semiconductor, STMicroelectronics, Diodes joined, Infineon Technologies, and so on.

They are accessible in a few IC Packages like TO-220, SOT-223, TO-263 and TO-3. Out of these, the TO-220 Package is the most normally utilized one (it is the one appeared in the underneath picture).

A portion of the significant highlights of the 7805 IC are as per the following:

- It can convey up to 1.5 an of current (with heat sink).
- Has both interior current constraining and warm shutdown highlights.
- Requires exceptionally least outside segments to completely work.

As referenced before, 7805 is a three-terminal gadget with the three pins being 1. Info, 2. GROUND and 3. Yield. The accompanying picture shows the pins on a regular 7805 IC in To-220 Package.

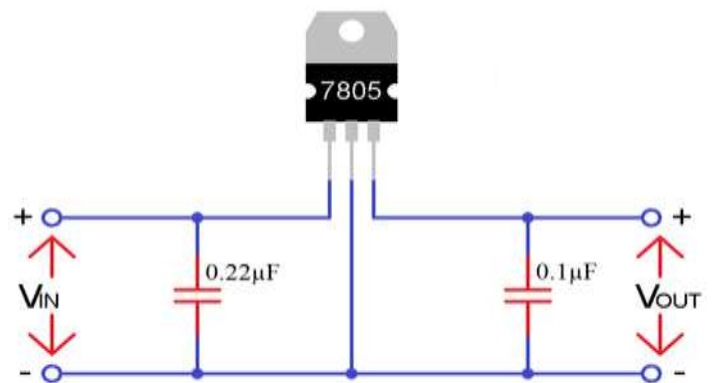

Figure 7: Voltage regulator

4. TEST AND DISCUSSIONS

At the point when the gadget is at first controlled on, it should be arranged through the arrangement menu. The gadget has 12 fastens that enable the client to explore the arrangement menus. The gadget is first placed into arrangement mode; this is finished by squeezing the "*" button. When the gadget is in Setup mode, the client can set the time, and set the time interims and name of medication to be taken. This data is then spared to the microcontroller's EEPROM, so arrangement just should be performed once, regardless of whether the gadget is unplugged incidentally. The gadget at that point utilizes the setup characterized by the client to set up cautions that remind the client to take the proper drug name at the set occasions. At the point when a caution is enacted, the drug name is likewise appeared on the LCD screen to set off the alert; the gadget checks the time which is contribution to minutes when the caution is switch off the gadget spares that time esteem. The gadget at that point totals the interim indicated for the caution and spares that incentive as an alert. For instance, if the time is 9 PM and the interim is 2 hours, the gadget would set the caution for that specific opening to 10.



Figure 9: Display of medicine one, two and their times for the alarm



Figure 8: when the circuit is powered

The above picture shows what happens before the medicine name and the time are set for the circuit. LCD screen that enables to output at least three types of medicine at the time set for their alarms. Keypad contains 12 buttons that enabled us to input both medicine name and the time for the alarm that is made by the buzzer. The buzzer is set to be sounded for 4 seconds so that the patients can get the alarm very well. In the LCD.

5. CONCLUSIONS

Numerous Medication Reminder Systems have been created on various stages. A considerable lot of these frameworks require unique equipment gadgets to remind the patients about the drug in-take timings. Acquiring new equipment gadgets turns out to be expensive and additional time and cash devouring. So in the given work, an endeavor has been made to actualize a framework which will be prudent, effectively available and improves drug adherence. Persistent Medication update framework will decrease the viability of a treatment and forces a money related trouble on medicinal services frameworks. The patients will get the calendar of medication in-require some investment with medication portrayal, beginning and completion date of medication, warning through fluid precious stone presentation (LCD), programmed alert ringing framework. The booked update will propose the sort of medication the patient will take at the specific time of the caution.

5.1 Further Work

During the system testing it was observed that can use for three or four medication. Given that the user for one patient. For instance, when the use microcontroller became limit because capacity of microcontroller is for three or four medication. Such cases could be avoided by memory insert and change code od microcontroller. This would involve creating a model of the code and memory which contains the possible to get from one Patient to mulit-patient.

ACKNOWLEDGEMENT

I might want to express gratitude toward Aje among other instructor in instructors for giving the direction and backing through the undertaking. Additionally, the scholastic counsel Dr. M.Mohmmmed for his thoughtful help in the product related issues that I have been toss. The lab specialist staff Mohammed Al-Jabri for responding to my specialized

inquiries rapidly and completely just as providing the parts for the task.

REFERENCES

- [1] Eagleton J, Walker F, Barber N. An investigation into patient compliance with hospital discharge medication in a local population. *Int J Pharm Pract* 1993; 2: 107-109 [Google Scholar]
- [2] World Health Organization Adherence to Long-Term Therapies: Evidence for Action. Geneva, Switzerland: World Health Organization; 2003. [Cited 2012 June 27]. Available from: http://www.who.int/chp/knowledge/publication/s/adherence_full_report.pdf [Google Scholar]
- [3] Osterberg L, Blaschke T. Adherence to medication. *N Engl J Med* 2005; 353(5): 487-497 [PMID:16079372] [PubMed] [Google Scholar]
- [4] Haynes RB, Ackloo E, Sahota N, McDonald HP, Yao X. Interventions for enhancing medication adherence. *Cochrane Database Syst Rev* 2008; 2: CD000011 [PMID:18425859] [PubMed] [Google Scholar]
- [5] Simpson SH, Eurich DT, Majumdar SR, Padwal RS, Tsuyuki RT, Varney J, et al. A meta-analysis of the association between adherence to drug therapy and mortality. *BMJ* 2006; 333(7557): 15-21 [PMID:16790458] [PMC free article] [PubMed] [Google Scholar]
- [6] Bosworth HB, Granger BB, Mendys P, Brindis R, Burkholder R, Czajkowski SM, et al. Medication adherence: A call for action. *Am Heart J* 2011; 162(3): 412-424 [PMID: 21884856] [PMC free article] [PubMed] [Google Scholar]
- [7] Chesney MA, Ickovics JR, Chambers DB, Gifford AL, Neidig J, Zwickl B, et al. Self-reported adherence to antiretroviral medications among participants in HIV clinical trials: the AACTG adherence instruments. *AIDS Care* 2000; 12(3): 255-266 [PMID:10928201] [PubMed] [Google Scholar]
- [8] Zogg JB, Woods SP, Saucedo JA, Wiebe JS, Simoni JM. The role of prospective memory in medication adherence: a review of an emerging literature. *J Behav Med* 2012; 35(1): 47-62 [PMID:21487722] [PMC free article] [PubMed] [Google Scholar]
- [9] Boulos MNK, Wheeler S, Tavares C, Jones R. How smartphones are changing the face of mobile and participatory healthcare: an overview, with example from eCAALYX. *Biomed Eng Online* 2011; 10: 24-37 [PMID:21466669] [PMC free article] [PubMed] [Google Scholar]
- [10] Clifford GD, Clifton D. Wireless Technology in Disease Management and Medicine. *Ann Rev Med* 2012; 63: 479-492 [PMID:22053737] [PubMed] [Google Scholar]
- [11] Fenerty SD, West C, Davis SA, Kaplan SG, Feldman SR. The effect of reminder systems on patients' adherence to treatment. *Patient Prefer Adher* 2012; 6: 127-135 [PMID:22379363] [PMC free article] [PubMed] [Google Scholar]
- [12] Lester RT, Ritvo P, Mills EJ, Kariri A, Karanja S, Chung MH, et al. Effects of a mobile phone short message service on antiretroviral treatment adherence in Kenya (WelTel Kenya1): a randomised trial. *Lancet* 2010; 376: 1838-1845 [PMID:21071074] [PubMed] [Google Scholar]
- [13] Da Costa TM, Barbosa BJP, E Costa DAG, Siquem D, Marin HF, Filho AC, et al. Results of a randomized controlled trial to assess the effects of a mobile SMS-based intervention on treatment adherence in HIV/AIDS-infected Brazilian women and impressions and satisfaction with respect to incoming messages. *Int J Med Inform* 2012; 81(4): 257-269 [PMID:22296762] [PMC free article] [PubMed] [Google Scholar]
- [14] Mahtani KR, Heneghan CJ, Glasziou PP, Perera R. Reminder packaging for improving adherence to self-administered long-term medications (Review). *Cochrane Database Syst Rev* 2011; 9: CD005025 [PMID:21901694] [PubMed] [Google Scholar]
- [15] Zedler BK, Kakad P, Colilla S, Murrelle L, Shah NR. Does packaging with a calendar feature improve adherence to self-administered medication for long-term use? A systematic review. *Clin Ther* 2011; 33(1): 62-73 [PMID:21397775] [PubMed] [Google Scholar]
- [16] Vrijens B, Vincze G, Kristanto P, Urquhart J, Burnier M. Adherence to prescribed antihypertensive drug treatments: longitudinal study of electronically compiled dosing histories. *BMJ* 2008; 336(7653): 1114-1117 [PMID:18480115] [PMC free article] [PubMed] [Google Scholar]
- [17] Haberer JE, Robbins GK, Ybarra M, Monk A, Ragland K, Weiser SD, et al. Real-Time electronic adherence monitoring is feasible, comparable to unannounced pill counts, and acceptable. *Behav AIDS* 2011; 16(2): 375-382 [PMID:21448728] [PMC free article] [PubMed] [Google Scholar]
- [18] Hayes TL, Hunt JM, Adami A, Kaye JA. An electronic pillbox for continuous monitoring of medication adherence. *Conf Proc IEEE Eng Med Biol Soc* 2006; 1: 6400-6403 [PMID:17946369] [PMC free article] [PubMed] [Google Scholar]

- [19] Zao J.K., Mei-Ying Wang, Peihuan Tsai, Liu J.W.S., "Smart Phone Based Medicine In-take Scheduler, Reminder and Monitor", IEEE e-Health Networking Applications and Services (Healthcom), 2010
- [20] Ibrahim Adabara | Master of Science in Information Technology | Kampala International University (KIU), Kampala | Electrical Telecommunication and Computer Engineering. Available from: https://www.researchgate.net/profile/Ibrahim_Adabara2 [Accessed 29 November 2019].

BIOGRAPHIES



WALEED HUMAID

Student (Electronic and telecommunication engineering), University of the west of England, Muscat, Oman