

Developing a System for Reducing the Turning Radius of a Car

Pratik Zadafiya¹, Niravkumar Kapuriya², Chintan Vaghasiya³,
Nikunj Kumar Vaghasiya⁴, Jaimin Vaghasiya⁵

^{1,2,3,4}B.Tech., Mechanical, Chhotubhai Gopalbhai Patel Institute of Technology, Bardoli, Surat, India

⁵B.Tech., Automobile, Chhotubhai Gopalbhai Patel Institute of Technology, Bardoli, Surat, India

Abstract - The increasing prospect of electric drive vehicles has led many different control schemes to apply on the driving system. In this paper, differential speed steering which does not use traditional steering mechanism is studied on a four-wheel-driving vehicle. By comparison with the traditional Ackerman-steered vehicle, differential-steered method showed its advantage on the simple structure. Since the steering performance is just related with the velocities of four wheels, the strategy of differential speed on each motor is the major challenge. With the analysis of kinematic model of the vehicle, the relation between the turning behavior and the wheel parameters are investigated. A steering speed control method is proposed to get a steady turning performance during the acceleration or deceleration. The control strategy is implemented in a simulation to verify its rationality.

Key Words: Reducing turning radius, Differential-steered, turning behaviour, kinematic model

1. INTRODUCTION

Four wheel steering is a method developed in automobile industry for the effective turning of the vehicle and to increase the maneuverability. In a typical front wheel steering system the rear wheels do not turn in the direction of the curve and thus curb on the efficiency of the steering. In four wheels steering the rear wheels turn with the front wheels thus increasing the efficiency of the vehicle. The direction of steering the rear wheels relative to the front wheels depends on the operating conditions. At low speed wheel movement is pronounced, so that rear wheels are steered in the opposite direction to that of front wheels. At high speed, when steering adjustments are stable, the front wheels and the rear wheels turn in the same direction.

In present, there are four steering wheel configurations as follows:

1. Two Wheel Steer: In two wheel steering system, front wheel takes turn while the rear wheels are restricted to turn and follow the front wheels.

2. Four wheel steer: In four wheel steering system, front as well as rear wheels are turn but in opposite direction as that of front wheel.

3. Crab steer: In crab steering system, all the wheels are turn in same direction.

4. Zero turn steer: in zero turn steering system, the angle of wheel is so set that, the vehicle moves in a circle of zero radiuses.

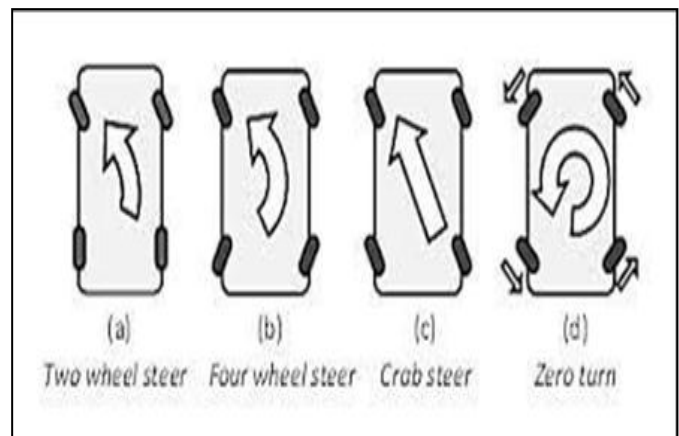

Fig -1: Four Steering Wheel Configurations

1.1 PROBLEM DEFINITION AND OBJECTIVES

• PROBLEM DEFINITION

A two wheel steering system has a bigger turning radius while in four wheels steering system has smaller. In two wheels steering system only front wheels are turning in left/right direction hence there is a bigger turning radius to turn a vehicle. In four wheel steering system, front wheels are turn in left direction while rear wheels are turn in right direction hence there is reduced in turning radius by some angle.

• OBJECTIVES

Zero turning radius of a vehicle implies the vehicle rotating about an axis passing through the centre of gravity of vehicle rather than describing a circular path as in conventional turning, i.e. the vehicle turning at the same place, where it is standing. No extra space is required to turn the vehicle. So, vehicle can be turned in the space equal to the length of vehicle itself. Zero turning radiuses exists in heavy earth mover, like excavator, as shown in Fig. 3, which consists of two parts, i.e. the upper part, cabin and boom/jaw and lower part, crawler chain.



Fig.- 2: Heavy Earth Mover

1.2 WORKING PRINCIPLE OF ZERO TURNING RADIUS CAR

- Ackerman Steering Mechanism

With perfect Ackermann, at any angle of steering, the perpendicular line through the center point of all the wheels will meet at a common point. But this may be difficult to arrange in practice with simple linkages. Hence, modern cars do not use pure Ackermann steering, partly because it ignores important dynamic and compliant effects, but the principle is sound for low speed manoeuvres.

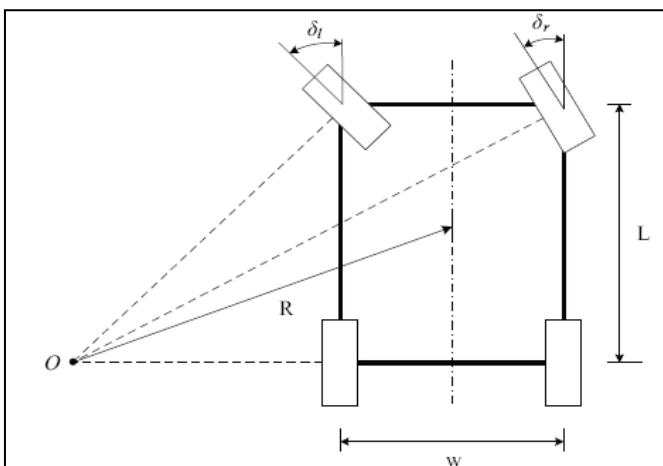

Fig.- 3: Ackerman steering

- Turning Radius

The turning radius or turning circle of a vehicle is the diameter of the smallest circular turn (i.e. U-turn) that the vehicle is capable of making.

- Under Steer

When the slip angle of front wheels is greater than slip angle of rear wheels vehicle under steers. Thus the vehicle goes out of the circle of steering. Most vehicle manufacturers set the vehicle profile with some under steer.

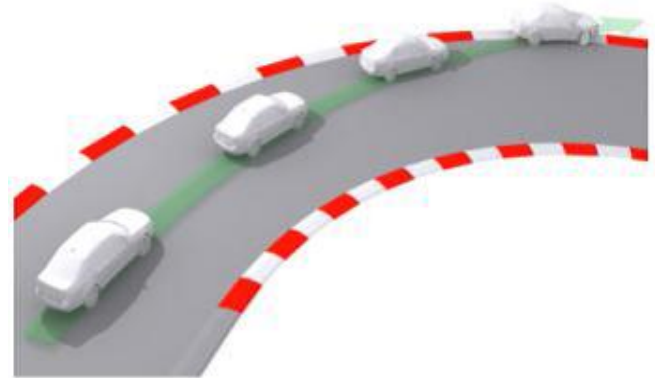

Fig.- 4: under Steer

- Over Steer

Over steer is defined when the slip angle of front wheel is less than the slip angle of rear wheel. This makes the vehicle move inside the circle of steer. This is a far dangerous situation than under steer.

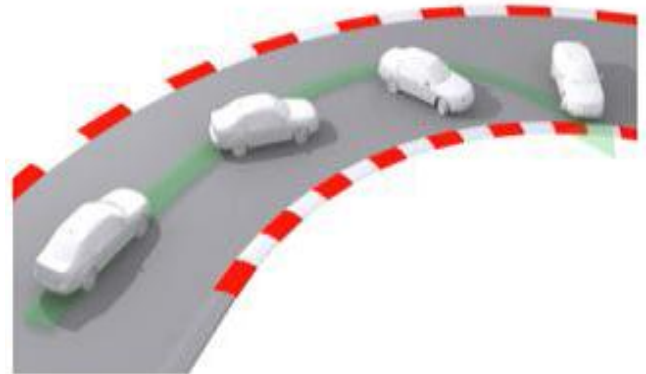

Fig.- 5: Over Steer

- Counter Steer

Counter-steering can be defined as when the slip angle of front wheels is equal to slip angle of rear wheel. The vehicle follows the line with utmost stability.

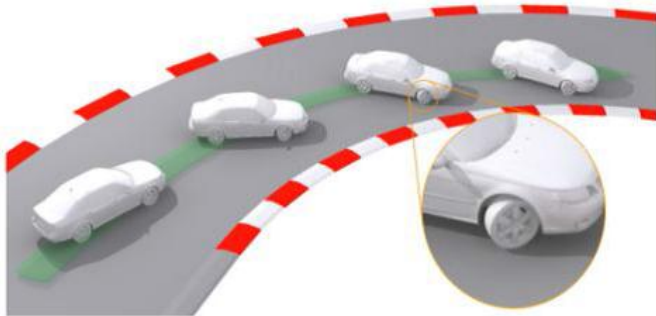

Fig.- 6: Counter Steer

1.3 ADVANTAGES OF ZERO TURNING RADIUS OF CAR

- **Superior cornering stability:**

The vehicle cornering behavior becomes more stable and controllable at high speed as well as on wet slippery road surfaces.

- **Improved steering response and precision:**

The vehicle response to steering input becomes quicker and more precise throughout the vehicle enter speed range.

- **High speed straight line stability:**

The vehicle's straight -line stability at high speed is improved. Negative effects of road irregularities and crosswinds on the vehicles stability are minimized.

- **Improved rapid lane-changing manoeuvres:**

This is stability in lane changing at high speed is improved. In high speed type operation become easier. The vehicle is less likely to go into a spin. Even in situations in which the driver must make a sudden and relatively large change of direction.

- **Smaller turning radius:**

By steering the rear wheels in the duration opposite the front wheels at low speed, the vehicle's turning circle is greatly reduced. Therefore, vehicle manoeuvring on narrow roads and during parking become easier.

- **Controlling:**

Computer-controlled Quadra steer can be switched on and off and has an effective trailer towing mode.

1.4 DISADVANTAGES OF ZERO TURNING RADIUS OF CAR

- The effect that it produces is not felt significantly at low speed or in commercial cars but in heavy vehicles like trucks and towing vans it provides significant lane changing and low speed manoeuvrability. Its mechanism is extensively complex. Although many designs have been brought forward so far, none has the right combination of simple design, low maintenance with low cost.
- The 4 wheel steering, due to construction of many new components, the system becomes more expensive.
- The system includes as many components (especially electronically) there is always a chance to get any of the part inactive, thus the system become in operative.

2 BASIC GEOMETRY

The basic aim of steering is to ensure that the wheels are pointing in the desired directions. This is typically achieved by a series of linkages, rods, pivots and gears. One of the fundamental concepts is that of caster angle - each wheel is steered with a pivot point ahead of the wheel; this makes the steering tend to be self-centring towards the direction of travel. The steering linkages connecting the steering box and the wheels usually conforms to a variation of Ackermann steering geometry, to account for the fact that in a turn, the inner wheel is actually travelling a path of smaller radius than the outer wheel, so that the degree of toe suitable for driving in a straight path is not suitable for turns. The angle the wheels make with the vertical plane also influences steering dynamics (see camber angle) as do the tires. Many modern cars use rack and pinion steering mechanisms, where the steering wheel turns the pinion gear; the pinion moves the rack, which is a linear gear that meshes with the pinion, converting circular motion into linear motion along the transverse axis of the car (side to side motion). This motion applies steering torque to the swivel pin ball joints that replaced previously used kingpins of the stub axle of the steered wheels via tie rods and a short lever arm called the steering arm.



Fig.- 7: Worm and Worm Gear

The rack and pinion design has the advantages of a large degree of feedback and direct steering "feel". A disadvantage is that it is not adjustable, so that when it does wear and develop lash, the only cure is replacement.

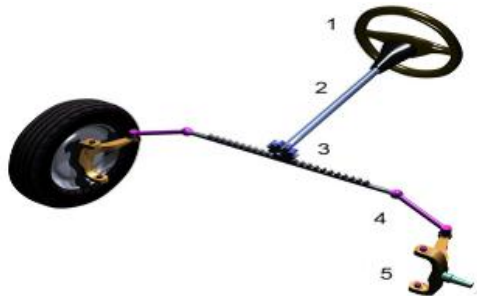

Fig.- 8: Rack and pinion steering mechanism

1. Steering wheel,
2. Steering column,
3. Rack and Pinion,
4. Tie rods,
5. Kingpins

2.1 ABOUT ZERO TURNING RADIUS OF CAR

The turning radius of a vehicle is the radius of the smallest circular turn (i.e. U-turn) that the vehicle is capable of making. The term turning radius is a technical term that has become popular automotive jargon. In the jargon sense, it is commonly used to mean the full diameter of the smallest circle, but in technical usage the turning radius still is used to denote the radius. The less ambiguous term turning circle avoids the mistaken jargon use of the word 'radiuses'. As an example, Motor Trend refers to a curb-to-curb turning circle of a 2008 Cadillac CTS as 35.5 feet (10.82 m). But the terminology is not yet settled. The AutoChannel.com refers to turning radius of the same car as 35.5 feet (10.82 m). It is often used as a generalized term rather than a numerical figure. For example, a vehicle with a very small turning circle may be described as having a "tight turning radius".

2.2 CONDITION FOR TRUE ROLLING

While tackling a turn, the condition of perfect rolling motion will be satisfied if all the four wheel axes when projected at one point called the instantaneous centre, and when the following equation is satisfied:

$$\cot \phi - \cot \theta = c/b$$

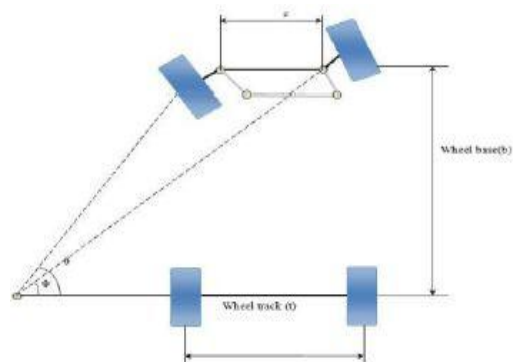

Fig.- 9 True Rolling Condition

2.3 SLOW AND HIGH SPEED MODES

At Slow Speeds rear wheels turn in direction opposite to that of front wheels. This mode is used for navigating through hilly areas and in congested city where better cornering is required for U turn and tight streets with low turning circle which can be reduced as shown in Fig 2.4.

Table -1: Sample Table format



Fig.- 10 Slow Speed

At High Speeds, turning the rear wheels through an angle opposite to front wheels might lead to vehicle instability and is thus unsuitable. Hence the rear wheels are turned in the same direction of front wheels in four-wheel steering systems. This is shown in Fig 2.5.



Fig.-11 High Speed

2.4 IN-PHASE AND COUNTER-PHASE STEERING

The 4 wheel steering system performs two distinct operations: in- phase steering, whereby the rear wheels are turned in the same direction as the front wheels, and counter phase steering, whereby the rear wheels are turned in the opposite direction. The 4 wheel steering system is effective in the following situations:

- Lane Changes
- Gentle Curves
- Junctions
- Narrow Roads
- U-Turns
- Parallel Parking

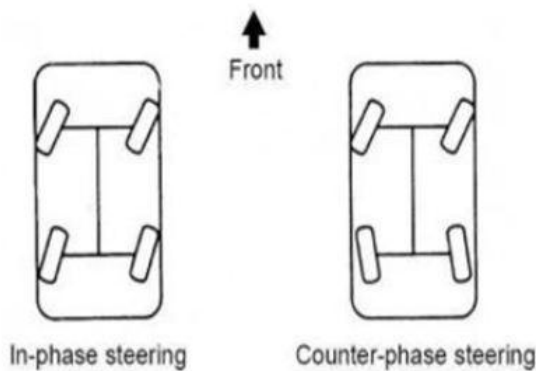

Fig.- 12 In-Phase and Counter-Phase Steering

2.5 FOUR WHEEL STEERING SYSTEM

The Four wheels steering system can be used in two modes:

A) Crab turning radius mode:

In the Crab turning radius mode, where in all wheels turn in same direction. This system is used at high speeds. This helps reduced centrifugal force on turns and prevents skidding of vehicle.

B) Reduced turning radius mode:

In the Reduced turning radius mode, where in pair of wheels turn in alter direction. This system is used at low speeds. This enables the vehicle to turn in minimal possible space.

2.6. DIFFERENTIAL SPEED STEERING

A. Traditional Steering Method

According to the Ackerman model of steering when vehicle is running in a low speed, as be shown in Fig. We define L is the distance between front and rear wheel, W is the track width

of the vehicle, δ is average steering angle of two front wheels.

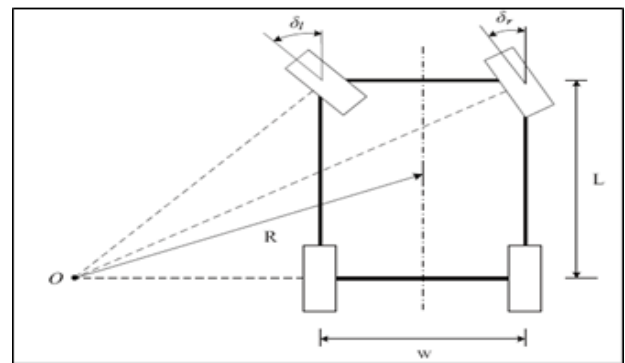

Fig.-13 Traditional Steering Method

B. Differential Speed Steering

Steering by differential speeds between the left and right wheels is widely used in the motion control of mobile robots. Benefited from the in-wheel-motor, four-wheel independent driving vehicle is suitable to take a similar control method. The motion direction of this kind of electric vehicle can be changed by rotating the left and right side wheels at different velocities, which is called differential speed steering. This steering mechanism makes the vehicle mechanically robust and simple which provides a new way to realize the motion control of electric vehicle.

2.7 MODEL OF FOUR WHEELS STEERING SYSTEM

Four wheels steering system is as shown in figure below. Four steering motors are used to drive a vehicle at any direction. This model is works on 12V DC battery and a DPDT switch. A worm and worm wheel gearbox is manufactured and it placed on chassis where each wheel is moved in each direction.

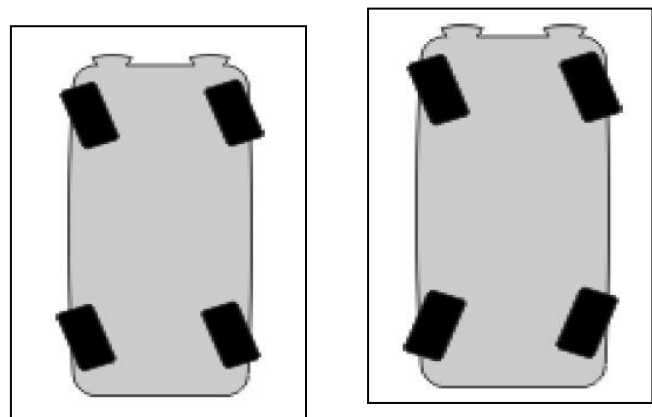

Fig.- 14: Crab Turning Radius Mode and Reduced Turning Radius Mode

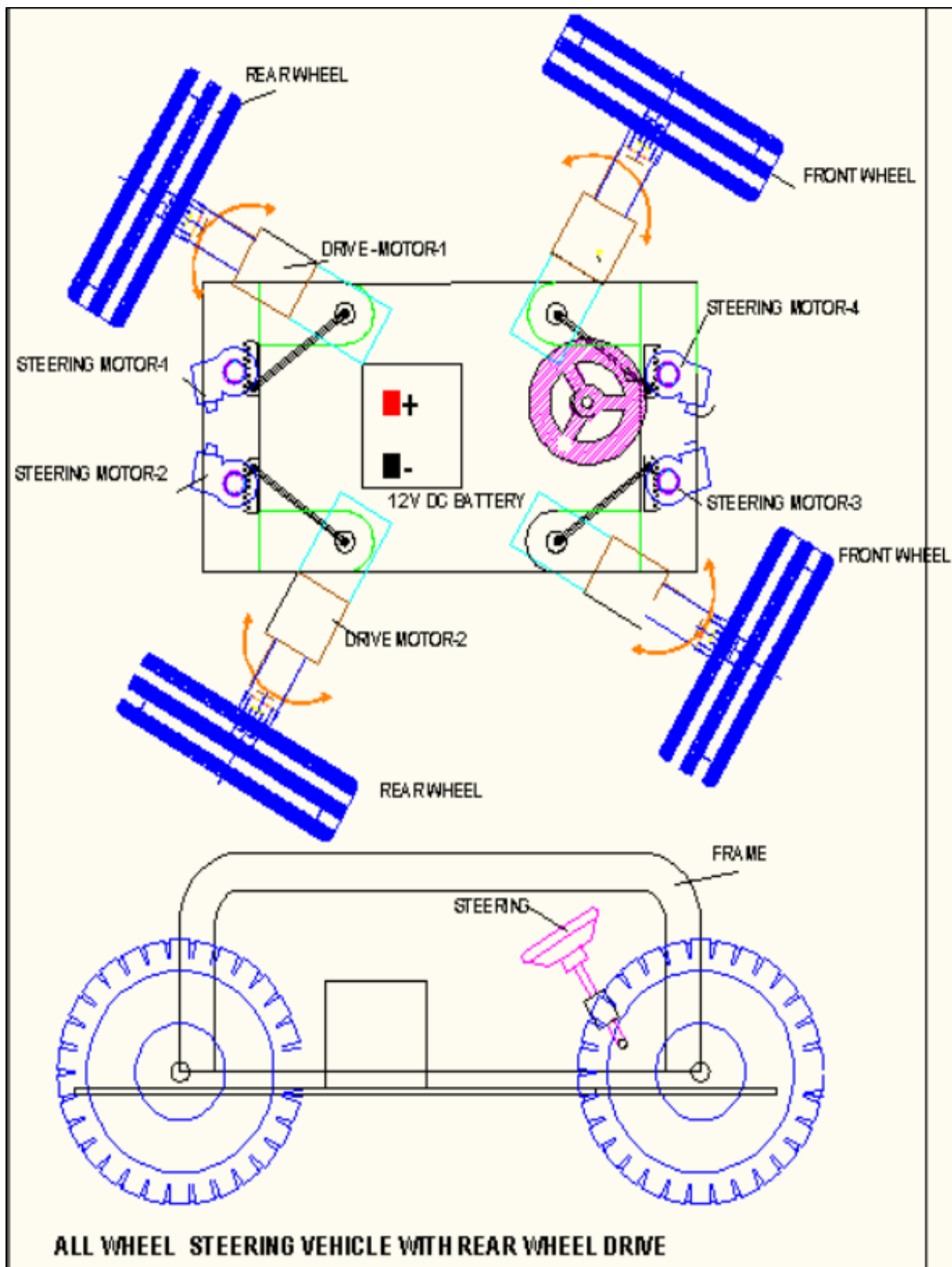

Fig.-15: Steering Wheel and mechanism of car

2.8 FOUR WHEEL STEERING

Four-wheel steering, also called rear-wheel steering or all-wheel steering, provides a means to actively steer the rear wheels during turning manoeuvres. It should not be confused with four-wheel drive in which all four wheels of a vehicle are powered. It improves handling and helps the vehicle make tighter turns. Production-built cars tend to under steer or, in few instances, over steer. If a car could automatically compensate for an under steer /over steer problem, the driver would enjoy nearly neutral steering under varying conditions. 4 wheel steering is a serious effort on the part of automotive design engineers to provide near-neutral steering.

The front wheels do most of the steering. Rear wheel turning is generally limited to half during an opposite direction turn. When both the front and rear wheels steer toward the same direction, they are said to be in phase and this produces a kind of sideways movement of the car at low speeds. When the front and rear wheels are steered in opposite direction, this is called anti-phase, counter-phase or opposite-phase and it produces a sharper, tighter turn. This project aims at developing a 4 Wheel Steering System which would cater to the needs of people. This system is employed to improve steering response, increase vehicle stability while manoeuvring at high speed, or to decrease turning radius at low speed.

The concept is simple. Rather than controlling a car solely by the angle at which the front tires meet the road the method used by wheeled vehicles since the horse-drawn carriage, four-wheel steering turns the wheels simultaneously at both ends of the car. The idea is intuitively appealing to any city driver who has ever pulled up to a too-short parking space and wished he could point all four tires toward the curb and crab right in. Not so easy. For starters, the rear wheels of a four-wheel-steer car do not always turn in tandem with the front wheels. Depending on the speed of the car, the rear wheels may turn in the same direction (same-side steering) as the front wheels, or in the opposite direction (counter steering).

Most of the new four-wheel-steer autos are capable of both counter steering and same-side steering. In sharp, slow-speed turns, counter steering can shave a full yard off a standard sedan's turning radius. At high speeds, however, counter steering can make a car dangerously unstable, while same-side steering actually improves the ride. The difference comes from the dynamics of high-speed motoring. When a driver travelling at highway speeds turns the wheel of a conventional, two-wheel steering car, the front tires immediately begin to pivot and the car's forward momentum generates a powerful sideways or cornering force at the front axle.

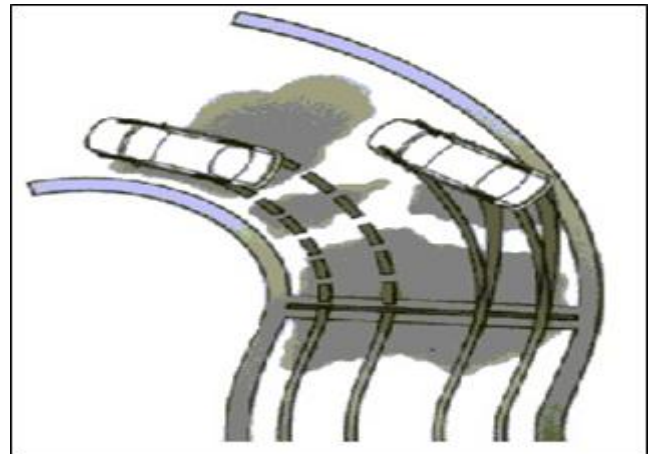

Fig.- 16: Four Wheel v/s two wheel steering

Rear tires, however, have to wait until the car has actually started its turn before they begin to generate a corresponding force at the rear axle. That is why a car with two-wheel steering fishtails during lane changes; the back end is trying to catch up to the front. In extreme cases, or under slippery conditions, the rear of the car may fishtail out of control. In a four-wheel-steer car, this high-speed sway can be damped or even eliminated through the use of same-side steering. When the rear wheels are turned at the same time and in the same direction as the front wheels, the back end turns with the front, and the cornering forces occur at both axles simultaneously. The car slides smoothly to the side without sway or fishtail.

3 COMPONENTS AND WORKING

3.1 Components

➤ Primary Components

- Vehicle speed sensors Interpret speedometer shelf revolutions and send signal to the electronic computer unit. Two sensors, one within the speedometer and the other at the transmission output, are used to crosscheck the other for accuracy and failsafe measures.
- Steering phase control unit conveys to the power steering cylinder booster valve the direction and stroke of rear wheel steering by the combined movement of the control yoke angle and bevel gear revolutions.
- Electric stepper motor Performs altering of the yoke angle and bevel gear phasing.
- Rear steering shaft Transmits front wheel steering angle by turning the small bevel gear in the steering phase control unit, which rotates the main bevel gear in the assembly.
- Control valve Feeds hydraulic pressure to the steering actuator, according to the phase and stroke required for appropriate rear wheel steering.
- Hydraulic power cylinder operates the output rod by hydraulic pressure and steers the rear wheels. It locks the rear wheels in a "neutral"(straightforward) position

with the centering lock spring, which is activated by a solenoid valve in case of failure to ensure a normal 2WS.

- Function for the vehicle hydraulic pump provides hydraulic pressure to both the front and rear steering systems.

➤ Steering Phase Control Unit

- The steering phase control unit alters the direction and degree of rear wheel steering. It consists of a stepper motor that controls the rear steering ratio, a control yoke, a swing arm, a main bevel gear engaged to the rear steering shaft via a small bevel gear, and a control rod connected to the control valve.

➤ It operates:

- Opposite phase (direction) steering under 35km/h (22mph).
- Control Yoke is at an angle activated by the stepper motor.
- Front wheels are steered to the right. The small bevel gear is rotated in direction X by the rotation of the rear steering shaft. The small bevel gear, in turn, rotates the main bevel gear.
- Rotation of the main bevel gear causes movement of the control rod toward the control valve.
- Input rod of the control valve is pushed to the right, according to the degree of the control rod's movement (determined by the disposition of the swing arm), which is positioned to move in an upward direction, to the right. The rear wheels are thus steered to the left, in an opposite direction to the front wheels. As the angle of the control yoke is increased in direction A as vehicle speed decreases, the rear to front steering ratio proportionately increases and the vehicle's steering lock tightens.
- Same phase (direction) over 35km/h (22mph). The operation of this phase is the reverse of the opposite phase one, because the control yoke is angled toward "positive" in this vehicle speed range, as illustrated. The phasing of the swing arm, yoke rod and bevel gear steers the rear wheels toward the right-the same direction as the front wheels.
- Neutral phase, at 35km/h (22mph) the control yoke's angle is horizontal (neutral). Thus, the input rod is not affected, even if the control rod is moved with the rotation of the bevel gear unit. As a result, the rear wheels are not steered in this mode.

3.2 Working Mechanism

- Consists of a rack-and-pinion front steering system that is hydraulically assisted by a twin tandem pump main power source.

- The rear wheel steering mechanism is also hydraulically assisted by the main pump and electronically controlled - according to the front steering angle and vehicle speed.
- The rear steering shaft extends from the rack bar of the front steering gear assembly to the rear steering-phase control unit.
- The rear steering system is comprised of the input end of the rear steering shaft, vehicle speed sensors, a steering-phase control unit (determining direction and degree), a power cylinder and an output rod.
- A centering lock spring is incorporated, which locks the rear system in a neutral (straightforward) position in the event of hydraulic failure. Additionally, a solenoid valve that disengages hydraulic assist (thereby activating the centering lock spring) in case of an electrical failure is included.
- The 4 wheel steering system varies the phase and ratio of the rear-wheel steering to the front wheels, according to the vehicle speed.

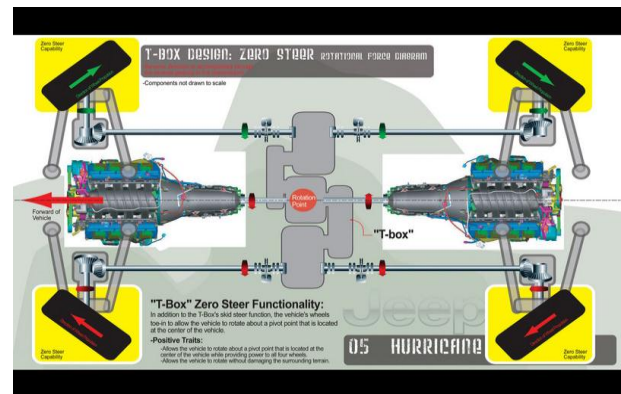

Fig.- 17: Working Mechanism

- It steers the rear wheels toward the opposite phase (direction) of the front wheel during speeds less than 35km/h (22mph) for a tighter turn and "neutralizes" them (to a straightforward direction, as in a conventional two-wheel steering principle) at 35km/h (22mph).
- Above the speed of 35 km/h, the system steers toward the same phase-direction as the front wheels, thereby generating an increased cornering force for stability.
- The maximum steering angle of the rear wheels extends 10 degrees.

4 Conclusions

Automobile industry is very fast growing industry and day-by-days developing the new technologies/systems that are mainly related to safety, ergonomics and efficient drive. The developed model was tested in various conditions and effectively reduced the turning radius to its minimum in the developed model. The reduced turning circle diameter (nearly about zero) has lots of advantages in daily life, such as

- Better parking at home in narrow space and at multiplexes.
- Easy removal of vehicle from the traffic jams.
- Easy changing the punctured tire.
- Turning back at narrow roads.
- Use in service and maintenance etc. The system can be developed using the hydraulic system. This can give fast response and less space is required. The developed model is recommended for inclusion in the cars.

- [7] <http://auto.howstuffworks.com/jeep-hurricane2.htm>
- [8] R. S. Khurmi, J.K. Gupta, "A Text Book Of Machine Design, Eurasia Publishing House Pvt. Ltd.", First Multi Color Edition, Pp 576-586, 658-679, 1037-1040, 2005.

5. Future Scope

Having studied how 4 wheel steering has an effect on the vehicle's stability and driver maneuverability, we now look at what the future will present us with. The successful implementation of 4 Wheel Steering using mechanical linkages & single actuator will result in the development of a vehicle with maximum driver maneuverability, uncompressed static stability, front and rear tracking, vehicular stability at high speed lane changing, smaller turning radius and improved parking assistance. Furthermore, the following system does not limit itself to the benchmark used in this project, but can be implemented over a wide range of automobiles, typically from hatchbacks to trucks. This coupled with an overhead cost just shy of Rs. 15,000 provides one of the most economical steering systems for improved maneuverability and drivers' ease of access. With concepts such as "ZERO TURN" drive as used in "Tata Pixel" and "360o Turning" used in "Jeep Hurricane", when added to this system, it will further improve maneuverability and driver's ease of access.

6. REFERENCES

- [1] Atinder Singh "Ackerman Steering Formula Derivation", <http://www.scribd.com/doc/58682411/Ackerman-SteeringFormula-Derivation>, June 2011.
- [2] K. Lohith, Dr. S. R. Shankapal, M. H. Monish Gowda, "DEVELOPMENT OF FOUR WHEEL STEERING SYSTEM FOR A CAR", Volume 12, Issue 1, April 2013.
- [3] Four wheel steering report, <http://www.scribd.com/doc/34677964/Four-WheelSteering-report>, Retrieved on 13th Sep 2012.
- [4] Er. Amitesh Kumar, Dr. Dinesh N. Kambale ,Zero Turn Four Wheel Steering system, Dec. 2014
- [5] B.L. Salvi, J.K. Maherchandani, Dr. B.P. Nandwana, Developing a system for reducing the turning Radius of a Car, March 2012.
- [6] V.B. Bhandari, "Design of Machine Element Third Edition" McGraw Hill Education India Pvt. Ltd. Volume -, 11th Edition, 2013.