

Robot Development for Multisensory Inspection System for Low-Diameter Pipes in Thermal Power Plant Boilers

Ricciotti, A. C. D.¹, Ricciotti, V. B. S. D.², Militão, J. S. L. T.³, Steiner, F. M.⁴, Militão, G. H.⁵, Rodrigues, T.P.⁶

^{1,2}Professor, Dept. of Electrical Engineering, Federal University of Rondônia, Brazil

³Professor, Dept. of Chemical, Federal University of Rondônia, Brazil

⁴R & D Manager of the EDF Norte Fluminense Thermal Power Plant, Rio de Janeiro, Brazil

⁵GPTI, Porto Velho, Brazil

⁶Jordan Engineering, Rio de Janeiro, Brazil

Abstract - This paper presents the development of a robot with an inspection system using different sensors mounted to allow all boiler tubes with water walls to be reached. The equipment is designed for non-destructive invasive inspection of manifolds and pipes of varying diameters in aquatubular boilers. The prototype is installed at one end of the boiler manifold, and the equipment performs a full collector inspection by inserting probes with multiple sensors. The data collected by the sensors is related to the position of the pipe measurements, varying according to the pipe location. With data treatment, it can determine the precise adjustments for the evaluation of the tubes. Therefore, the inspection robot with an integrated data capture system offers advantages in terms of requirements, robustness, and ease of operation compared to plant inspection methods.

Key Words: Boiler inspection; Pipe Inspection Sensors.

1. INTRODUCTION

Inspection of equipment in industrial plants involves compliance with relevant legislation and reduction of operational risks. Brazilian law is the Regulatory Standard of the Ministry of Labor - NR13 - "Safety Regulation for Boilers and Pressure Vessels," which defines deadlines for the inspection of such equipment. The concepts and assumptions of Risk-Based Inspection are expressed in Brazil by standard API 581. The norm presupposes probabilistic analyzes and consequences of failures. In this case, the periodicity of inspections becomes a variable between the results and the probability of occurrence [1].

The need to apply region-specific inspection plans to a boiler has the most precise and individualized advantage of weaknesses. It offers the option of investing in inspection in more sensitive areas, with lower costs in lower-risk regions [2], [3].

Boiler inspection is fundamental for assessing the level of deterioration of the pipes and especially the so-called hot zones. Scheduled monitoring decreases the likelihood of outages and, consequently, unscheduled

system shutdowns. The main parameters used are the degree of metallurgical degradation and the corrosion of the pipes, which are the leading causes of ruptures. Piping evaluation is usually destructive, where samples are taken for visual examination, metallographic analysis, and creep tests.

These methods imply physical access difficulties, limiting the obtaining of samples and a long delay in the return of the analyzes, as well as the maintenance cost and the system shutdown itself. A useful parameter for assessing the degree of impairment and its thermal conductivity is the value of the thickness of the magnetite layer formed on the inner wall of the tubes.

Boiler designs involve predictions of the interaction of the various components and products involved. Changes in operating procedures or materials will undoubtedly lead to unforeseen design. Power pump failures lead to overheating during service life. Non-standard water results in corrosion problems, material failures, welding, or even design errors infrequently. Thus, "accidents" or unplanned shutdowns depend on the proper functioning of the operational monitoring system and the ability to detect possible failures, combined with the agility of operation and maintenance quality, both to minimize the intensity of damage and to reduce its consequences on boiler performance.

Large boilers built in Brazil are designed based on standards from other countries. On the other hand, design variations for fuel compositions can lead to difficulties in combustion control. What implies problems such as the optimal height of the radiation flame temperature. Do not match the design of the water walls, phase changes in the water wall at different design heights or severe erosion, and even corrosion problems would occur in the original designs of the same severity [5].

The literature cites several possible boiler damages, among them, the most exciting and complex, is the corrosion caused by the Flow Accelerated Corrosion (FAC). Flow-accelerated corrosion differs from ordinary

erosion and can be classified as a type of electrochemical corrosion combined with a dissolution and mass transfer process. The literature presents studies on the problem. It suggests the reasons for its maximum occurrence at a specific temperature range (150 - 170 ° C), as well as its increase due to inversion in the solubility that occurs with pH, at temperatures around 300 ° C [6].

In the face of boiler inspection problems, a robot for non-destructive invasive inspection of manifolds and pipes of various diameters in aquatubular boilers was developed.

2. ROBOT DESIGN

The techniques used for the development of the inspection robot involved the use of 3D printers with ABS filaments – Figure 1. Considering that the tube boiler arrangement and the configuration of the boiler in this study is the model in reduce scale that existent in EDF. The robot was designed with treadmills for better traction. NEMA 17 17HS2408 stepper motors were used, two per belt.

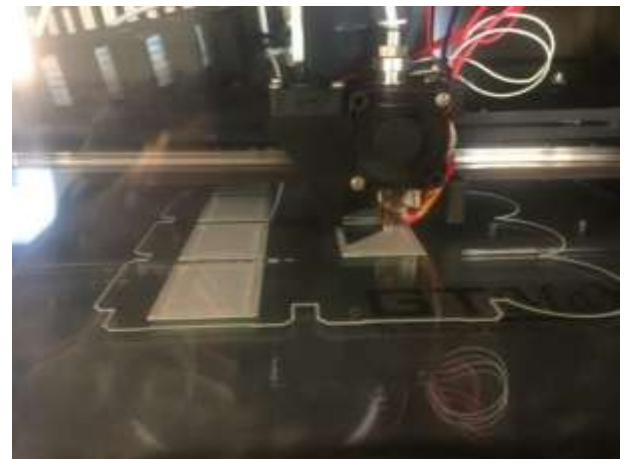

Figure 3 - Printing of propulsion engine mounting boxes

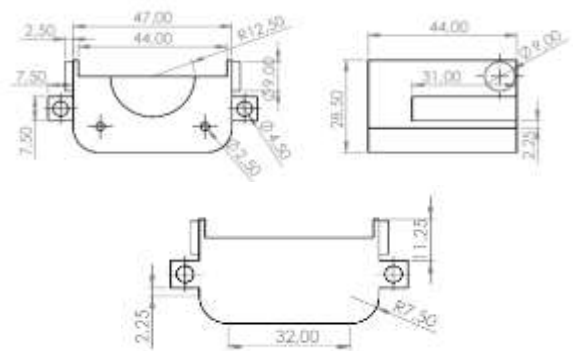

Figure 4 - Propulsion box mounting dimensions.



Figure 1 - Overview of 3D Prototyping Machines in Robot Parts Construction Operation.

The following figures show the steps of the inspector robot design.

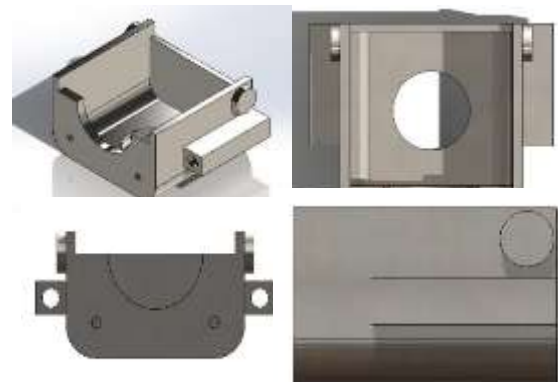

Figure 5 - Design of parts with CAD Software

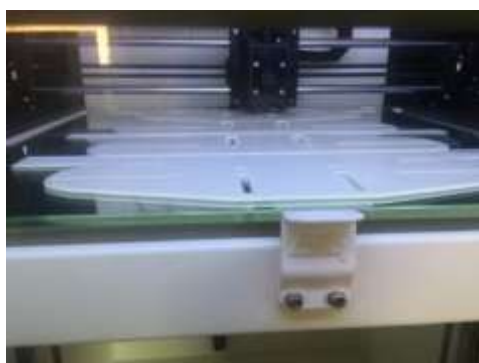

Figure 2 - Side Covers Printing.



Figure 6 - Printed Propulsion Engine Support Boxes.

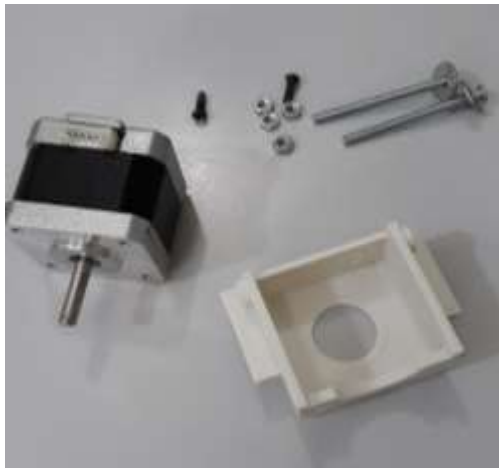

Figure 7 - Engine mounting box, engine, and mounting bolts.

Important to highlight the details of the originality of the position of the propulsion engines, which were installed inside the rails.



Figure 8 - Motors installed in their brackets and fixed to the side support bracket of the gears.



Figure 9 - Drive gears installed surrounding the engines.

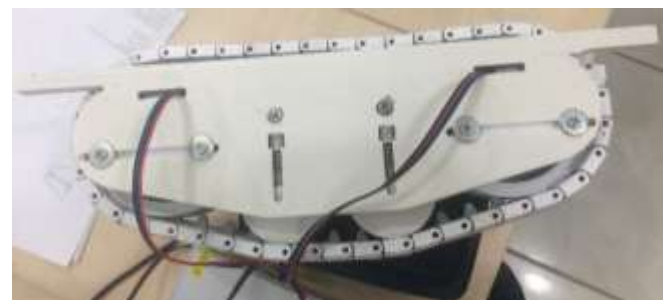

Figure 10 - Mounted traction system

The torque of the selected stepper motors was calculated by the equations:

$$N_G = \frac{60v}{D\pi} [RPM] \quad (1)$$

$$i = \frac{f}{N_G} \quad (2)$$

$$T_{eu} = \frac{F_B D}{2} [N.m] \quad (3)$$

$$T_M = \frac{T_{eu}}{i \cdot \eta} \quad (4)$$

3. Instrumentation Module

The instrumentation module is used for navigation and monitoring tasks and is responsible for making measurements inside the pipeline network. And in this module are located elements such as sensors, cameras. The data from this module is used for the correct locomotion of the robot inside the boiler. On the other hand, the purpose of monitoring the inside of the pipe is avoiding accidents with the robot.

4. Sensing

The use of sensors in pipeline inspection robots is essential due to the need for information such as:

- Robot location data in the pipe;
- Detection of obstacles or obstructions inside the duct;
- Monitoring of the environment concerned.

For this, the robotic inspection system has at least one acting sensor such as obstacle sensors, infrared or ultrasound-guided proximity sensors, and encoders that can be attached to the wheels of the automated system. Of the ultrasound inspection systems, the Internal Rotary Inspection System (IRIS) is the most applicable for internal inspection.

5. Control system

The Control Module is responsible for:

- Motion control of the robotic system;
- Communication management of the robotic system with a ground station.

This control system consists basically of a microcontroller to control the robot movements, integrated to the traction module motor circuits, besides supporting signal converters and sensors. The program implemented in the controller was developed in Labview.

6. Motion control

Motion control of the robotic duct inspection system is associated with the control of the operation of your motor. The motor is controlled by computer programs implemented in the control system microcontroller, having as reference data sent from the sensors located in the instrumentation module.

7. Prototype Testing

The equipment is designed for non-destructive invasive inspection of manifolds and pipes of varying diameters in aquatubular boilers.

Once installed at the collector inlet, the equipment moves inside the collector (lower or upper) conducting a probe with a sensor and, in each row of tubes, a rotating device allows its alignment with the inlet of the pipes, introducing the sensor, which takes the readings and sends the data to an external acquisition system.

The data collected is related to the position of the measurements in the pipeline, i.e., scans as a function of the pipeline location, which allows localized action when necessary.



Figure 11 - Equipment inside the test tube without and with motor.

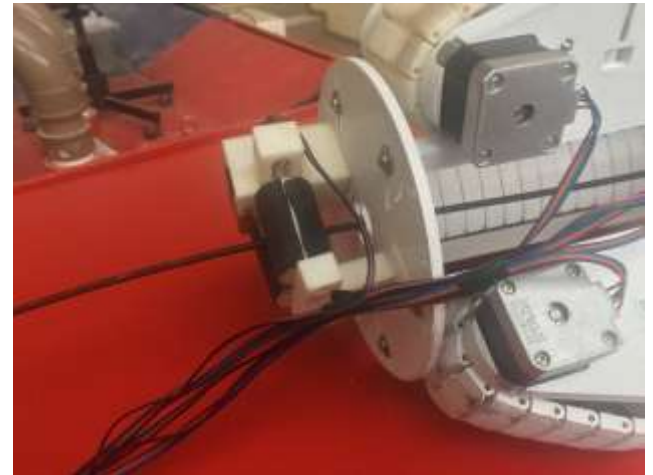

Figure 12 - Sensor Cable Feeder Detail.

In the first test the inspection robot moved within the boiler tube at a speed of 19 m / s.

The second test the inspection robot was able to move vertically without sliding down.

8. Conclusions

This paper proposed a robot design capable of operating on boiler tubes for non-destructive invasive inspection of manifolds and pipes of varying diameters in aquatubular boilers.

Sensors, motors, and best control strategy analyzes were performed to ensure that the prototype is fully functional. The tests were presented at the collector inlet. The equipment moved inside the collector (lower or upper) conducting a probe with a sensor and, in each row of tubes, a rotating device made possible its alignment with the entrance of the pipes, introducing the sensor, which took the readings and sent the data to an external acquisition system. The data collected is related to the position of the measurements in the pipe. The scans are in function of the location in the tube of the boiler, which allows a localized action.

From the overall test result, it can be concluded that the inspection robot meets the design requirements and is fully functional, although some limitations are observed during the test.

ACKNOWLEDGEMENT





The authors thank the companies EDF Norte Fluminense S.A., Jordão Consulting, GPTI, and Technology and Innovation Research Group. Project Code 00678-0117/2017

REFERENCES

- [1] M.Z. Baharuddin, J. Md Saad, A. Anuar, I.N. Ismail, N.M. Hassan Basri, N.S. Roslin, S.S. Kaja Mohideen, M.F. Abdul Jalal and K.S. Mohamed Sahari, "Robot for Boiler Header Inspection "LS-01"", Procedia Engineering, vol. 41, 2012, pp. 1483-1489.
- [2] A. Anuar, N.S. Roslin, K.S. Mohamed Sahari and M.A. Aziz, "Inspection Robot for Parallel Entry Boiler Header Pipe." In Soft Computing in Advanced Robotics, Springer International Publishing, 2014, pp. 105-114.
- [3] S. Park, H. D. Jeong, Z. S. Lim," Development of Mobile Robot Systems for Automatic Diagnosis of Boiler Tubes in Fossil Power Plants and Large Size Pipelines," Proc. IEEE Intl. Conference on Intelligent Robots and Systems, October 2002.
- [4] S. Park, H. D. Jeong, Z. S. Lim," Design of a Mobile Robot System for Automatic Integrity Evaluation of Large Size Reservoirs and Pipelines in Industrial Fields," Proc. IEEE Intl. Conference on Intelligent Robots and Systems, October 2003.
- [5] F. Rochat, P. Schoeneich, O. Nguyen, H. Bleuler and F. Mondada, "TUBULO II: Magnetic Climbing Inchworm for Inspection of Boiler Tubes", Proc. Intl. Conference on Climbing and Walking Robots and the Support Technologies for Mobile Machines, September 2011.
- [6] X. Lu, R. Qiu, G. Liu and F.Huang, "The Design of an Inspection Robot for Boiler Tubes Inspection", Proc. Intl. Conference on Artificial Intelligence and Computational Intelligence, vol. 2, pp. 313-317, November 2009.

BIOGRAPHIES

	<p>Dr. Antonio Carlos Duarte Ricciotti is an electrical engineer (1988 - FEI), M.Sc. of (2006) in biomedical and automatic engineering Ph.D. (2017) in power electronics by the Federal University of Santa Maria (UFSM).</p>
---	---

	<p>Dr. Júlio Sancho Linhares Teixeira Militão is a B.Sc. in chemistry from the University of Fortaleza (1981), M.Sc. in chemistry (1988-UFCE) and Dr. in chemistry (1995-UFCE).</p>
	<p>M.Sc. Viviane Barrozo S. D. Ricciotti is an electrical engineer (2008-UFRGS), B.Sc. in Physics (1997-UFPR), B.Sc. in Mathematics (1995-Paranaense University), M.Sc. in Physics (2001-UFRGS).</p>
	<p>B.Sc. Fabio Monteiro Steiner, He holds a degree in Business Administration from Candido Mendes University (1991).</p>
	<p>Hebert Garcez Researcher and Electrical Engineer at the Federal University of Santa Catarina, with over 10 years of experience in commissioning power generating units. He worked in the commissioning of Jirau HPP, Pampa Sul HPP, among others in Brazil and South America.</p>
	<p>Pierre Rodrigues, Graduated in Electrical Engineering from the Fluminense Federal University (1994). Twenty years of experience in the electricity sector developing projects in the areas of energy efficiency, acting as instructor in specialization courses on energy efficiency, participation as author in publications on energy efficiency, management and development of research and development projects in generation companies. , transmission and distribution of energy, project management on renewable sources of electricity and coordination of the execution of commercial and industrial electrical installations. Entrepreneurial spirit, dynamism and history of success in the development and management of projects related to the electricity sector. Is managing partner of the company Jordão Engenharia.</p>