

AUTOMATIC BOTTLE FILLING AND CAPPING SYSTEM USING PLC

Dr. Pankaj Prajapati¹, Sachin Singh², Saurabh Gupta³, Shivani Srivastava⁴

¹Associate Professor, Department of Electronics and Communication Engineering, Ambalika Institute of Management and Technology, Lucknow

^{2,3,4}Research Scholar, Department of Electronics and Communication Engineering, Ambalika Institute of Management and Technology, Lucknow

Abstract - In a present world of industrialization with modernization of societies, it has now become a challenging problem to meet the demand of the people. Presently the task to obtain the output and to meet the demand is one of the adversaries in a present scenario that we need to do something to improve and to be a part of this modernization. In this project, we are implementing an "Automatic Bottle Filling and Capping" and are dedicating to the industries. In this project we are using PLC which is a brain of this entire project. The main work it will do is the filling and capping of the bottles used in industries for the various purpose such as pouring fluids (such as milk, water etc.) in a packing bottles, toxic chemical containers storing in bottles without any injuries.

The objective here will be to meet the demand and to develop the "Automatic bottle filling and capping system using PLC". The intention will be to obtain the requirement in the industries to get an excessive high percentage output and with a low power consumption to get the high accuracy. The project is developed in accordance to meet the requirements in the industrial automation. Also, since the project uses the PLC, it's maintenance is less as compared to the devices which obtains the same output but uses the controller other than PLC. [4]

The first task of the project is filling. Filling of bottles is controlled using the PLC controller which is also the brain of this project. The conveyer belt will move and shift the filled bottle with an unfilled bottle. The conveyer uses the geared d.c. motor. A sensors used at the conveyer is used to sense the amount of fluid filled in a bottle and replace the next bottle with the existing position of the bottle. The project uses less number of systems, which reduces the cost. Ladder Logic is used for the programming of the PLC. The software on which the program here will be written to run is LogixPro.[4] The next step after the filling is the capping which is configured to perform the next step of this project and is to filling the bottles. The cost of this project is very less(after installing a PLC in industries) and the implementation including the programming is very adapt. Only it requires a little skilful labor to use PLC.

Key Words: PLC, Bottle Filling, Conveyer, D.C. geared motor, Capping, Proximity sensor

INTRODUCTION:

The project is specifically to determine our objective, design based on the industrial automation and PLC is the brain of automation since it only takes the decision. As we know that to implement any project, the main components are the hardware and the software which will configure this project under working condition.

- 1) **HARDWARE DESCRIPTION:-**In order to achieve the objectives of the project, Siemens PLC SIMATICS S7(it could be any other)is used for controlling the inputs and outputs. The inputs will be given through a Switch Mode Power Supply(SMPS).The rating of SMPS is 24V DC 5Ampere.The PLC used is compact which has fixed number of inputs and outputs. In this kind of model, the CPU contains 14 digital inputs and 10 digital outputs. A diffused photoelectric sensors are used for the positioning of the bottles. A geared D.C. motor will be used for running the conveyer system and the speed of the motor should be 12V and 50RPM speed. Toggle switches are used to serve the purpose of some inputs to PLC. The cardboard is used to kept the project model on it.[5]
- 2) **SOFTWARE DESCRIPTION-**There will be five important parts in the program software used to run it and they are[5]:-
 - Functional block diagram(FBD)
 - Instruction list flow
 - Chart ladder diagram
 - Structure test
 - Flow chart

Above the all, chart ladder diagram is the most widely used language which is simple, convenient, and easily implemented to run the program (since it gives the complete flow of the program) as compare to the other languages since it is a flow of information. Ladder logic is used here for the programming of the PLC.

LITERATURE REVIEW:

In this research paper the researchers T.Kalaiselvi, R.Praveena have developed an automatic bottle, filling and capping system with the mechanism using different sensing devices[1]. Automatic Filling process for bottles to be filled simultaneously with a user defined selection for measured volume to be filled[8]. In this paper the researchers Kala Meah, Timothy Garrison, York college of Pennsylvania have worked. The students who were working in small teams and had roughly some weeks to design an automated electromechanical system that first transports three empty bottles of water, cap each bottle by covering the top with a tennis ball, and then deliver the capped and filled bottles to an area outside of the operational zone[2].

In this research paper the researcher Jaymin patel Department of Physics and Electronics of Hemachandracharya North Gujarat University, Patan had develop a bottle filling system based on certain specifications to make it usable for the industrial applications[3].

In this research paper, the researcher S.Gowtham at all from Institute of Engineering , Coimbatore has developed a bottle filling machine of same size of bottles[10]. With the help of PLC, the researchers had build and implemented their logics for Industrial Crane Automation & Monitoring. The soft wiring advantage provided by the programmable controllers are tremendous. In fact, it is one of the most important features of PLCs. Soft Wiring makes changes in the control system easy, cheap and reliable.

The team of authors developed ladder logic in MICROLOGIX software and is verified in Allen Bradley. A ladder logic program of a typical application often results in complex software that is difficult to manage during configuration, and especially, during maintenance. The difficulty lies in a typical problem with a line real-time control software that is exacerbated by ladder logic.

We have introduced SCADA(Supervisory Control and Data Acquisition).It is an operator interface which enables the monitoring and processing commands, such as controller set points are being handled here through a SCADA computer system. The SCADA, being developed to access to a local modules which could be from any different manufacturers and allows access through the standard automation protocols.

OBJECTIVE:

The Main objective to make this project is to introduce the interface between the human working in industry and with the industries. This project once implemented can save a lot of time of an individual so that this precious time can be saved to utilize on some other work. The entire work is being done on PLC which is the brain of the project. Since it is easily programmable, it makes more sense to use the PLC. The project has two programmed parts, one for filling and the other for capping. Normally the filling and capping of the bottles(as the motive of this project) can be used in the processing and manufacturing industries to make the process simpler and easier[6]. Also in the present time, we know that with the advent of industrialisation, the more work is being done by the machines as compared to the humans. This is only because they are programmable and as once they are programmed, they can do the specific work for which they are being programmed.

The filling of the bottles can be considered as one programmable part of this project, where it will fill the bottles as the conveyer(movable by d.c, geared motor) moves the bottle being filled.[9]. The next programmable part of this project is the capping of the bottles. As when it is programmed through PLC, it will cap the bottle which was filled(as the first program of this project). In the project, as we are using the PLC. The objective to make the project using PLC is it's easy maintenance, implementation and the main purposes for which it is used is its decision making programming capability, to control the crucial tasks and adjust the process control flow adaptability. The PLC is here to eliminate the hard wiring which is the main reason for the less maintenance, and could be connected to the plant computer systems easily.

METHODOLOGY:

At first, the auto selection switch is selected so that the entire system operates automatically. Then the "Auto start push button"(toggle switch is used here) is selected and the conveyer starts moving. The D.C. motor whose shaft is coupled directly with the shaft of the roller. This motor has an input voltage of 12v with an input current of 600milliAmpere to

14Ampere. The reason for selecting torque at a constant speed. It has some definite torque. The motor now comes with a metal gearbox and centered shaft. The reason for choosing a high torque is having such heavy rollers used on the either side of the hardware which is mounted with a conveyer belt to make it movable.[8]

As this process takes place the entire system is turned OFF automatically. It remains in the OFF mode till the tank is refilled with water up to a certain level where the float switch comes to completely horizontal position. After the tank is completely filled with water the activity of the motor as well as the belt is resumed again respectively.

The EMERGENCY SWITCH has also been introduced in the system which will work like a circuit breaker and disconnects the entire PLC system whenever any unfavourable conditions arise[8]. The electrical connection of the system interfacing the hardware with the PLC machine. A ladder logic(LAD) has been implemented using the SIEMENS software or LogixPro in order for the better understanding of the system, so that when the machine is online and the program is downloaded, we can keep record of which part of the machine is online as per the requirement and can continue the process.

COMPONENTS USED

1. PLC: - A programmable logic controller (PLC) is an industrial digital computer which is used in various and they act as the brain of the devices where they are used. With PLC the revolution in industries is changing very rapidly and with its effort they are helping industries to move towards automation. They are used in industries where the filling and capping of bottle, also used in traffic controlling system. The PLC is used because they are the controller of the devices in which they are used. PLCs are used to produce the output in a specific time and so they are the examples of "Real time system". After using PLCs in various applications, it helped to replaced hard wired relays.
2. RELAY: - These are electromagnetic switches which are coiled. When a voltage is applied to a coil the magnetic field is generated and this field sucks the contact of the relay in causing them to make a connection. From here only, the concepts of NO (normally open) and NC (normally closed) has appeared in PLCs.
3. GEARED D.C. MOTOR: -12Volts 100RPM geared motors used for the robotics applications and has approximately weight of 125grams.
4. TIMERS AND COUNTERS: -These are digital blocks. Timers in PLC count the time as given by the user to execute a task while the counters counts the pulses at every time of an operation and as the count equals and the time is reached, the operation gets executed.
5. PROXIMITY SENSOR: - It is a type of photoelectric sensor which detects objects, and checks either any changes on the surface conditions. Mainly it consists of an emitter and receiver which emits and receives the light respectively.
6. CONVEYOR BELT: - It is a type of flexible belt which slides the object placed on it from one point to another point to perform the task. The belt is in a loop form and it works with the help of using geared motors.
7. BIT SHIFT REGISTER: - The shift register gives the instruction to shift the data through a predefined number of bit locations. As an example in our project when the bottle gets filled, counter and timers gives instruction to the shift register and the register is able to shift the filled and capped bottle with an unfilled and uncapped one.

BLOCK DIAGRAM:

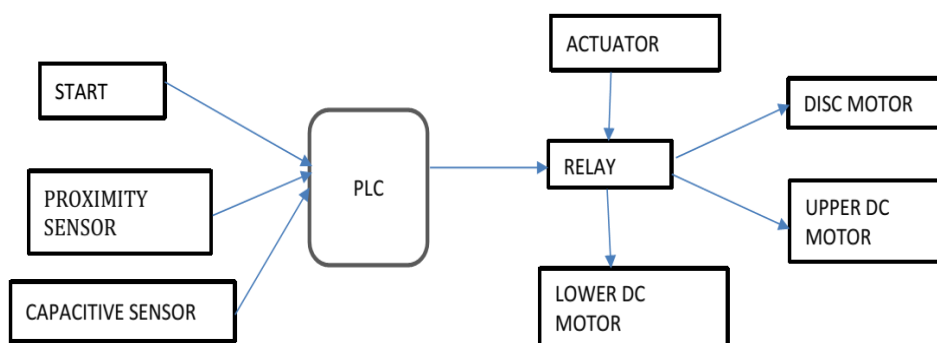

With the start of PLC button, we then start the conveyor belt with motors running. The proximity sensor then sense the presence of bottle on the conveyor belt and at the same time the capacitive sensors used as input device. The actuators will help to move the bottle on the conveyor belt. The other motors with the conveyor synchronizes to obtain the output.

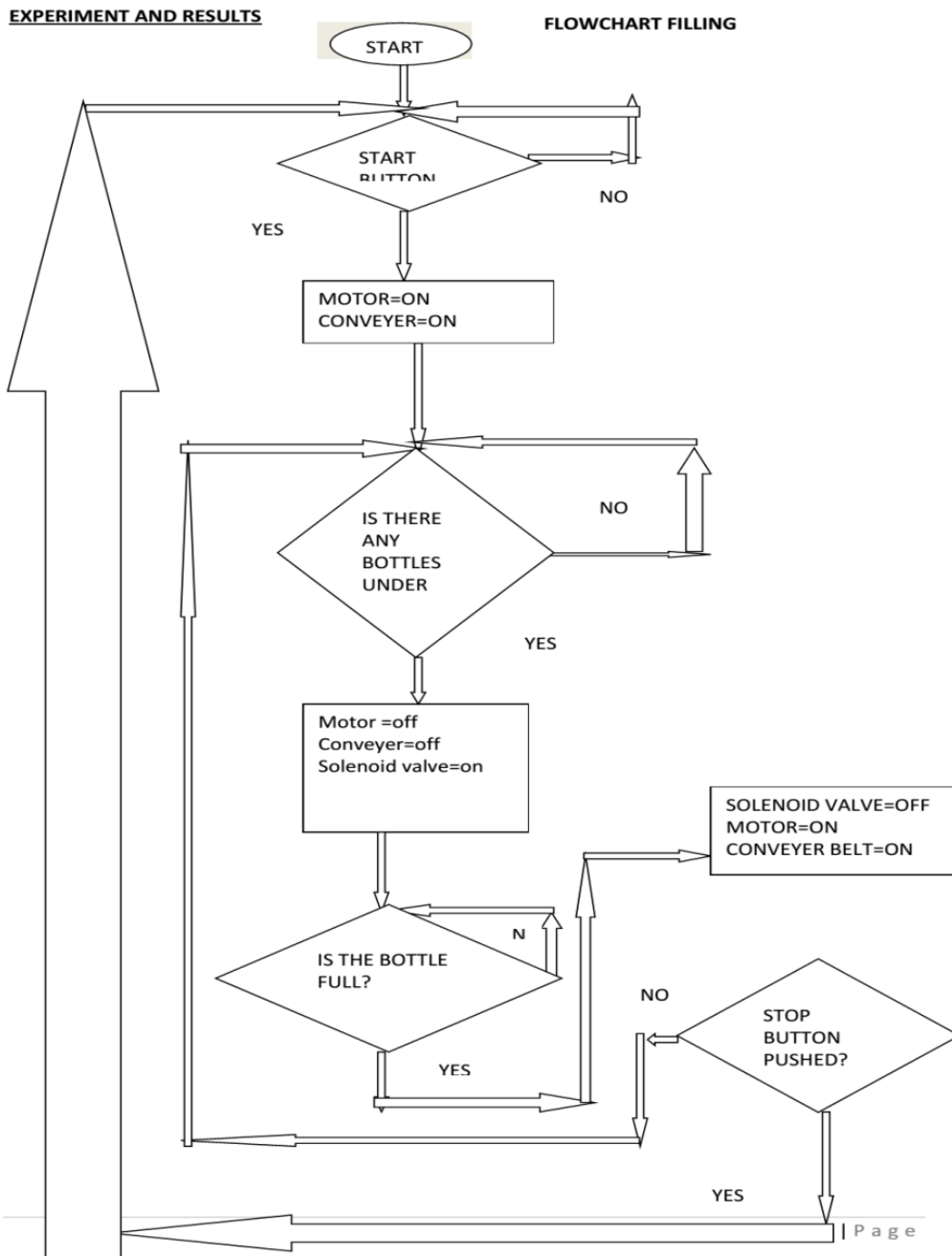

ALGORITHM

STEPS;

- 1) Start the process by pressing the start button.
- 2) The motor will get start and the conveyer belt will move ahead.
- 3) As the sensor placed to sense the bottle at the conveyer senses and detects the presence of the bottle placed on the conveyer belt which is in position of the solenoid valve, the conveyer will gets opened.

- 4) When there is no detection of bottles on conveyer, the conveyer will continue to move.
- 5) After some delay the valve will turn "ON" and the bottle will get filled till the timer gets off.
- 6) After the bottle gets filled, a delay is provide and then after the delay the motor starts running.
- 7) The process will repeat from step3.

LADDER LOGIC FOR BOTTLE FILLING

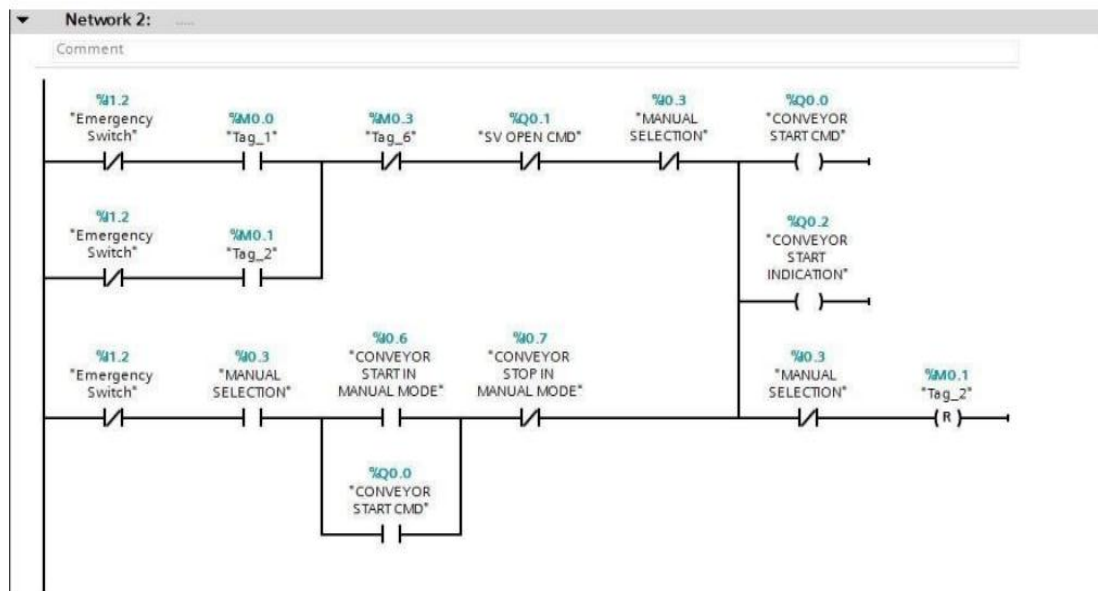
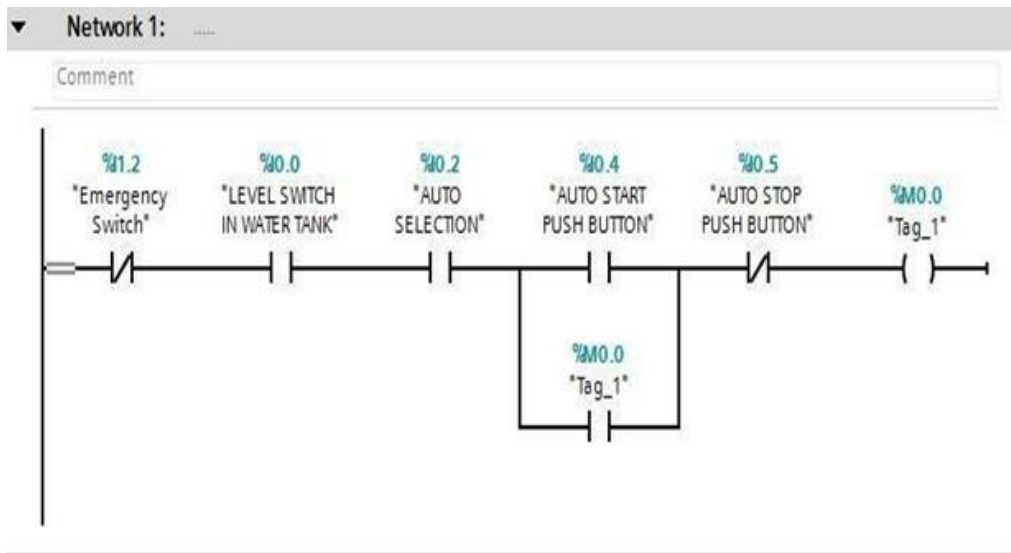

Network 3:

Comment

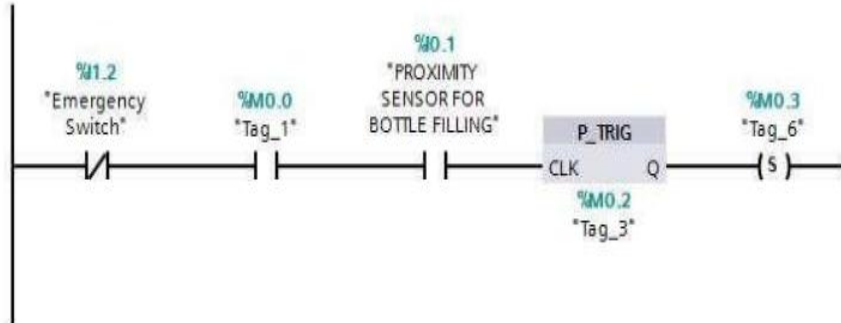

Network 4:

Comment

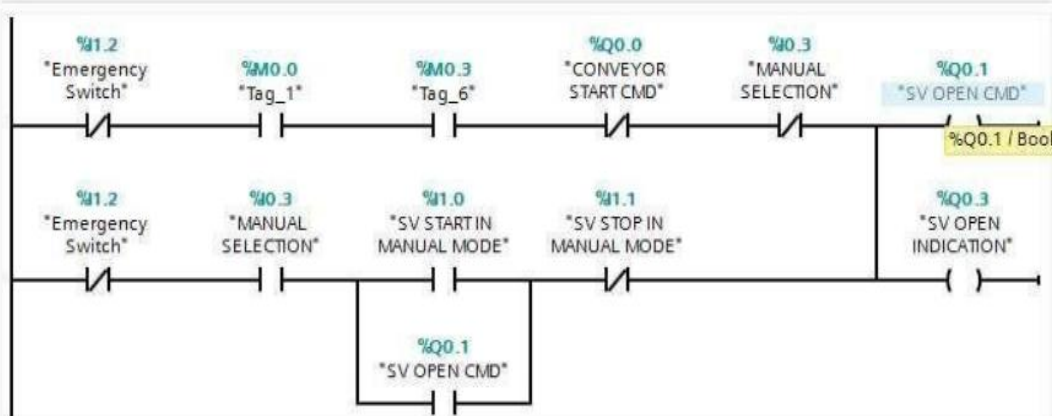

Network 5:

Comment

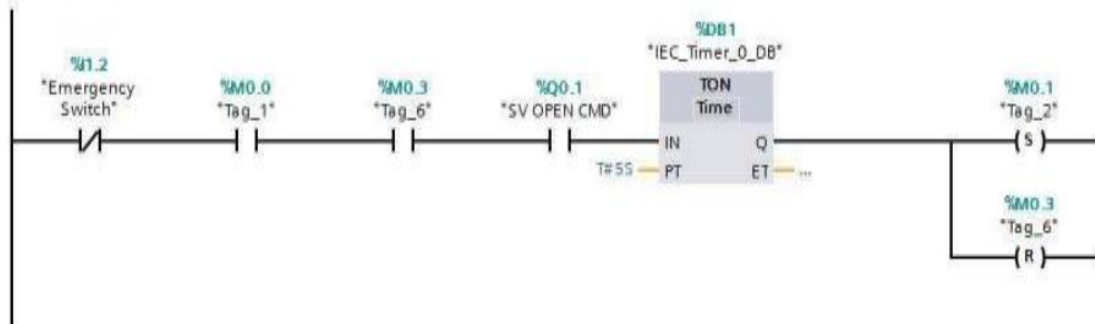

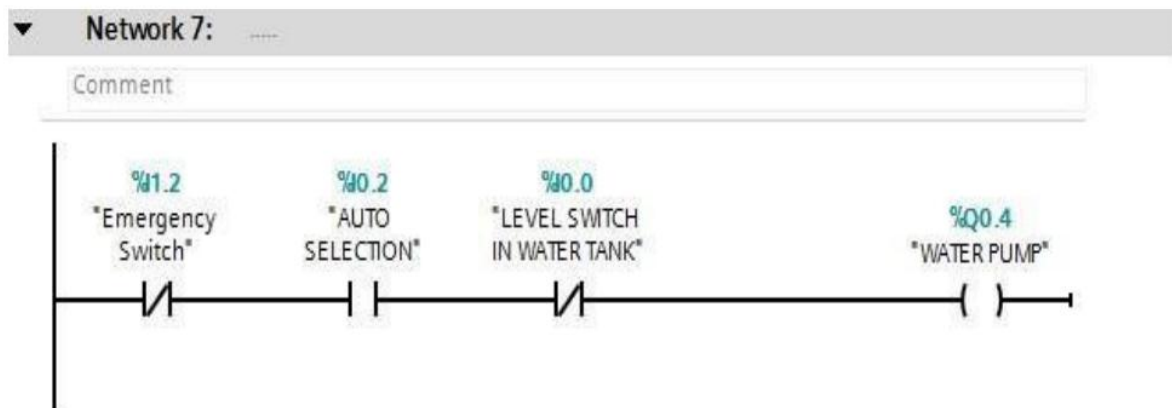
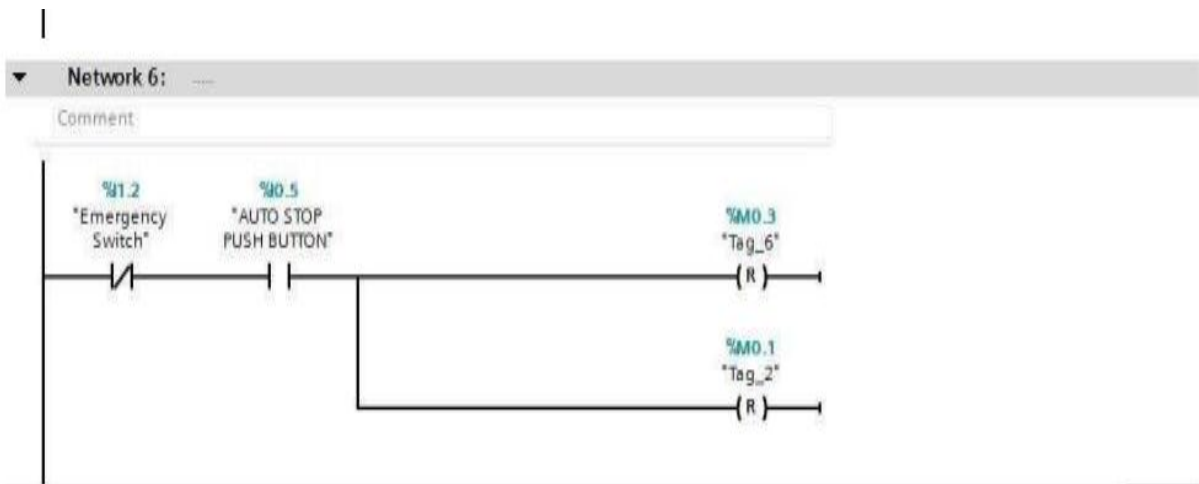

AND FOR THE CAPPING

- To sense the bottle, bottle sensor is used.
- Timer is used to stop the conveyer for 1sec for capping procedure.
- Bit shift register is also used to perform this operation. The register will count and shift the bottle serially.
- Count the number of steps capping machine is placed from the sensor and set bit position to operate machine accordingly.

LADDER LOGIC DIAGRAM FOR BOTTLE CAPPING

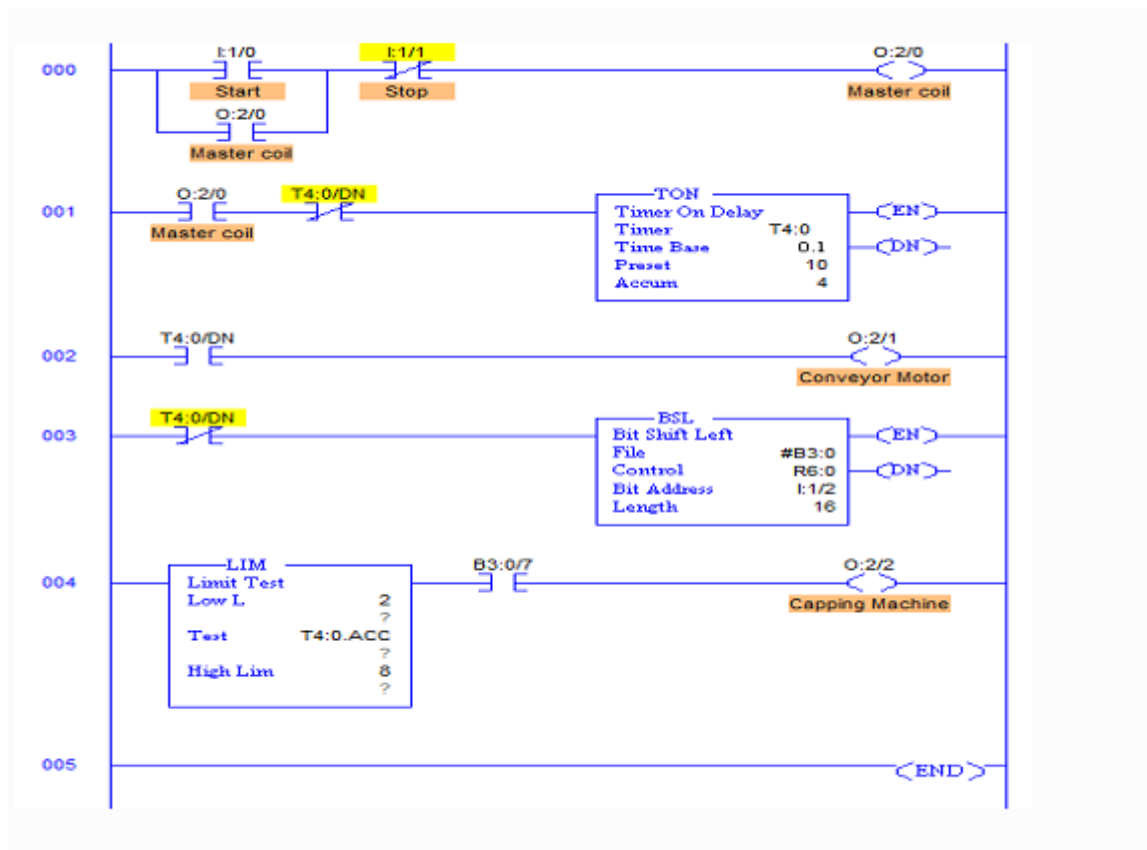

CIRCUIT DIAGRAM

In a project, we are using the PLC somatic S7-1200, which is the ideal processing part in it. They have the integrated I/O ports which are very compact and they have the space saving designs[7].The circuit diagram of the above project for the bottle filling using this PLC will look alike:-

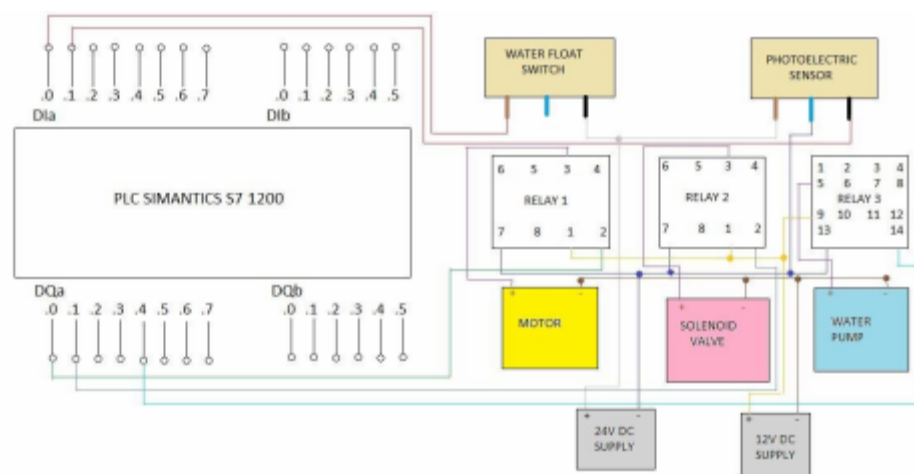
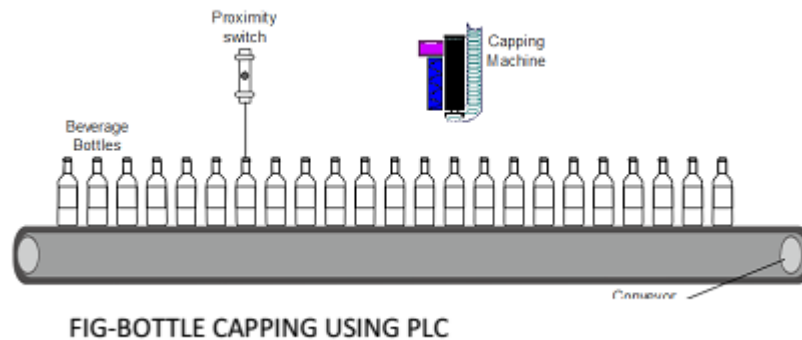

FIG- CIRCUIT DIAGRAM OF BOTTLE FILLING



RESULT AND DISCUSSION

Software Test

According to the working process of the system PLC programming, Ladder Logic(LAD) simulation software TIAV12 has been used(or could be PLCopen Editor). PLC programming in the form of Ladder Diagram has been designed to work this project.

Pump Control

Used to control the pump during the filling of the bottles placed at the conveyer belt. It works using the motor. The pump will help to fill the fluid inside the bottle.

Filling Process

As the empty bottle sent in to filling area the position sensor placed at the conveyer belt and proximity sensor confirmed the perfect position of bottle for filling. Solenoid Valve open for particular time to fill required amount of liquid in the bottle. When the bottle gets filled, then it will be sent for the next operation.

CONCLUSION AND FURTHER SCOPE FOR DEVELOPMENT

The above project made with the help of Programmable Logical And Controller was to contribute to the industry so that the demand could be accomplished. The above project will help to cap and to fill the bottle by using the new technology. The development of this project would involve the contribution to the improvement in the life of an individual. The PLC introduced in this project(which is also the brain of this project).

On installing of the jet nozzle and using the strong solenoid valve in the above program, the time to fill the bottle and to cap it get's reduced to that which takes the time to fill and cap the bottle in the above described project. Since the time decreases, the efficiency and the productivity of the project will also get increase. The labour work was reduced to the installation of the PLC.[8]

In the capping section which was introduced after the programmed filling section part, the nozzle positioning to the neck of the bottle should be taken care and with more concentration. If the system gets redesigned by increasing the hardware size and timer, the bottle size can be increased to fill more fluid inside the bottle.[8]

The project given above could be more efficiently and effectively worked when we use different other types of PLC like as MITSUBISHI, SIEMENS etc. Since their programmed algorithm is much complex, they do many complex operation(if performed in this project like shaping etc.)could be more effective. The project can also be simplified and structured if we use PLC with SCADA(Supervisory Control and Data Acquisition).

REFERENCE

- [1] PLC based Automation Bottle Filling and Capping System with user defined volume section-8th August 2012.
- [2] AUTOMATIC BOTTLE FILLING AND CAPPING PROJECT FOR FRESHMAN ENGINEERING STUDENTS-June 2005.

- [3] PLC BASED AUTOMATIC FILLING-2nd May 2015.
- [4] Dunning Gray (1998)-'Introduction to Programmable Controllers'-Delmar publishers.
- [5] Swapnil R. Kurkute"Automatic Liquid Mixing and Bottle Filling".
- [6] www.electronicstoyou.com/plc.
- [7] Industrial Automation and PLC-NPTEL/NOC COURSES.
- [8] "PLC Based Automatic Bottle Filling and Capping System With The User Defined Volume Selection" T.Kalaiselvi, R.Praveena, Assistant Professor, Easwari Engineering College, Chennai. International Journal Of Engineering Technology And Advanced Engineering(ISSN 2250-2459)2012
- [9] Petruzella Frank D(2010)-'Programmable Logic Controllers'-Tata McGraw Hill Education.
- [10] PLC BASED AUTOMATIC LIQUID FILLING SYSTEM-March 2015.