

A REVIEW ON DESIGN ANALYSIS AND OPTIMIZATION OF CENTRIFUGAL BLOWER

Prof. Kshirsagar S.R*, MaheshShinde¹, ShubhamNandgude², DipakSalunkhe³, PoojaMagar⁴

*Associate Professor, S. B. Patil College of Engineering, Indapur, Pune-413106, Maharashtra, India

^{1,2,3,4}Student of S. B. Patil College of Engineering, Indapur, Pune-413106, Maharashtra, India

Abstract- Blower is used to deliver the air or gas with an appreciable rise in pressure against the flow resistance. It is an important role in various industries for air-conditioning systems, furnaces and dust or fume extraction systems. Based on the input data the design calculations have been carried out and modelled using SOLIDWORKS. The clean-up and meshing are carried out in CFD Analysis. The Main Aim Behind these Project for increase energy efficiency & constant air flow delivery that enable them generate energy of up to 84% efficiency. Done the CFD investigation for getting improved parameter blend utilizing prepare. This will provide optimised design of centrifugal blower this paper gives the solution to above problems by optimization of centrifugal blower impeller by static and modal analysis using FEA for the material MS.

Keywords- Blower, Computational fluid dynamics, Analysis, Optimization, Blower impeller.

1. INTRODUCTION

In modern paper machine dryers, high-temperature fumes are used. In order to compensate for the cross moisture profile of the web, an experimental blow system consisting of a number of modules with micro-nozzles was used in the conducted research project. The high speed of air micro-streams acting on the paper surface improves the drying efficiency of the web, however, it requires much higher overpressure, than those used in traditional blowing systems [11].

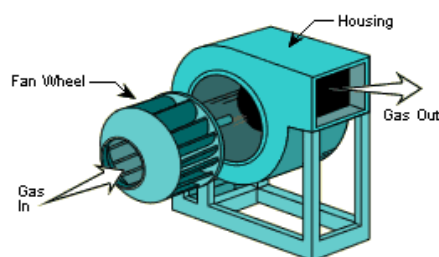

Fig [1] Parts of Centrifugal Blower [2]

Blower Are One of the type of turbo machinery which are used to move Air continuously With in slight increase in static Pressure .They increase the air speed with the help of rotating Impellers .The Modeling of the blower was done by using Solid Modeling software CATIA V5R20 . The CFD part is used for improvement the results of Static Pressure generated at the entry to the impeller, static efficiency. The

CFD optimization also helped to improve the flow pattern through the centrifugal fan system. Centrifugal turbo machines are commonly used in many air-moving devices due to their ability to achieve relatively high-pressure ratios in a compact configuration compared with axial fans. Computational fluid dynamics (CFD) packages have used to study the turbo-machine and computational fluid dynamics has an effective tool for analysis the centrifugal blower performance. The Navier-Stokes equation by the finite volume method which has been applied widely in fluid mechanics and engineering applications .A CFD-based computational tool to analyze fluid flow in a centrifugal blower. Global quantities such as pressure rise, horsepower and efficiency were compared between numerically simulated results and measured data [12].

2. LITERATURE REVIEW

The performance of the fan obtained by different fan laws. Hence lot of emphasis is given to understand the basic theory of fans, their types and their working. The selection of critical parameters is very essential and determining the performance of the fans [14]. The basic equations mainly continuity equation, momentum equations and energy equations need to be considered while following the computational fluid dynamics approach. While considering any practical problem the best turbulence model and order of accuracy needs to be selected for good results [15]. When carrying out the design optimization of centrifugal fans, centrifugal blower where the mass flow variation is controlled by mobile ante rotor and not by speed variation of the electrical motor [16]. For vibration analysis of blower need to know the parameters which cause vibration and also the method to measure vibration with proper setup arrangements [17]. Due to vibration the life of bearing of blower is reduced. The life of bearing can be improved by carrying corrective actions on blower & modifying its accessories like Plumber block to prevent bearing failure [18].

3. AERODYNAMIC PERFORMANCE

The aerodynamic performances curves of the fan are illustrated in the experimental data given in are the averaged values for the results of three experimental tests, where the standard deviation is also plotted as error bars. As described in Section the internal leakage loss was not taken into account in the numerical simulation because the radial gap between the inlet nozzle and the impeller inlet was ignored.

The above simplification was an important reason that the TPR obtained from the flow simulation was higher than the experimental data tested at the same VFR. Note that the experimental efficiency curve includes both mechanical and electrical losses that are not considered in the numerical model, while the numerical efficiency curve approximates better the experimental values than the numerical total pressure one because the an approximate value 0.8 of the motor efficiency was employed to modify the numerical efficiency curve. Although the above-mentioned deviation between the numerical result and the experimental data exists, both of them indicate that there is a slight decline of TPR and efficiency for the centrifugal fan equipped with the OCMF [13].

4. DESIGN OF CENTRIFUGAL BLOWER.

4.1 Phase I – Blower types

The centrifugal fan uses the centrifugal power generated from the rotation of impellers to increase the pressure of air/gases. It may be classified into three basic types according to blade configuration: forward curve, backward inclined, and radial or straight blades [1]. Because of its high static pressure and capability of handling airstreams containing a high level of particulate, radial blade is suitable for the application of dust laden. The open wheel or paddle wheel is the most common of the radial blade impellers. Air wheel and radial tip impeller are the other variants of radial impellers ideal for contaminated airstreams but neither is intended for bulk material handling [2].

4.2 Phase II – Parametric study on blowers

The critical parameters of the centrifugal fan impeller is found out which highly affect the performance characteristics are impeller outlet width, impeller outlet diameter, blade thickness, impeller blade outlet angle, and number of blades [3]. Comparisons are conducted between the fan with original impeller and two larger impellers with the increments in impeller outlet diameter of 5% and 10% respectively in the numerical and experimental investigations. Experiment results show that the flow rate, total pressure rise, shaft power and sound pressure level have increased, while the efficiency have decreased when the fan operates with larger impeller [4]. The tip clearance (i.e. distance of the blade with top of the casing) has been deduced that the impeller with backward-curved blades was very sensitive, whereas the other two types were not. The impeller with radial tipped blades showed a weak dependency on tip clearance. However, for the case of fully radial blades, it has been observed that the fan is almost insensitive to the tip clearance [5]. The inlet radius has major impact on the flow rate of the centrifugal blower. Too small or too large of a radius will result in a noticeable loss in the flow rate. Too small of a radius will have negative impact on flow rate. Anyway, it's best to have the bell mouth radius ratio at the value around 9% [6].

4.3Phase III – CFD Analysis

Computational Fluid Dynamics usually abbreviated as CFD, is a branch of fluid mechanics uses numerical methods and algorithms to solve and analyze problems that involve fluid flow [3]. The CFD part is used for improving the results of static pressure generated at the entry to the impeller, static efficiency. The MRF (moving reference frame) applied in the CFD analysis of centrifugal fan as a rotating region around the impeller and component of the impeller stationary [7]. A 250mm backward curved blower impeller in a shroud was tested and modeled in two CFD scenarios: one which resolves the impeller and shroud geometry and one which requires knowledge of the pressure versus flow curve and models only the shroud geometry. Comparing with the test data MRF models predict the flow fields much better than the lumped compact models using the P-Q curves [8].

4.4Phase IV – Design of Experiments

Design of experiments (DOE) or experimental design is the design of any information-gathering exercises where variation is present, whether under the full control of the experimenter or not[3]. The experimental results are justified by Analysis of Variance (ANOVA) [9]. The blower housing was optimized using a Design of Experiments (DOE) technique where the geometry of housing was varied in a structured manner to capture expected sound order behaviour [10].

5. ANALYSIS OF CENTRIFUGAL BLOWER.

The 3D modeling of the blowers are created using

SOLIDWORKS. The major parts of the blowers are fan inner diameter, fan outer diameter, blade inlet width, blade outlet width, number of blades, blade thickness, and volute casing.

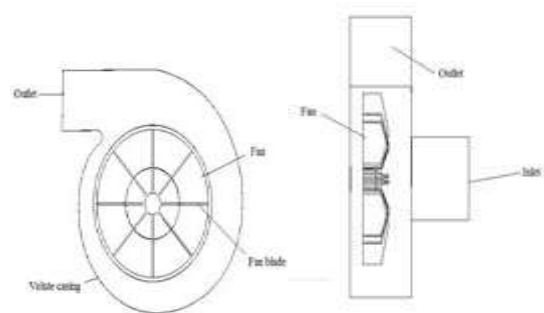

Fig [2].Front & Side View Of Centrifugal Blower [1].

The geometry of the blade depends on fan diameters and blade angle. For each number of experiments, the blade profile varies which could be constructed using tangent circular arc method.

$$\rho = (R2b - R2a) / 2(Rb \cos \beta b - Ra \cos \beta a)$$

$$Rb = \text{Fan outer radius, } Ra = \text{Fan inner radius, } \beta b \& \beta a.$$

The air flow inside a blower is high turbulent flow. Therefore, this study simulates the complex flow patterns inside the centrifugal blower by using the commercial computational fluid dynamics software Fluent to solve the fully three-dimensional incompressible Navier–Stokes equations by the standard $k-\varepsilon$ turbulence model. The steady $k-\varepsilon$ simulation is performed with the moving reference frame (MRF) model to deal with the rotating fluid inside a centrifugal blower. The projected total pressures with the various airflow rates on operating points can be used to determine the performance curve. Based on the calculated torque it is then possible to calculate the blower efficiency for the entire performance curve[11].

6. CFD ANALYSIS.

Computational Fluid Dynamics (CFD) approach is the effective method of solving non-linear partial differential equations that governs fluid flow, heat transfer and turbulence of flow. In this present study, CFD FLUENT is used to solve the flow inside the centrifugal blowers. Moving Reference Frame (MRF) method is adaptable for the condition where fluid rotates. A separate cell zone has to be mentioned for MRF method, the second cell zone condition in our study was considered as MRF zone. The assumptions made for this study are,

- i. Steady state air flow
- ii. Implicit solver
- iii. Standard wall function
- iv. Second order upwind scheme [11].

7. CONCLUSION

Experimental and numerical studies were carried out to investigate the effect of the OCMF on the aerodynamic performance and noise of a centrifugal fan in order to develop a passive method for controlling centrifugal fan noise. As a first step of the research project, the present design of the OCMF is preliminary as no optimization is carried out. In this study, the performance and flow characteristics inside a centrifugal fan used in commercial boilers are numerically studied and the elicited results are compared with experimental data. The main focus of the study was maintained on the flow characteristic of the fan ribs inside a centrifugal fan blower, based on fan performance assessment for various shapes of its internal components.

REFERENCES:

1. Twin city fan companies, 2000, "Fan Engineering – Fan performance characteristics of centrifugal fans", FE-2400.
2. Bureau of Energy Efficiency, "Fans and Blowers", 96.
3. Vijay pratap R Singh, Zinzuvadiah M J, Saurin M. Sheth, 2014, "Parametric Study and Design Optimization of

- Centrifugal Pump Impeller-A Review", *Int. Journal of Engineering Research and Applications*, 2248-9622, Vol. 4, Issue 1(Version 1), 216-220.
4. Li Chunxi, Wang Song Ling, and Jia Yakui, 2011, "The performance of a centrifugal fan with enlarged impeller", *Energy Conversion and Management* 52, 2902–2910.
5. Xianan Romani´Ferna´ndez and Hermann Nirschl, 2013, "Simulation of particles and sediment behaviour in centrifugal field by coupling CFD and DEM", *Chemical Engineering Science* 94, 7-19.
6. Pham Ngoc Son, Jae Won Kim, Byun S. M., Ahn E. Y., 2012, "Effects of inlet radius and bell mouth radius on flow rate and sound quality of centrifugal blower", *Journal of Mechanical Science and Technology* 26 (5) 1531~1538.
7. Keyur K., Patel, Prajesh M. Patel, 2013, "Performance Improvement of Centrifugal fan by using CFD", *IJSET - International Journal of Innovative Science, Engineering & Technology*, Vol. 2 Issue 4, April 2015. www.ijset.com ISSN 2348 – 7968 84 International Journal of Advanced Engineering Research and Studies, Vol. II/ Issue II 2249–8974.
8. Xiaojin Wei, Levi Campbell, Ethan Cruz, Peter Kelly, 2014, "Modeling Blower Flow Characteristics and Comparing to Measurements", *IEEE - 978-1-4799-4374-6/14*.
9. Ragooth Singh R, 2012, "Optimizing impeller geometry for performance enhancement of a Centrifugal blower using the Taguchi quality concept", *International Journal of Engineering Science and Technology*, Vol. 4 No.10 0975- 5462.
10. Garron K. Morris and Bruce W. Weiss, 2012, "Driving Energy Efficiency with Design Optimization of a Centrifugal Fan Housing System for Variable Frequency Drives", *IEEE ITherm Conference* 978-1-4244-9532-0/12
11. Jayapragasan.C.N1, Manojkumar.A2, Dr. Janardhan Reddy.K3: Design Optimization and Parametric Study on the Alternative Blower of Travelling Cleaner: ISSN 2348 – 7968.
12. 1Kesare Sunil Vikas, 2Prof. Swami M. C: Analysis and optimization of Centrifugal Blower by using FEA: 2016.
13. Chen Xu, Yijun Mao: Passive control of centrifugal fan noise by employing open-cell metal foam: 2016.
14. Yahya S M. 1998. Turbines Compressors and Fans. Tata Mc-Graw Hill Edition.
15. Anderson J.D. 2012. Computational fluid dynamics. Tata Mc-Grew Hill Edition.
16. Bogdam Gherman, Cristina Silivestru and Marian Draghici, Aerodynamic geometry optimization of a centrifugal blower.
17. Asad Said Jama Al Zadjali and G.R Rameshkumar, Condition monitoring of centrifugal blower using vibration analysis.
18. B.A Kardile, Bearing life improvement of centrifugal blowers by vibration analysis.