

# Low Cost Compact – Multipurpose Agricultural Tool for the International Research Journal of Engineering and Technology

Nachiketh R<sup>1</sup>, Shriram Vijaykumar<sup>2</sup>, Adarsh V Ramanan<sup>3</sup> and Anjan N<sup>4</sup>

<sup>1,2</sup>Industrial Engineering and Management Department, BMS College of Engineering, Bangalore, Karnataka, India

<sup>3,4</sup>Mechanical Engineering Department, Global Academy of Technology, Bangalore, Karnataka, India

\*\*\*

**Abstract;-** The main objective of this project is to fabricate a harrowing machine of low cost that consumes less time, man power and thereby increase productivity. We are aiming to make a simple, compact machine that is easy to maintain and a machine that does not interfere with the plants while being used and reduces dependency on man power.

Scope of the project includes following

- a) To study conventional harrowing and identify its drawbacks.
- b) To design, fabricate a simple and compact harrowing machine that overcomes the difficulties of conventional harrowing.
- c) Analysis of the compact machine which proves its strengths during action.

## 1. Introduction

Black gram popularly known as “Urad” is one of the most important pulses crop grown across India. The urad crop is resistant to adverse climatic conditions and improves the soil fertility by fixing atmospheric nitrogen in the soil. The upper layer of the soil needs to be loose enough to hold the atmospheric nitrogen. The seeds are sown at the depth of 2cm and with a spacing of 1metre between the rows. Urad dal/Black gram is cultivated during both summer and rainy season and requires well drained soil that can retain moisture. Hence, the land requires 2-3 times of harrowing prior to monsoon.

Harrowing plays an important role in both the seasons to aerate the soil for nitrogen fixation and to improve the water holding capacity.

Harrow is an implement used for breaking up and smoothing out the surface of the soil, mainly required for the cultivation of cereals. Harrows are used to uproot weeds, aerate the soil and cover seeds. Conventionally, a harrow consists of a wooden or metal framework, bearing metal in the shape of sharp projecting points called tines or discs. These tines are dragged over ploughed land to pulverize the clods of earth and level the soil. Even today in most parts of the country bullock carts drag harrowing tool which consumes energy, money and time.

Reasons for Harrowing:

- ☑ Root aeration, for better water infiltration and growth.
- ☑ Helps to remove lightly rooted weeds.
- ☑ Removal of dead grass from the base of healthy grass.
- ☑ Posture renovation breaking up and leveling heavy soil.

## 2. Scope

Scope of the project includes following

- a) To study conventional harrowing and identify its drawbacks.
- b) To design, fabricate a simple and compact harrowing machine that overcomes the difficulties of conventional harrowing.
- c) Analysis of the compact machine which proves its strengths during action.

## 2.1 Problem Statement

- ❑ Conventionally, in our country harrowing with bullocks consumes lot of time and money, especially in the cultivation of pulses, as it involves 2-3 times of harrowing.
- ❑ The labor cost is rs.400 per head/day. An acre of harrowing requires minimum of three-man power and a pair of bullock.
- ❑ Presently the cost of a pair of bullocks is approximately Rs 50,000/-.
- ❑ Considering a mid-level farmer with 10 acres of land, the total cost incurred for a minimum of 10 acres is-

$$[(3 \times 400) \times 10] + 50,000 = \text{Rs } 62,000/-]$$

- ❑ The farmer has to spend even more on the maintenance of these bullocks which brings the total cost above Rs1 lakh!
- ❑ The harrowing machine costs not more than Rs.20,000/-
- ❑ Thus, by designing and fabricating this machine we can reduce time, money and manpower.
- ❑ Also, dependency on manpower which is unavailable at right time is eliminated.

## 2.2 Methodology

In agriculture, a harrow is an implement for breaking up and smoothing out the surface of the soil. In this way, it is distinct in its effect from the plough, which is used for deeper tillage. Harrowing is often carried out on fields to follow the rough finish left by ploughing operations. The purpose of harrowing is generally to break up clods (lumps of soil) and to provide a finer finish, a good tilth or soil structure that is suitable for seedbed use.

A harrowing machine is an agriculture equipment, powered by an IC engine. This machine consists of a harrowing tool that is dragged in between the crop rows of the field to break up lumps of soil and to provide a finer finish for seedbed use.

Parts of Harrowing Machine:

1. **Frame**- the frame supports and forms the base for the entire equipment. It holds various parts of the equipment such as engine, shaft, tool, wheel etc.
2. **Engine**-An engine is a machine designed to convert heat energy into energy. Heat burn a fuel to create heat, which is then used to drive shafts and hence the wheel. The engine we are using in this project is active 110cc engine.
3. **Petrol tank** - petrol tank is a safe container for flammable fluids. Though any storage tank for fuel may be so called, the term is typically applied to part of an engine system in which the fuel is stored and released into an engine.
4. **Shaft**-A shaft is a rotating machine element, usually circular in cross section, which is used to transmit power from one part to another, or from a machine which produces power to a machine which absorbs power. The material used for the shaft is mild steel.
5. **Roller chain**-Roller chain or bush roller chain is the type of chain drive most commonly used for transmission of mechanical power on many kinds of domestic, industrial and agricultural machinery. It consists of a series of short cylindrical rollers held together by side links. It is driven by a toothed wheel called a sprocket. It is a simple, reliable, and efficient means of power transmission.
6. **Sprocket**-A sprocket or sprocket-wheel is a profiled wheel with teeth, cogs, or even sprockets that mesh with a chain, track or other perforated or indented material. It is distinguished from a gear in that sprockets are never meshed together directly, and differs from a pulley in that sprockets have teeth and pulleys are smooth.
7. **Harrow**- A harrow consists of a metal framework, bearing metal in the shape of flat rectangular plate having a sharp edge that is dragged over ploughed land to pulverize the clods of earth and level the soil.

**2.3 Working Principle of Harrowing Machine:**

A harrowing machine consists of an engine that drives the entire machine throughout the field. The engine that is used to drive the equipment is a 4-stroke petrol engine. An activa engine with a fuel capacity of 110cc is used to drive the equipment. The engine converts the chemical energy of the fuel into mechanical energy.

The fuel tank supplies the fuel required to drive the engine and hence the machine. The capacity of the fuel tank is 3 litres.

The engine is kick started to initiate the driving of equipment. A crank lever is used to start the engine. The engine can also be started by a battery of 12 volts.

The machine consists of a harrowing tool that can be dragged over the entire field for breaking up the clods of soil. There are two types of harrowing tool, a longer tool of length 770mm and a shorter tool of length 235mm. The choice of tool depends on the space between the two row of crops. A 770mm tool is preferred for larger gap, while a 235mm tool is preferred for smaller gap between the rows supports the tool. The tool can be raised or lowered with Engine type 4 stroke, SI engine the help of adjustable screws provided in the tool holder, so that the tool doesn't go too deep into the soil. The screws Cylinder capacity 109cc Starting method Kick/self -start provided in the tool holder, when rotated clockwise lifts the tool up and when rotated anticlockwise lower the tool.

The equipment is provided with a seat so that the user Bore Stroke 50 mm 55.6 mm can sit on it and drive the equipment easily. The equipment Compression ratio 9.5:1 consists of a handle, similar to that of a power tiller for controlling the direction of the equipment. The user can Max net power 5.86 kw (8bhp) @7500 rpm drive the machine throughout the field and the harrow performs its functions.

Max net torque 9nm@5500 rpm Fuel consumption 30-35 km/l can be used for stopping the equipment whenever required Air filter type Viscous paper filter by applying brakes. The equipment is driven in such a way that the wheels move in the space between two rows of crop. The frame is designed in such a way that it does not affect the plant as the equipment moves over it.

The engine provides the necessary energy to drive the tool easily in the field without any extra effort. A single person is enough to handle the equipment.

The most important feature of the machine is that we can remove the harrowing tool and put any other tool like water or pesticide sprayers, weed remover or any other tool which can be used for agricultural purposes.

**2.4 Technical Specifications:**

**Table 1 Engine Specifications**

BODY DIMENSIONS	
Length	2000mm
Width	600mm
Height	1050mm
Front wheel	600mm
Handle	300mm
Ground clearance	300mm
Seat height	500mm
Kerb weight	80kg approx.
Fuel tank capacity	2.5 litre

**Table 1 Body Dimensions**

TRANSMISSION	
Type	Chain drive

**Table 1 Transmission Type**

ENGINE SPECIFICATIONS	
Engine	4 stroke, SI engine
Cylinder capacity	109cc
Starting method	Kick/self-star
Bor	50 mm
Strok	55.6 mm
Compression ratio	9.5:1
Max net power	5.86 kw (8bhp) @7500 rpm
Max net torque	9 nm @5500 rpm
Fuel consumption	30-35 km/l
Air filter	Viscous paper filter
Cooling type	fan cooled

**Table 1 Engine Specifications**

TYRES & BRAKES	
Tyre size (left)	680mm diameter
Tyre size (right)	680mm diameter
Rim size (left)	570mm diameter
Rim size (right)	570mm diameter
Brake type & size	130mm diameter (Drum brake)

**Table 2 Tyres and Brakes**

Material	Mild steel
Length	1150 mm
Width	130 mm
Thickness	5 mm

**Table 1 Tool Holder Specifications**

TOOL SPECIFICATIONS	TOOL 1	TOOL 2
Material	Mild steel	Mild steel
Length	235 mm	770 mm
Width	60 mm	100 mm
Thickness	7 mm	9 mm

**Table 2 Tool specification**

### 3. Methodology

#### DEFINING THE PROBLEM STATEMENT

The problem here was to overcome the use of bullocks for conventional harrowing by designing equipment that reduces the cost of labor. The main aim here was to develop an alternative with the help of easily available resources. The solution also includes optimization of costs incurred in manufacturing of the equipment. The first step after defining the problem is designing the equipment.

#### DESIGN OF THE EQUIPMENT

To design a frame that can hold the engine and compact enough to withstand the reaction forces. Initially a square frame was conceptualized, however the idea was dropped, as it couldn't provide enough space for full swing of kick lever while cranking.

As per the final design, a frame which is a combination of delta and ladder frame was finalized as it was strong enough to hold the structure and compact in design.

The frame length and width was designed keeping in mind the space between the two rows of plants.

A engine of higher capacity produces low torque and is less efficient at low speeds. The speeds involved in harrowing are too low (about 20 KMPH). Hence, active engine of 110cc was used, to accommodate for higher torques and better fuel efficiency.

#### PROCUREMENT OF RAW MATERIALS AND OTHER PARTS REQUIRED FOR THE EQUIPMENT

The equipment requires:

- ☐ L angle for fabricating a frame and the support for the engine.
- ☐ An engine of 110cc (Activa engine) which is in running condition.
- ☐ A shaft made of mild steel material and of 700mm length.
- ☐ Pair of Plummer blocks bearing to hold the shaft and a pair of bushes to attach the wheel to the shaft.
- ☐ Chain drives system to transmit the power from engine to the shaft.
- ☐ A bike front wheel fork required to give steering mechanism to front wheel.
- ☐ A fuel tank to store and supply the fuel to the engine'
- ☐ A metal pipe of some length to make a handle for steering of the machine and its design depends on the placement of seat.
- ☐ Brakes and accelerator cables are required to control the machine for stopping and accelerating the engine.
- ☐ An assembly of tool holder, clamp and the tool that can be dragged throughout the field by the machine.

☐ A battery of 12v for self-start.

#### FABRICATION OF FRAME

The L angle of mild steel is cut into appropriate length as required for the frame. The cutting was carried out with the help of a cut off machine. The L angles are cut in pairs as we need to build the frame.

The L angles cut were welded by electric arc welding process. But before that the outline of the frame was traced on to a hard board for easy and accurate welding. After tracing, the cut L angle pieces were placed on the outline and the welding is done at the frame joints.

After welding, the frame is allowed to cool for some time and finishing operation is done with the help of a surface grinder in the place of joints, to give it a surface finish.

For fixation of Plummer block, the frame portion is identified and holes are drilled for fixing the same.

The position at which the engine is mounted is identified and appropriate supports are provided on the frame by cutting and welding L angles of length suitable enough to hold the engine.

#### FABRICATION OF SHAFT

A circular mild steel bar of length 750mm and diameter 35mm is procured. The diameter of the circular bar is reduced to 27mm by plane turning operation, so that the shaft can be inserted into the Plummer block. The length of the shaft is reduced according to the width between the two Plummer blocks, by cutting excess length with the help of grinding cutter.

The shaft is then inserted into the Plummer block and tightened.

#### INSERTION OF DRIVEN SPROCKET INTO THE SHAFT

A metal disc for attaching the sprocket to the shaft is fabricated from a circular billet by turning operation. The metal disc is then provided with a center hole of diameter equal to shaft's external diameter by drilling operation. Four holes at right angles to each other are drilled around the center hole of the metal disc. The metal disc is welded with the shaft and bolted to the sprocket.

#### INSERTION OF FRONT WHEEL TO THE FORK

The front portion of the frame is rested on a support and the level of the frame is balanced. A metal plate of 150mm\*100mm is welded on the front portion of the frame. A support is welded on the plate according to the position of the front fork to be fixed. The front fork is then attached to the support by welding and the front wheel is attached to the fork ends through bearings.

#### PLACEMENT OF ENGINE

The Activa engine is bolted to the prepositioned supports provided on the frame. Engine supports are provided on the frame for easy maintenance. The driver sprocket is mounted on the engine output shaft in alignment with the driven sprocket.

#### PLACING OF ROLLER CHAIN ON SPROCKETS

The roller chain is placed on both sprocket and the engine is cranked to check at what position of driven sprocket, the equipment moves. At the appropriate position of the sprocket, the equipment moves and the driven sprocket along with the metal disc is welded to the shaft at that position.

#### FIXATION OF HANDLE TO THE FRONT FORK

A steel pipe is passed through the holes above the fork and the angle at which the steel pipe is to be bent is determined so that it can reach the user on the rear seat. Steel pipe bent to the required length & shape at certain angles and clamped to front fork. Supports are provided on the handle for retaining its shape after repeated usage. The right-side handle is provided

with accelerator and brake lever for controlling the front wheel. The left side handle is provided with a brake lever for controlling the rear wheels.

#### PLACEMENT OF FUEL TANK

A fuel tank of 3ltr capacity is mounted adjacent to the engine for the easy flow of fuel into the engine. The fuel tank is connected to the engine carburetor through the fuel tube. The fuel flow from the tank into the carburetor can be regulated with the help of valves.

#### ATTACHEMENT OF THE TOOL HOLDER TO FRAME

Metal plate is provided with the slots for fixing tool clamp. Square hollow rod is drilled for inserting adjustable screws. Metal plate is drilled at same position as that of rod. The rod is welded on the top of frame. Then metal plate is clamped to square hollow rod by adjustable screws. Plate can be moved up &down. The depth of the plate depends on the length of adjustable screw.

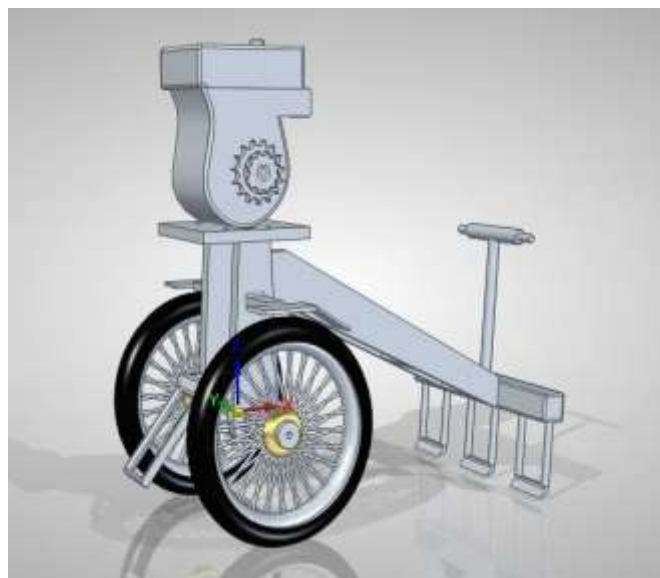
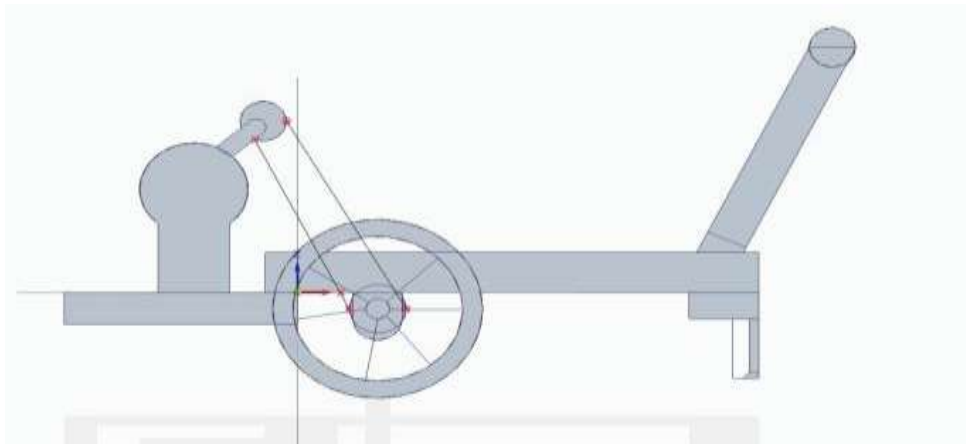



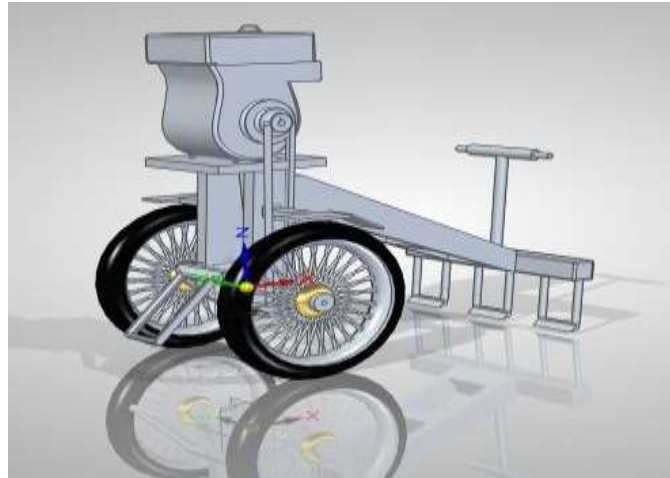

Analysis of Harrowing Machine Frame

#### LADDER FRAME:

This is a common type of frame, in which all the transverse (lateral) connecting members are straight across in the plan view. In this type, the frame resembles a ladder as the name implies.

#### PERIMETER FRAME:

A perimeter frame consists of welded or riveted or bolted frame members around the entire perimeter of the body. In this, the frame members are provided underneath the sides, as well as for the suspension and related components.

#### SUB-TYPE FRAME:

A sub-type frame is a partial frame often used on unit-body vehicles to support the power train and suspension components. Normally the various components are bolted directly to the main frame. But many a times, these components are mounted on a separate frame called sub-frame. This sub-frame is further supported by the main frame at three points. In this way, the components are isolated from the effects of twisting and flexing of the main frame.

The advantages of sub frames are:

- The mass of the sub-frame alone helps to damp vibrations

- The provision of sub-frames simplifies production on the assembly line and facilitates subsequent overhaul or repair

#### UNIT BODY CONSTRUCTION:

Unit body construction is a design that combines the body and the structure of the frame. In this, the body itself supports the engine and driveline components. In this type of construction, heavy side members used in conventional construction are eliminated and the floor is strengthened by cross members and the body, all welded together. In some cases, the sub-frames are also used along with this type of construction.

#### SPACE FRAME CONSTRUCTION:

Space frame construction consists of formed sheet used to construct a framework for the entire vehicle. This vehicle is also drivable without a body.



## CONVENTIONAL CHASSIS FRAME

Steel pressing of channel or box section form the side (frame) members. They are connected together by means of cross members (made of channel or box sections) so as to form a rigid but light frame work. The cross members are also used to mount the chassis components on them. These transverse members are usually riveted or welded to the side members, with the help of special enlarged flanges known as gusset plates.

At the front and rear ends, the longitudinal members are tapered in depth (beams of the uniform strength for minimum weight). The side rails at the front end are brought closer together when viewed in plan in order to provide space for the free turning of the steered wheels. It is usual to arch (upswept) the side rails towards the front and rear ends, in order to provide sufficient space for the vertical movement of the axles during its springing action while travelling on a rough road.

Near the front and rear ends, special brackets in the form of metal forgings are welded to form the bearing location for the spring shackles. At the rear end of the frame, it is usual to provide one or more cross strut members of channel or tubular section in order to take the rear spring forces tending to distort the frame and to provide an increased amount of torsional rigidity.

To provide a larger stability to the vehicle, the height of the body work and hence the center of gravity should be kept as low as possible. Hence the frame is kept lowered as much as possible between the front and rear axles. In the case of heavy vehicles, full length box section side rails and cross members made from medium carbon to low carbon alloy steel pressings are welded together to get chassis frame with higher strength and stiffness.

It has a diagonally braced central portion also, to carry the universal joint bearing block. The front end of the side members has flattened ends and are designed to take bumper brackets. The engine is mounted at the front, on rubber block mountings. Since the heavy-duty vehicle frames have straight side rails and cross members, similar to ladder geometry-wise, this type of frame is known as ladder type frame.

## FRAMELESS CHASSIS (INTEGRAL CHASSIS FRAME AND BODY)

Developments in the art of welding and pressing of large steels sheets into complex shapes, have allowed the integration of the frame structure and the body work as a single unit, so as to achieve a very light but a stiff structure for a given material content. This chassis cum body construction is also called as 'frameless chassis'.

The body structure is also made to take part in load sharing instead of just acting as an enclosure. This has resulted in the reduction of the heaviness required by the side and cross members considerably allowing the usage of lighter side members.

Combining the sides and cross members with the floor panel and body structure, constitutes a useful load bearing structural component which also results in considerable weight reduction.

Basically, the structure includes integration of an under frame consisting of floor panel and the cross members, the bonnet wings(sides), steel facial at front to receive the engine, rear luggage compartment or tray and other structural members behind the rear seat portion. They are all welded together as one single assembly.

The floor surfaces are ribbed and dished for additional strength and rigidity. The pressed steel body shell is attached to the chassis frame by welding. In order to carry the engine and the front suspension, a sub frame is also attached to the front of the body shell.

To mount the engine, suspension members and bumpers, the structure is further extended at the front and reinforced at the rear. A very low carbon steel (less than

0.1% carbon) having extremely good ductility is used for pressing of the panels which allows easy forming.

Since the structural panel members are made of low strength materials, they are stiffened by sections formed out of thin steel sheets into intricate sections by spot welding.

To avoid reduction of strength of the given chassis due to rusting, some special treatment against corrosion is given. For this purpose, the entire body is preferably immersed in rust inhibiting bath or protective solution to seal all joints.

This is further enhanced by coating both the inner and outer surfaces with anti-corrosive primer paint. A sound damping material is stuck on the inside of the panel to avoid panel vibration which causes an objectionable drumming sound.

#### TUBULAR CHASSIS:

The flat frame is by no means the best form to resist torsion and for this reason certain firms adopted a tubular chassis. Hence, in the flat frame type of chassis the principal members, namely the engine and transmission parts are stressed heavily by road shocks and reaction torques.

In tubular chassis, the complete transmission line which includes gearbox and differential units, are accurately aligned in a central tubular member, forked at the front end to take the engine assembly. (e.g.: tractor frame). The front axle is also carefully positioned and connected to the fork end of the frame.

Farm tractors are **usually made of tubular chassis frame of rectangular type.**

## 5. RESULTS AND DISCUSSION

### STATIC ANALYSIS

Self-weight: The total weight of the frame is 20 kg (196.133N).

Engine Load: The total load of the engine which is acting on the chassis was found to be 40 kg (392.266N).

In the below figures the deformation and Stress that is induced on the Frame is shown.

Deformation: The maximum deformation obtained during the analysis is "0.24973 mm" at the rear section of the frame.

Stress: The maximum stress obtained during the analysis is "65.277 Mpa" at the tapering section.

## 4. COST EXPENDITURE

PRODUCTS	COST
Mild steel angle	Rs 700
Plummer block	Rs 400
Engine (Activa 110cc)	Rs 6000
Shaft	Rs 300
Wheels+front spokes	Rs 2500
Sprockets (2) and chain	Rs 1000
Fuel tank	Rs 450
Rubber handle	Rs 400
Mild steel pipe + bending	Rs 500
Bolts and nuts	Rs 700
Chain guard	Rs 300
Tool holder	Rs 800
Battery 12v	RS700
Others	Rs 5000
<b>TOTAL</b>	<b>Rs 19750</b>

**Table 1 Cost Expenditure**

## 6. Conclusions

The purpose of our project is to design and develop a harrowing machine of low cost. The harrowing machine is an alternate to conventional harrowing where bullocks are used to drag the harrowing tool.

Harrowing machine is simple in design, low weight, requires less maintenance, easy to use and is of low cost compared to power tiller. An added advantage of harrowing machine is that, it is provided with a seating arrangement for the user to drive the machine, so user is at comfort. Also unlike a power tiller, it can be used before & after seedling stage as the wheel width of developed machine is less compared to that of power tiller.

A static analysis was carried in addition to fabrication for knowing the stresses developed in the frame. The total deformation under maximum stresses can also be explained from static analysis. The analysis results are analyzed & used to modify and develop design.

The project also has scope for further improvements in the areas such as adjustment of harrowing tool for all crop width, an integrated machine which facilitates harrowing, ploughing, spraying, and weeding. So, by this we conclude that the harrowing machine which we have fabricated is unique and can have many more advantages compared to other equipments available in the market as per cost and size.

## Future Scope

The equipment can be reconstructed by using better resources, considering the quality required for the market. The equipment design can be varied to meet the requirements of other crops such as horse gram, ground nut etc.

The equipment can also be provided with certain means to use other tools such as a plough.

The equipment can be modified to use as grass cutter, pesticide sprayer.

The equipment material requirement cost can be reduced by manufacturing in large quantities

## Acknowledgments

Department of Industrial Engineering and Management Department, BMS College of Engineering.

Department of Mechanical Engineering Department, Global Academy of Technology.

## References

- [1] Jean-Martin Fortier. "The rotary power harrow", Farm Start tool Shed.
- [2] R JaffarSadiq, 2Dr.S.G.Gopalakrishna, 3Dr.N.G.S.Udupa "DESIGN AND FABRICATION OF MULTI PURPOSE AGRICULTURAL EQUIPMENT".
- [3] T. Ramachandran, K. P. Padmanaban, "REVIEW ON INTERNAL COMBUSTION ENGINE VIBRATIONS AND MOUNTINGS".
- [4] Jean Gimpel. The Medieval Machine. P.53.