

# Study on Comparison Analysis of Circular and Intze Water Tank on Sloping Ground

I.R. Saudagar<sup>1</sup>, A.N. Shaikh<sup>2</sup>

<sup>1</sup>M.E Student, Dept. of Civil Engineering, M.S. Bidve Engineering College, Latur-413512, Maharashtra, India.

<sup>2</sup>Assistant Professor, Dept. of Civil Engineering, M.S. Bidve Engineering College, Latur-413512, Maharashtra, India

\*\*\*

**Abstract** - The present study concerned with the performance of two types of elevated water tank with varying slopes by Response Spectrum Analysis on varying slopes. It is carried out by considering various parameters like water storage capacity and staging height which are constant, various types of staging arrangement and variation in the ground slope. By intercombining each of these parameters ten models of tank were created. All tank models have their locality in earthquake zone III. Dynamic response of elevated water tanks is hard to define, as the behavior of tank is unpredictable. All tank models are analyzed by Etabs software to study the effect of time periods, maximum displacement, base shear and base moment.

**Key Words:** Elevated circular and intze water tanks, Response Spectrum Analysis, earthquake, Etabs software

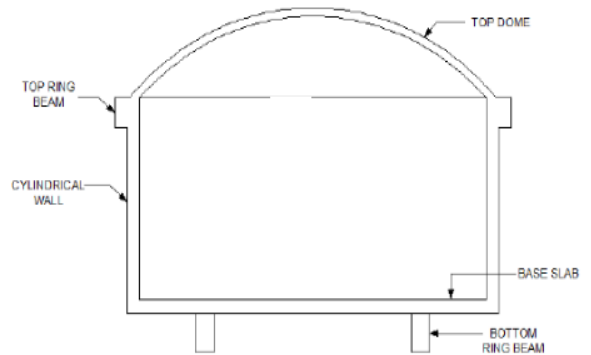

Fig -2: General diagram of Circular water tank

## 1. INTRODUCTION

The present study investigates the behavior of elevated circular water tanks and intze water tanks by Response Spectrum Analysis on varying slopes. It is carried out by considering various parameters like water storage capacity and staging height which are constant, various types of staging arrangement and variation in the ground slope. Dynamic analysis of liquid storage tank is a complex problem involving water- structure interaction. Based on numerous analytical, numerical and experimental studies, simple etabs models of tank- liquid system have been developed to calculate the hydrodynamic forces. During the earthquake, water contained in the tank exerts forces on tank wall as well as bottom of the tank. These hydrodynamic forces should consider in the analysis in addition to hydrostatic forces This project is concerned with the performance of two types of elevated water tank with varying slopes under seismic and wind induced dynamic loads as shown below in the fig.1 and fig.2

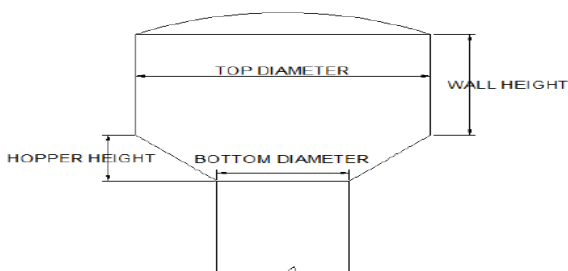

Fig -1: General diagram of intze water tank

## 1.1 Objectives

The objectives of this study are listed below-

1. To study the effectiveness of supporting system of elevated water tanks with different alteration and seismic response of tank on varying sloping ground.
2. To carry out modeling and response spectrum analysis of circular and intze water tank on sloping ground by using etabs software.
3. Dynamic response of these elevated water tank in terms of base shear, base moment, time periods and maximum displacement are found out using response spectrum analysis.
4. Compare the response of circular and Intze water tank on varying sloping ground and normal ground conditions.

## 1.2 Need of the Study

Indian sub-continent is highly vulnerable to natural disasters like earthquake, draughts, floods, cyclones etc. According to IS code 1893 (Part 1):2000, more than 60% of India is prone to earthquakes. The earthquake of 26 January 2010 in Gujarat was unprecedented for the entire country, then public learnt first time that the scale of disaster could have been far lower had the construction in the region complied with codes of practice for earthquake prone regions. These natural calamities are causing many casualties and innumerable property loss every year. After an earthquake the loss which cannot be recovered are the life loss. Collapse of structures causes people to life loss. Hence

badly constructed structures kill people more than earthquake itself. Hence it becomes important to analyze the structures properly. Seismic safety of liquid storage tanks is of considerable importance, as tanks storing highly concentrated liquids in industries, or in transporting vehicles, ships can cause considerable harm for human society if damaged.

### 1.3 Methodology

Following method is adopted for the analysis. The primary data was gathered through a Literature survey targeted by web searches and review of eBooks, manuals, codes and journal papers. After reviewing the problem statement is defined and model preparation is taken up for detail study and analysis purposes. This project execution follows the flow chart given below  
The following flow chart describes the layout of this project briefly:

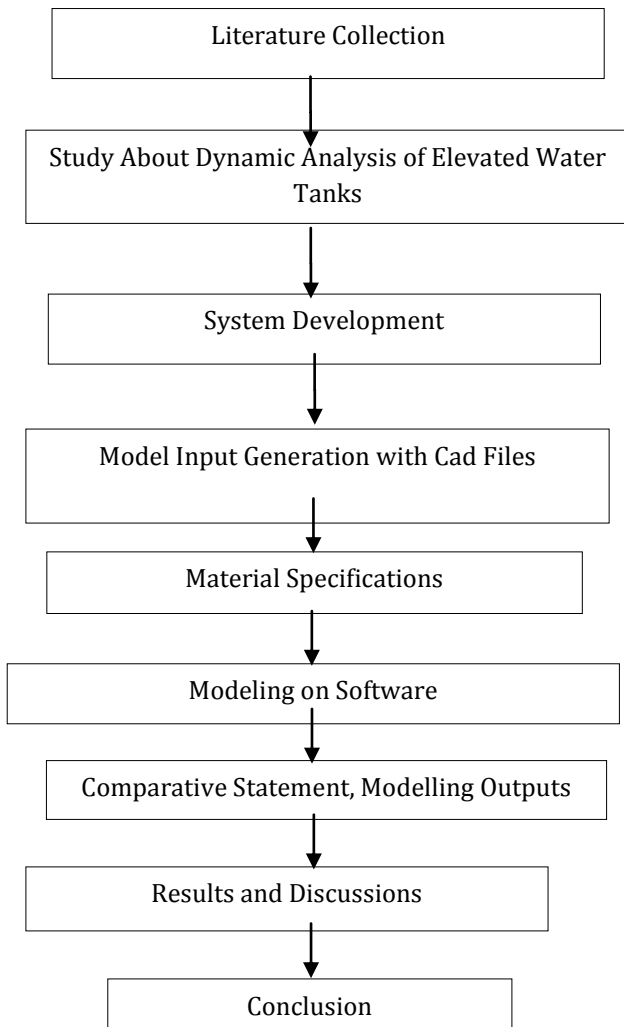

## 2. MATERIALS AND METHODS

### 2.1 Model Details

The current work is focused on the Comparative Study of circular and intze type of overhead water tanks. The configuration involves the same diameter and capacity of tanks but proposed on varying slopes and in the same earthquake zone. It is carried out by considering various parameters like water storage capacity and staging height which is vary on the ground slope and then, detailed analysis will be carried out in Etabs. Ten models are prepared in this study for the analysis and study. The types of elevated water tank considering for analysis and modeling are as follows:

1. Circular water tank
2. Intze water tank

The constant parameters in all the ten models are as below:

**Table -1** Description of models for analysis of Elevated Water Tank

Sr. No.	Description	Circular tank	Intze Tank
1.	Diameter of Column	450mm	450mm
2.	Height of wall (m)	3m	3m
3.	Hopper height (m)	NA	2m
4.	Height of Staging	12m	12m
5.	Bracings	225x300mm	225x300mm
6.	Thickness of Roof Slab	200mm	200mm
7.	Thickness of Floor slab	450mm	450mm
8.	Size of top beam	300x300 mm	300x300 mm
9.	Thickness of wall	300mm	300mm
10.	Size of bottom beam	450x800mm	450x800mm
11.	Staging level	4	4
12.	Type of soil	Medium soil	Medium soil
13.	No of Column	8	8
14.	Top diameter of tank	4m	4m
15.	Bottom diameter of tank	NA	2m
16.	Type of bracing	Normal	Normal,
17.	Unit Weights	Concrete = 25 KN/m <sup>3</sup>	Concrete = 25 KN/m <sup>3</sup>
18.	Material	M25 Grade Concrete & Fe415	M25 Grade Concrete & Fe415

**Table -2** Loading according to IS 875-Part 1, Part2 and Part 3

Sr. No.	Parameter	Values
1.	Impose load	5 kN/m <sup>2</sup>
2.	Super dead load	2.75 kN/m <sup>2</sup>
3.	Basic wind speed (V <sub>b</sub> )	33m/sec
4.	Windward coefficient c <sub>p</sub>	0.8
5.	Leeward coefficient c <sub>p</sub>	0.5
6.	Risk coefficient k <sub>1</sub>	1
7.	Topography	1
8.	Importance factor (Wind)	1
9.	Surcharge load for circular water tank	= $\gamma_d$ = 10x2.75 = 27.5 kN/m <sup>2</sup>
10.	Surcharge load for intze water tank	= $\gamma_d$ = 10x4.75 = 47.5 kN/m <sup>2</sup>

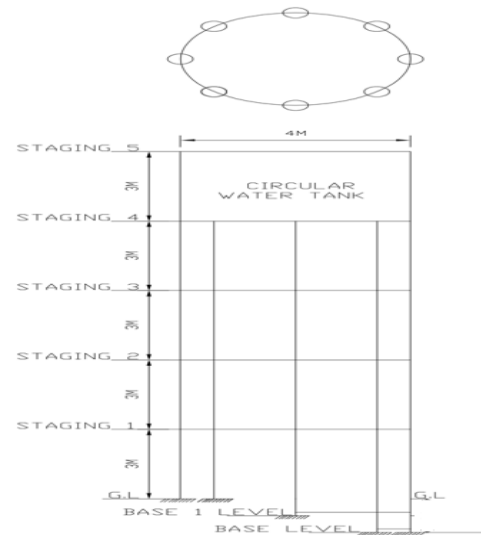

**Fig-3** Structure Elevation of circular water tank. Details input in Etabs Software for 0°, 5°, 10°, 15°, 20° configurations of circular water tank.

**Table-3** Seismic data required for analysis as per IS 1893 Part 1, Part 2

Sr. No	Parameter	Values
1	Seismic zone	III
2	Zone factor Z	0.16
3	Importance factor I (Earthquake)	1.5
4	Response reduction factor	1.8
5	Damping ratio	0.05
6	Type of soil	Medium

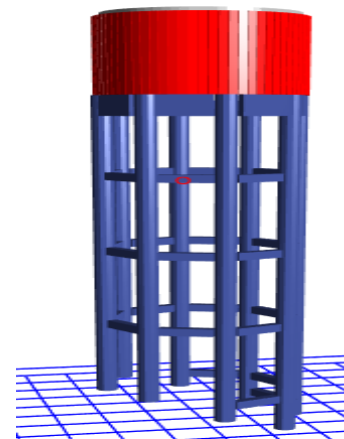
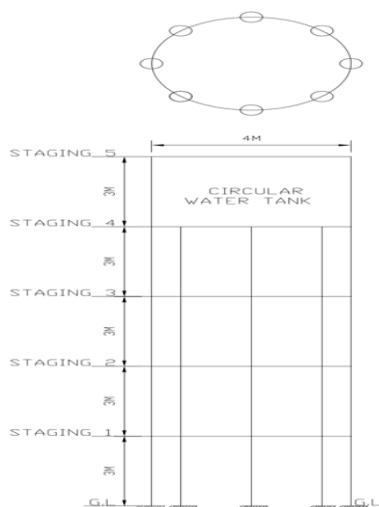
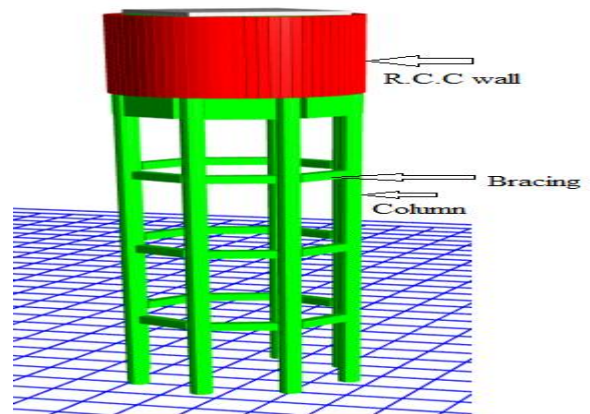

**Fig-4** Typical 3d model Structure of circular water tank. Details input in Etabs Software for 0°, 5°, 10°, 15°, 20° configurations of circular water tank.

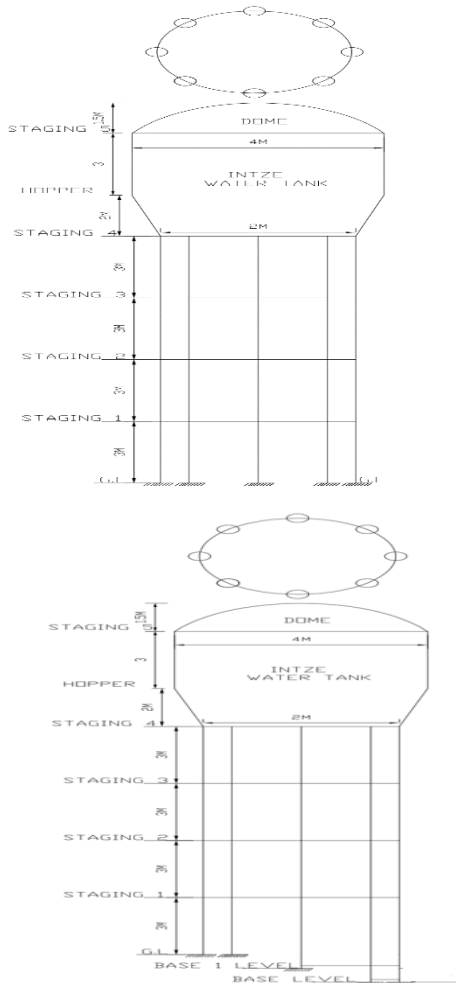

**Fig-5** Structure Elevation of intze water tank. Details input in Etabs Software for 0°, 5°, 10°, 15°, 20° configurations of intze water tank.

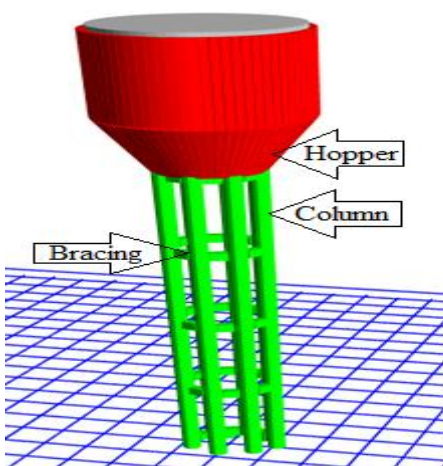

**Fig-6** Typical 3d model Structure of intze water tank. Details input in Etabs Software for 0°, 5°, 10°, 15°, 20° configurations of intze water tank.

### 3. RESULTS AND DISCUSSION

The maximum responses are determined for different parameters of elevated water tanks. Response spectrum analysis for the full tank condition in seismic zones III is carried out by using Etabs software. These responses include base shear force, base moment, maximum displacement and time periods.

#### 3.1 Base Shear (in kN)

Base shear values for Circular and Intze models are obtained using Response spectrum analysis from the ETABS software

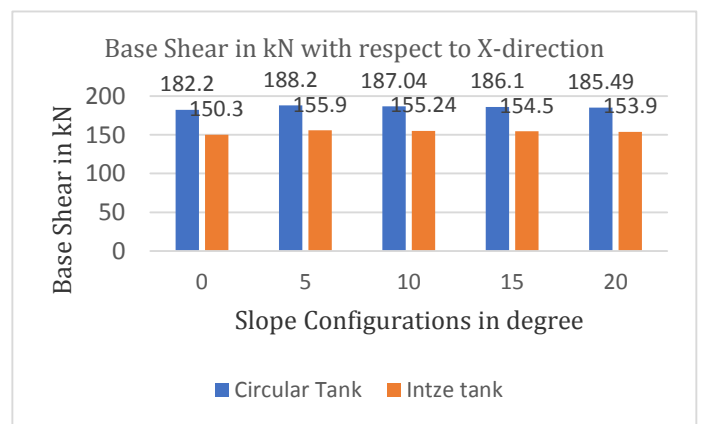

**Chart -1:** Base Shear in kN with respect to X-direction

Discussion on the Base Shear values on the models

The base shear for Circular tank is 33.74 % more than that of Intze water tank for slope cases of 0° -20° in seismic zone III.

### 3.1 Base Moment (in kN-m)

Base moment values for circular and Intze models are obtained using Response spectrum analysis from the ETABS software

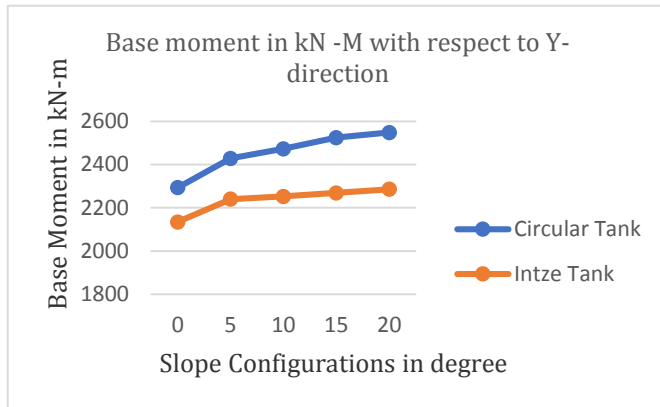

**Chart-2:** Base moment in kN-m with respect to Y-direction

Discussion on the Base moment values on the modals

The base moment for Circular tank is 8.82% more than that of Intze water tank for slope cases of 0<sup>0</sup> -20<sup>0</sup> in seismic zone III.

### 3.3 Maximum Displacements

Maximum Displacement values for circular and Intze models are obtained from Response spectrum analysis from the ETABS software under seismic zones III for Staging 5 levels of water.

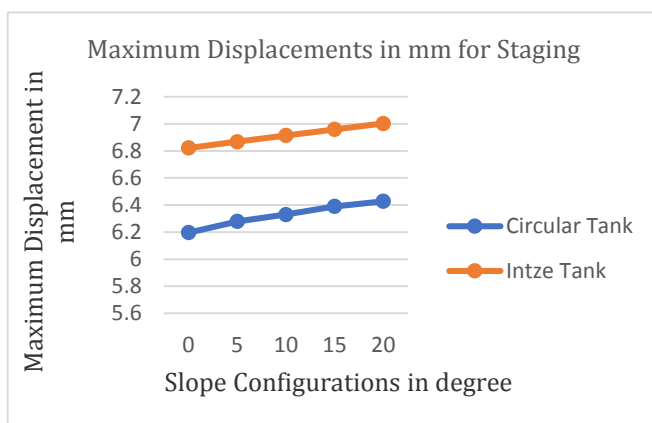

**Chart-3:** Maximum Displacements in circular tank and Intze tank

Discussion on the Maximum displacements on the modals

1. The maximum displacement usually occurs at top most staging 5 levels
2. The maximum displacement for Intze type of tank is 8.49 % more than that of circular tank for slope cases of 0<sup>0</sup> -20<sup>0</sup> in seismic zone III.

### 3.4 Time Periods

The time period is calculated for convective mode where in the liquid mass in the upper region undergoes sloshing motion this mass is called as convective liquid mass and it exerts convective hydrodynamic pressure on the tank and the base.

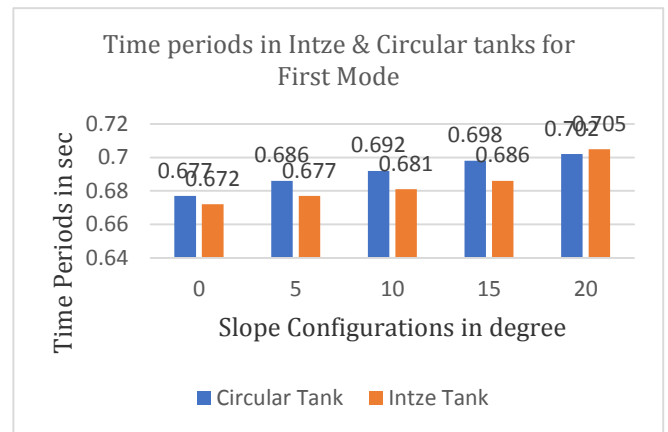

**Chart-4:** Time periods in Circular tank and Intze tank

Discussion on the time period of the models.

The time period for Circular tank is 0.98% more than that of Intze water tank for 0<sup>0</sup>-20<sup>0</sup> Slope Configurations modal.

### 4. CONCLUSIONS

1. The base shear for Circular tank is 33.74% more than that of Intze type of tank for full tank condition cases of 0<sup>0</sup> -20<sup>0</sup> in seismic zone III.
2. The base moment for Circular tank is 8.82% more than that of Intze water tank for slope cases of 0<sup>0</sup>-20<sup>0</sup> in seismic zone III.
3. The maximum displacement for Intze type of tank is 8.49 % more than that of circular tank for slope cases of 0<sup>0</sup>-20<sup>0</sup> in seismic zone III.
4. The time period for Circular tank is 0.98% more than that of Intze water tank for 0<sup>0</sup>-20<sup>0</sup> Slope Configurations modal.
5. For the sloping ground we saw that from our analysis for the parameter like shear force for all the cases in all the zones we found it was steeply rising to higher value as we move from column resting on lower side to column resting on higher side on a sloping surface
6. Design of water tank is a very tedious method. Particularly design of elevated cylindrical water tank involves lots of mathematical formulae and calculation. It is also time consuming
7. Large capacities water tanks are economical. On account of circular shape, it can make water tight easily as there as no sharp corners.
8. Time period for all ten models are different but approximate formula given by Is 1893-2000 is depend on height only .Therefore formula given

in IS1893-2000 need modification for irregular structure

## ACKNOWLEDGEMENT

I am thankful to my guide Prof. A.N. Shaikh and Head of Department Prof.S.G. Deshpande in Civil Engineering Department for his constant encouragement and able guidance Prof. N. B. Khatod, Principal, M.S. Bidve Engineering College, Latur-412512, Maharashtra, India, for his support and facilities provided during the course. I would also like to thank all staff members of Civil Engineering Department. Also, I thank my parents, friends etc. for their continuous support in making this work complete.

## REFERENCES

- [1] Bojj.M. Ratam, U.R. Raju "Effect of Staging Height On the seismic performance of rc elevated water tank", International Research journal of engineering and Technology E-ISSN-2319-8753
- [2] T.d. Sandeep, "Comparative studies on elevated water tank due to dynamic loading", International Research journal of engineering and Technology, E-ISSN2395-0056
- [3] P. N. Dhage, M.M. Joshi, "Review Study on Comparison between Static and Dynamic Analysis of RCC Water Tank", International Journal of Research in Advent Technology (E-ISSN: 2321-9637) Special Issue National Conference "Convergence 2017", 09th April 2017
- [4] S. Soroushnia, T. Tafreshi, F. Omidinasab, N. Beheshtian, S. Soroushnia, "Seismic Performance of RC Elevated Water Tanks with Frame Staging and Exhibition Damage Pattern", Procedia Engineering 14 (2011) 3076-3087.
- [5] A. Nankar, R. Navale, S. Shrikant, G.A. Palve, "Evaluation of seismic forces on elevated water tank", International Research journal of engineering and Technology E-ISSN2395-0056
- [6] D. Virkhare, L. Vairagade, V. Nair, "The behavior of an elevated circular water tank by pushover analysis", International Research journal of engineering and Technology.
- [7] N.R. Patil, R.S. Talikoti, "Seismic Behavior of Elevated water tank", International Journal of Research in Engineering and Technology, eISSN: 231: 2321-7308.
- [8] A.M.Jabar ,H.S.Patel, "Seismic Behavior of elevated water tank under different staging pattern and earthquake characteristics", International Research journal of engineering and Technology E-ISSN2249-8974
- [9] I. Kapadia, N. Dholiya, P. Patel and N. Patel, "Parametric study of RCC staging (support Structure) for overhead water tanks as per IS: 3370", Volume 4, Issue 1, January -2017
- [10] S.C. Duttaa, S.K. Jainb, C.V.R. Murty, "Alternate tank staging configurations with reduced torsional vulnerability-Soil Dynamics and Earthquake Engineering" 19 (2000) 199-215
- [11] IS 456:2000, "Indian Standard for Plain and Reinforced Concrete - Code of Practice", Bureau of Indian Standards, New Delhi, 2000.
- [12] IS 1893:2016, "Indian Standard Code of Practice for Criteria for Earthquake Resistant Design of Structures", Part 1, General Provisions and Buildings, Bureau of Indian Standards, New Delhi, 2016
- [13] IS: 1893 (Part 2), (2002), Indian Standard Criteria for Earthquake Resistant Design of Structures, Liquid Retaining Tanks, Bureau of Indian Standards, New Delhi.
- [14] IS: 1893 (Part 4), (2002), Indian Standard Criteria for Earthquake Resistant Design of Structures, Industrial structures including stack-like structures Bureau of Indian Standards, New Delhi.
- [15] IS 875(Part 1):1987 Code of practice for design loads (other than earthquake) for buildings and structures Part 1 Dead loads - Unit weights of building material and stored materials (second revision) (Incorporating IS:1911-1967)
- [16] IS 875(Part 2):1987 Code of practice for design loads (other than earthquake) for buildings and structures: Part 2 Imposed loads (second revision)
- [17] IS 875(Part 3):1987 Code of practice for design loads (other than earthquake) for buildings and structures: Part 3 Wind loads (second revision)
- [18] ETABS 2016. Computers and Structures, Inc. Berkeley, California. International Code Council, Inc. International Building Code.