

Design and Analysis of Adaptive Neuro-Fuzzy Controller Based Pitch Angle Controlled Wind Turbine for PMSG System

Lavudya Anand¹, Prof. M. GopichandNaik², Mr. S. Rajendra Prasad³

¹Dept of Electrical Engineering, AU College of Engineering (A), Andhra University-Visakhapatnam

²Professor, Dept of Electrical Engineering, AU College of Engineering (A), Andhra University-Visakhapatnam

³Dept of Electrical Engineering, AU College of Engineering (A), Andhra University-Visakhapatnam

Abstract - This paper presents application of Adaptive Neuro Fuzzy Inference System (ANFIS) for Proportional Integral Controller based control scheme to enrich the performance of a Wind Energy Conversion System (WECS). The wind turbine drives a Permanent Magnet Synchronous Generator (PMSG), which is connected to the power grid through a frequency converter, Power Electronic Converters and Filter. A cascaded ANFIS-PI controller is introduced in Pitch Control Method to control the speed of wind turbine. ANFIS is a non-linear, adaptive, and ruggedness controller, which integrates the advantages of the Artificial Neural Network (ANN) and fuzzy. The Conventional PI controller based coordinated control scheme is easy and provides a good performance. But, with varying parameters of the grid, especially at the time of grid disturbance due to LLL Fault; the conventional PI controller cannot effectively control the system. To perform this online returning of parameters, ANFIS controller based coordinated control scheme is proposed here. MATLAB simulations are executed to check the effectiveness of the proposed ANFIS controller based coordinated control scheme on a typical arrangement of MW-size Wind Farm connected to a Grid. It has been noticed that at the time of grid disturbance, the reactive power requirement of the PMSG based WECS and rotor speed of the PMSG based WECS is efficiently controlled by the ANFIS based controller. The simulations have presented how advantageous an ANFIS based controller is over a conventional PI controller.

Key Words: ANFIS Controller, Pitch angle control, PMSG, WECS, PI controller.

1. INTRODUCTION

Worldwide, renewable energy sources such as wind, hydro, tidal, solar, etc. are considered as the reliable and prospective energy sources for electric power generation. The rise in fuel costs, the depletion fossil fuel, and the environment concerns have drawn the world's attention to renewable energy sources. In the present renewable energy sources, wind energy has become the most ascendant and competitive energy source for the forthcoming world due to its comparatively cost-effective, healthy environment, and frequently huge power. Global Wind Energy Council and Greenpeace International Report have stated that the global installed wind power reached 496.9 GW at the end of 2016. It is expected that the wind power will reach 2110 GW and supply up to 20% of the global electricity generation by

2030[2, 12, 13]. In the recent wind generation methods, the Variable-Speed Wind Generators (VSWGs) have acquired great concerns and become most suitable for the wind energy applications. This attention is due to the few merits that the Variable-Speed Wind Generators (VSWGs) offered such as improved power Capture, low acoustical noise, lesser mechanical stress, greater control capability, and higher efficiency than that of the stable speed. Various types of electrical generators/generator are presently used as VSWGs Such as Permanent-Magnet-Synchronous-Generator (PMSG), Switched Reluctance Generator (SRG), Doubly Fed Induction Generator (DFIG), and due to the high-power density, self-excitation, and high-power factor operation, the PMSG-based wind generation system plays a major role in wind energy applications. PMSG needs a less maintenance, have less losses and cost, and have high efficiency, with the gearless construction. The wind turbine (WT) driven Permanent Magnet Synchronous Generator (PMSG) is cascaded to the power grid frequency converter (FC) which, in general, consists of back-to-back voltage source converters (VSCs) connected through a common DC-link. A Cascaded control pattern is widely entrenched for controlling the generator- and grid-side converter. This control technique is essentially based on the proportional-integral (PI) controllers and ANFIS based controller. Both grid side and generator side PI Controller will control always and another hand in wind turbine pitch angle controller will be operated by ANFIS based controller. Irrespective of these controllers and their extensive stability margins, they are extremely sensitive to non-linear system dynamics and their parameter differences. The setting of the PI controllers' parameters is very burdensome, specifically in engineering applications which have non-linear and higher-order systems. Many research attempts have been applied to fine-tune the PI controllers' parameters. Usually, Ziegler-Nichols and Newton-Raphson techniques are used to fine-tune the PI controller parameters. However, it is arduous to get the optimal performance using these methods, as they depend on the solver type and the initial conditions. From past few years the artificial intelligence control methods set a new trend to the classical control strategies to contract with the non-linear system dynamics. Fuzzy logic controllers (FLC) utilize the fuzzy logic as a design approach that can be applied to the embedded control systems for evolving the non-linear systems. The Fuzzy logic controllers (FLC) have easy mathematical design application and budget hardware technology. Anyhow, it majorly depends on the information

or knowledge and experience of the designer for fine tuning the membership functions (MFs). Hence, adaptive Fuzzy logic controllers (FLC) have been presented to adapt the input-output membership functions (MFs). The artificial neural network (ANN) controller has exposed in handling with the characteristics of system's nonlinearity. However, it agonizes from the large training procedure and convergence period. Now days, the integration of approaches offers the powerful trend to handle with these problems. The adaptive neuro fuzzy inference system (ANFIS) controller integrates the features and advantages of the ANN and the FIS in an individual model [2]. The ANFIS based controller encodes the fuzzy IF-THEN rules into a Neural Network based structure and then utilizes proper learning algorithms to reduce the output error based on the training data sets.

2. SYSTEM MODEL

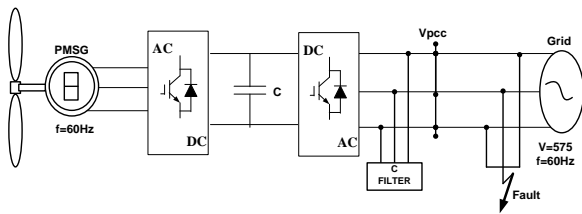

Fig -1: System Model

Fig -1: shows the system model of a typical wind farm considered in this simulation. It consists of permanent magnet synchronous generator (PMSG) which is connected to the Converter for controlling purpose. From the controlling point of view all the generated pulses will be given to the both converters. It also has a filter which is connected shunt to the infinite grid.

3. MODELLING OF WIND TURBINE

The wind turbine is utilized for the conversion of wind kinetic energy to mechanical work. On the foundation of relationships for the calculation, it is possible to state the value P_m of the aerodynamic wind turbine power.

$$P_m = 0.5 \rho A v^3 C_p(\lambda, \beta) \tag{1}$$

From above equation (1) ρ is the air density, (Area) $A = \pi R^2$ is the blades removed of the turbine, v is wind speed, and $C_p(\lambda, \beta)$ is the power coefficient, which states the relationship between the tip speed ratio λ and the pitch angle β .

$$C_p(\lambda, \beta) = C_1 \left(\frac{C_2}{\gamma} - C_3 \beta - C_4 \right) e^{\left(\frac{C_5}{\gamma} \right)} \tag{2}$$

The power coefficient is as is as $C_p(\lambda, \beta)$. with

$$\frac{1}{\gamma} = \frac{1}{\lambda + 0.089} - \frac{0.035}{\beta^3 + 1} \tag{3}$$

The relationship between the wind speed and the rotor speed is defined as tip speed ratio:

$$\lambda = \frac{R \cdot \omega}{v} \tag{4}$$

Where ω is the blades angular velocity and R is the rotor radius. From the value of the rotational motion performance, it is possible to determine the value of the torque T_m acting on the shaft as follows

$$T_m = \frac{P_m}{\omega} \tag{5}$$

These formulations are obvious that the instantaneous values of the performance of the mechanical torque are dependent on the wind speed closely. On the basis of these formulations, it is possible to figure the model, which structure of the wind turbine in MATLAB Simulink environment.

Fig -2: shows the power wind turbine coefficient curves. It reveals C_p that attains the maximum value at the particular λ_{opt} [3, 4].

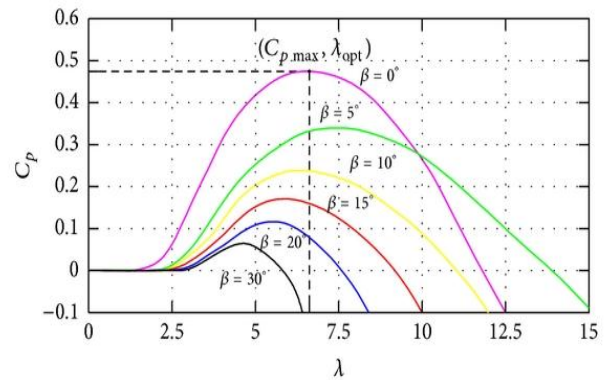

Fig -2: The power wind turbine coefficient curves.

Fig -3: shows that the rotational speed is a function, in which the power taken in wind turbine blade attains the maximum output at the specific rotational speed, while the pitch angle is constant. Therefore, it should be kept at to maximize the wind energy.

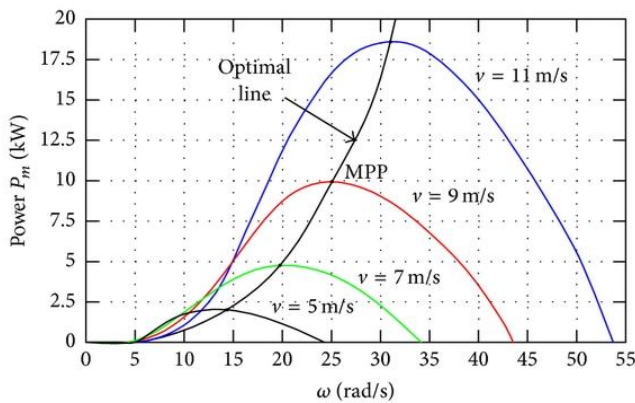

Fig -3: The relationship between power and wind speed curves

4. SELF CONTROL OF PMSG WIND TURBINE

4.1 GENERATOR SIDE CONVERTER

The generator-side converter is controlled to catch extreme power from available wind power. In order to control the electromagnetic torque T_e , this study just controls the q-axis current i_{sq} with the assumption that the d-axis current i_{sd} is equal to zero. Likewise, it shows in order to catch extreme power, the optimum value of the rotation speed is attuned [4]. The tip speed ratio λ is taken into account due to the equation being represented in the equation (6).

$$\omega_{ref} = \frac{\lambda_{opt} \cdot v}{R} \tag{6}$$

ω_{ref} is the blades angular velocity reference and λ_{opt} is the tip speed ratio optimum [4]. It is calculated that

$$U_{sd} = R_{sa} i_{sd} - \omega_s L_{sq} i_{sq} + \frac{di_{sd}}{dt} L_{sd}$$

$$U_{sq} = R_{sa} i_{sq} - \omega_s L_{sd} i_{sd} + \frac{di_{sq}}{dt} L_{sq} + E_s \tag{7}$$

With $E_s = \omega_s \psi_p$ being the permanent flux linkages.

The Generator side control can be designed on field oriented control basis. The performances of controllers are good for the synchronous reference frame. This controller monitors and control the system dq component of current where d-axis current correlates to active power and q-axis current corresponds to reactive power.

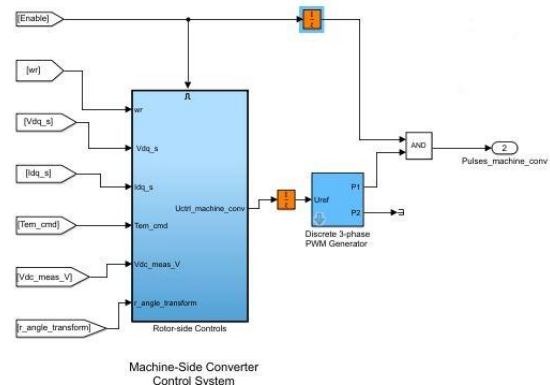

Fig -4: Generator side converter control system.

4.2 GRID SIDE CONVERTER

In the grid-side converter, a control technique with a reference frame associated along the converter ac voltage is adopted, so the active power and reactive power supplied from PMSG-WT to the grid can be independently controlled. The grid-side converter takes benefit of two outer Proportional-integral (PI) control loops that define reference values i_d and i_q for two inner current control loops that control the d- and q-axis decoupling current components. In the meantime, the inner current control loops evaluate the PWM modulation indices for the converter control. In this way, a grid-side converter is able to sustain the DC-link voltage stable and control the reactive power at the preferred value. To this externally, once the reference value of reactive power is set as zero, the converter or inverter can operate in unity power factor mode to yield the extreme active power output [6-8, 15, 16].

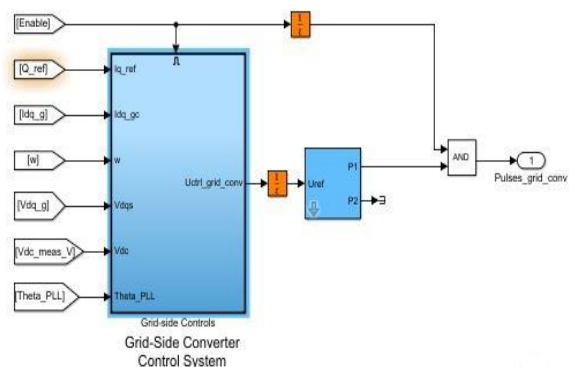

Fig -5: Grid side converter control system.

4.3 PITCH CONTROL

In pitch controlled wind turbines the power sensor senses the output power of the turbine. When the output power reaches above the extreme rating of the machine, the output power sensor drives a signal to the blade pitch mechanism which suddenly pitches (turns) the rotor blades slightly out of the wind.

Pitch-control mode: For greater than rated wind speeds but below the cut-out limit, the captured power is kept constant by the pitch mechanism to protect the turbine from destruction while the system generates and supplies the rated power to the grid. The blades are pitched out of the wind progressively with the wind speed, and the generator speed is controlled consequently. When the wind speed goes the cut-out speed, the blades are pitched entirely out of the wind. No power is captured, and turbine speed is decreased to zero. The turbine will be inaccessible into the parking mode to avoid damage from the strong wind.

5. ANFIS DESIGN

An adaptive neuro-fuzzy inference system or adaptive network-based fuzzy inference system (ANFIS) is a kind of artificial neural network that is based on Takagi–Sugeno fuzzy inference system. The technique was developed in the early 1990s. A neuro-fuzzy technique called Adaptive network based fuzzy inference system (ANFIS) has been used as a prime tool in the present work. An Adaptive Network Based Fuzzy Inference System (ANFIS) is a data driven process representing a neural network approach for the solution of function approximation problems. The driven data processes for the synthesis of ANFIS networks are typically based on clustering a training set of numerical samples of the unidentified function to be estimated. Since introduction, ANFIS networks have been magnificently applied to classification tasks, rule-based process control, pattern recognition and related problems. Here a fuzzy inference system contains of the fuzzy model proposed by Takagi, Sugeno and Kang to formalize a systematic approach to generate fuzzy rules from an input output data set [5, 9, 14].

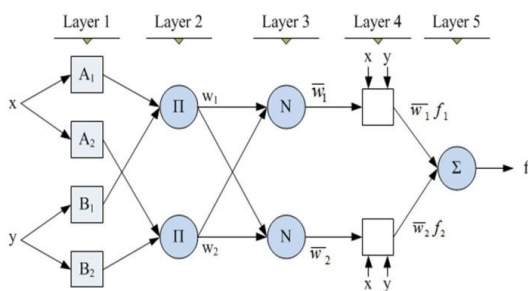

Fig -6: Typical five-layered ANFIS structure

The Adaptive Network Based Fuzzy Inference System (ANFIS) structure for easiness, it is implicit that the fuzzy inference system under consideration has two inputs and one output. The rule base contains the fuzzy if-then rules of Takagi and Sugeno’s type as follows: If x is A and y is B then z is f(x,y), Here A and B are the fuzzy sets in the antecedents and z = f(x, y) is a crisp function in the consequent. Generally f(x, y) is a polynomial for the input variables x and y. But it can also be any other function that can approximately represent the output of the system within the fuzzy region as quantified by the antecedent. When f(x,y) is a constant, a

zero order Sugeno fuzzy model is formed which may be considered to be a special case of Mamdani fuzzy inference system where each rule consequent is specified by a fuzzy singleton. If f(x,y) is reserved to be a first order polynomial a first order Sugeno fuzzy model is formed[10].

For a first order two rule Sugeno fuzzy inference system, the two rules may be shown as:

Rule 1: If x is A₁ and y is B₁ then f₁=p₁x + q₁y + r₁

Rule 2: If x is A₂ and y is B₂ then f₂=p₂x + q₂y + r₂

In this inference system the output of each rule is a linear combination of the input variables added by a constant term [11]. The last output is the weighted average of each rules output. The equivalent ANFIS structure is shown in Fig 6. The individual layers of this ANFIS structure are defined below:

Layer 1: Every node ‘i’ in this layer is adaptive with a node function

$$O_i^1 = \mu A_i(x)$$

Where, **x** is the input to node ‘i’, A_i is the linguistic variable allied with this node function and μA_i is the membership function of A_i. Usually $\mu A_i(x)$ is chosen as

$$\mu A_i(x) = \frac{1}{1 + \left[\left(\frac{x - c_i}{a_i} \right)^2 \right]^{b_i}}$$

Or
$$\mu A_i(x) = \exp \left\{ - \left(\frac{x - c_i}{a_i} \right)^2 \right\}$$

Where **x** is the input and {a_i, b_i, c_i} is the principle parameter set.

Layer 2: Each node in this layer is a static node which calculates the firing strength ω_i of a rule. The output of every node will multiply with all the incoming signals to it and is given by,

$$O_i^2 = \omega_i = \mu A_i(x) \times \mu B_i(y) \quad i = 1,2$$

Layer 3: Every node in this layer is a fixed node. Each ⁱth node calculates the ratio of the ⁱth rule’s firing strength to the sum of firing strengths of all the rules. The output from the ⁱth node is the normalized firing strength given by,

$$O_i^3 = \bar{\omega}_i = \frac{\omega_i}{\omega_1 + \omega_2} \quad i = 1,2$$

Layer 4: Each and every node in this layer is an adaptive node with a node function given by

$$O_i^4 = \overline{\omega}_i f_i = \overline{\omega}_i (p_i x + q_i y + r_i) \quad i = 1,2$$

Where $\overline{\omega}_i$ is the output of Layer 3 and $\{p_i, q_i, r_i\}$ is the consequent parameter set.

Layer 5: This layer comprises of only one static node that calculates the overall output as the summation of all incoming signals, i.e.

$$O_i^5 = \text{overall input} = \sum_i \overline{\omega}_i f_i = \frac{\sum_i \overline{\omega}_i f_i}{\omega_i}$$

6. RESULTS AND ANALYSIS

The model which is examined under LLL fault condition with conventional PI controller and ANFIS based controller in a grid connected wind farm. It is simulated for a period of 3.3 seconds and the simulation is carried out using solver ode45 in MATLAB R2018a environment. The wind turbine have a nominal wind rating of 12m/s and DC link voltage of 1150V, Grid peak voltage of 575V, rated power 1.5MVA and frequency of 60Hz initially. Due to fault at the point of common coupling at t=0.6 to 0.8 disturbance is created in the grid connected wind farm. A simulated result shows the performance of both conventional PI and ANFIS controller and it is observed that ANFIS controller exhibits better results than the conventional PI controller. The figure (7-18) gives the comparative analysis of rotor speed, mechanical torque, DC link voltage, active and reactive power, grid voltage and grid current with proposed and conventional PI controller.

6.1 RESULTS OF CONVENTIONAL PI-CONTROLLER

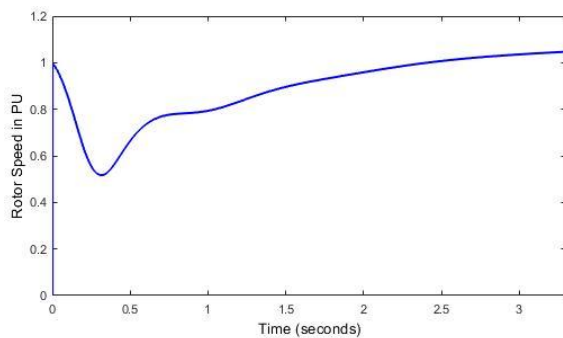

Fig -7: Rotor speed in Pu w.r.t time (Sec)

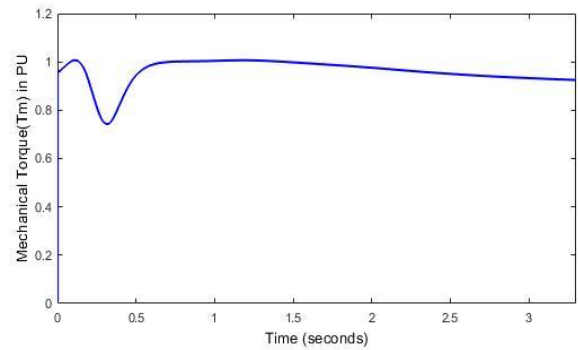

Fig 8: Mech.Torque in Pu w.r.t time(Sec)

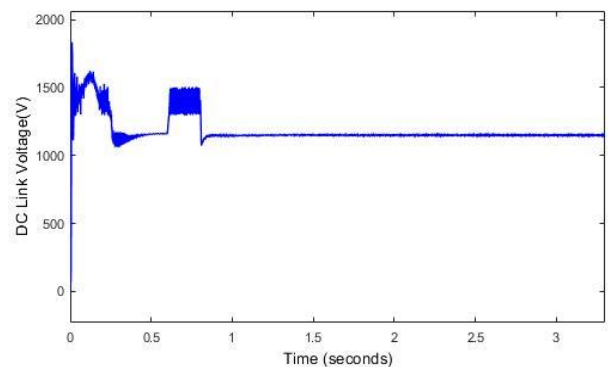

Fig 9: DC link Voltage w.r.t time (Sec)

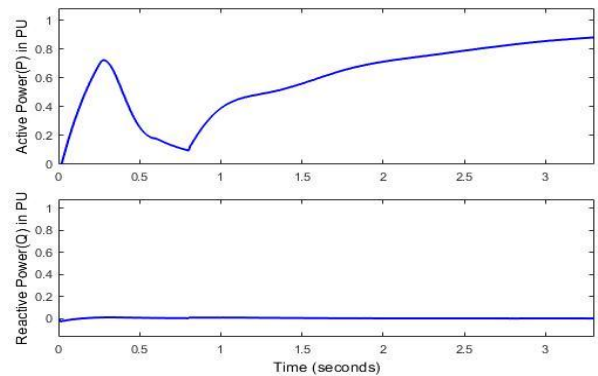

Fig 10: Active and Reactive Power in Pu w.r.t time (Sec)

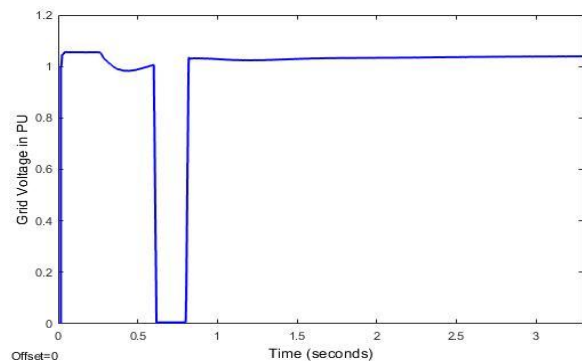

Fig 11: Grid Voltage in Pu w.r.t time(Sec)

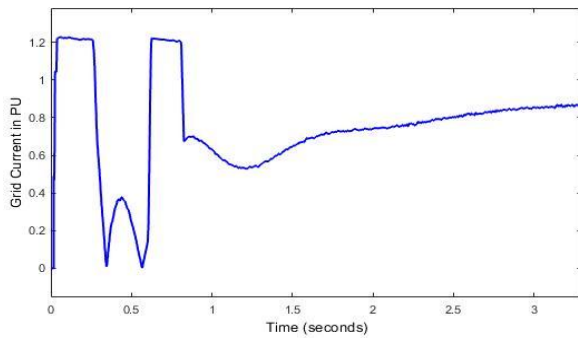

Fig 12: Grid current in Pu w.r.t time(Sec)

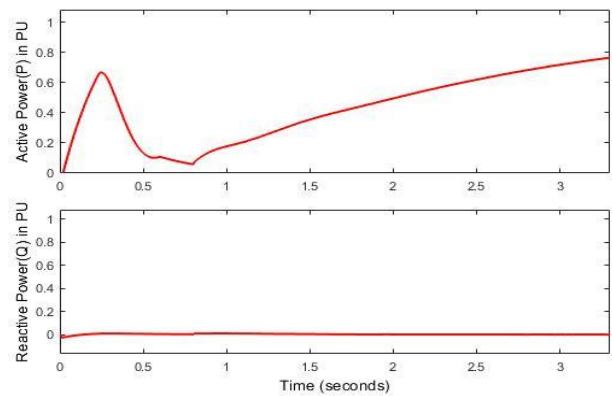

Fig 16: Active and Reactive Power in Pu w.r.t time(Sec)

6.2 RESULTS OF ANFIS-PI CONTROLLER

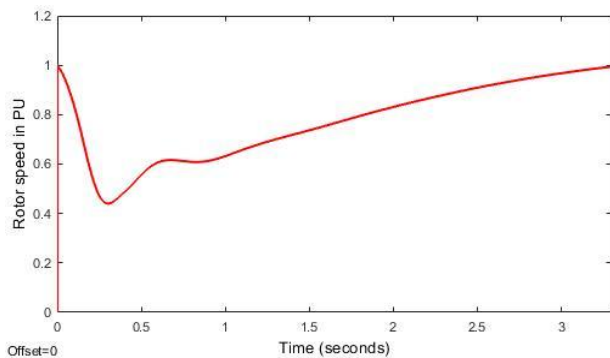

Fig 13: Rotor speed in Pu w.r.t time(Sec)

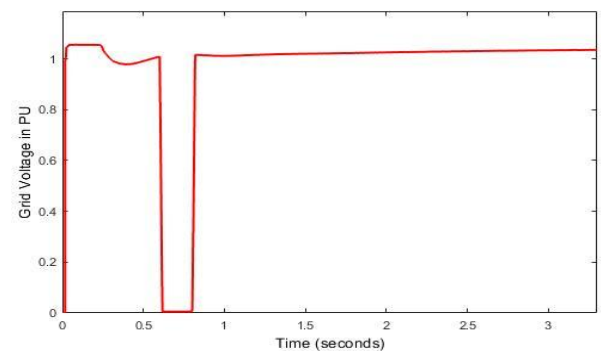

Fig 17: Grid Voltage in Pu w.r.t time(Sec)

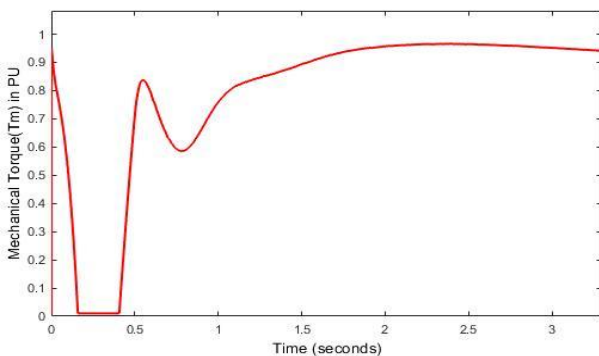

Fig 14: Mech.Torque in Pu w.r.t time(Sec)

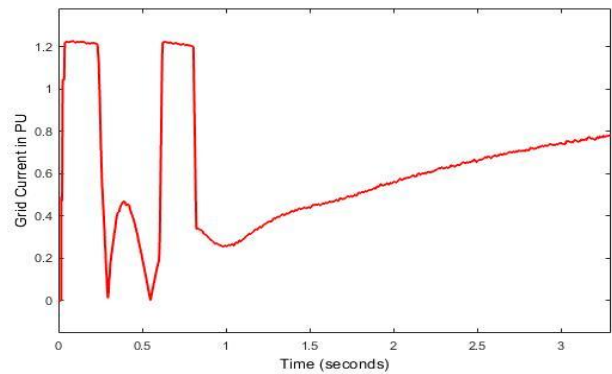

Fig 18: Grid current in Pu w.r.t time (Sec)

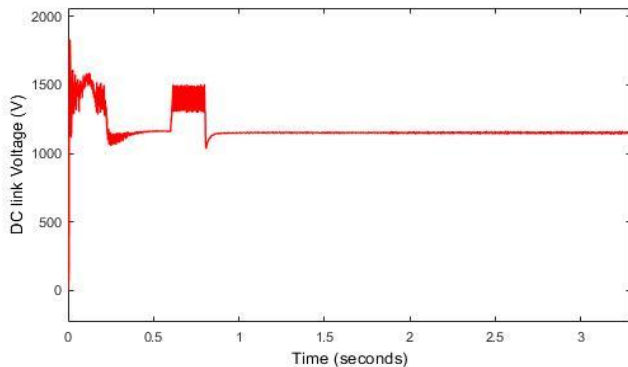

Fig 15: DC link Voltage w.r.t time (Sec)

Table -1: Comparison between various parameters

	Rotor Speed (Pu)	Mech. Torque (Pu)	DC link Voltage (V)	Active Power (Pu)	Reactive Power (Pu)
With Conventional PI Controller	1.047	0.9251	1141	0.8808	1.52×10^{-4}
With ANFIS-PI Controller	0.9943	0.9411	1143	0.7651	-2.3×10^{-4}

7. CONCLUSION

In this paper the dynamic performance (electrical and mechanical) of a PMSG based wind farm has been improved by implementing ANFIS based controller in contrast to conventional PI controller. When ANFIS based controller has been designed and implemented to improve the system performance in contrast to a conventional PI controller. The studies are carried out in MATLAB Simulink R2018a environment with solver ode45. This improvement has been shown with the help of various waveforms like rotor speed, mechanical torque, DC link voltage, active & reactive power, grid voltage and grid Current. It is concluded that the proposed ANFIS controller reduce the reactive power consumption and have better speed regulation.

8. REFERENCES

1. Aiman Khan*, Vivek Pahwa "Design and Implementation of ANFIS Based Controller on Variable Speed Isolated Wind-Diesel Hybrid System for Better Performance" American Journal of Electrical and Electronic Engineering, 2017, Vol. 5, No. 5, 172-178
2. Mahmoud A. Soliman₁, Hany M. Hasanien₂, Haitham Z. Azazi₁, Elwy E. El-kholy₁, Sabry A. Mahmoud₁ "Hybrid ANFIS-GA-based control scheme for performance enhancement of a gridconnected wind generator" IET Renew. Power Gener., 2018, Vol. 12 Iss. 7, pp. 832-843 © The Institution of Engineering and Technology 2018
3. A. W. Manyonge₁, R. M. Ochiengi₁, F. N. Onyango₁ and J. M. Shichikha₂ "Mathematical Modelling of Wind Turbine in a Wind Energy Conversion System: Power Coefficient Analysis" Applied Mathematical Sciences, Vol. 6, 2012, no. 91, 4527 - 4536
4. Chia-Nan Wang, Wen-Chang Lin, and Xuan-Khoa Le "Modelling of a PMSG Wind Turbine with Autonomous Control" Mathematical Problems in Engineering, Volume 2014, Article ID 856173
5. Dinesh Pipalava_{1,2}* and Chetan Kotwal₃ "ANFIS-PI Controller based Coordinated Control Scheme of Variable Speed PMSG based WECS to Improve LVRT Capability of Wind Farm Comprising Fixed Speed SCIG based WECS" Indian Journal of Science and Technology, Vol 9(44), DOI: 10.17485/ijst/2016/v9i44/95253, November 2016
6. Rahimi M, Parniania M, "Grid-fault ride-through analysis and control of wind turbines with doubly fed induction generators." Electrical Power System Research. 2010 Feb; 80(2)z; 184-95.
7. Nian H, Song Y, Zhou P, He Y, "Improved direct power control of a wind turbine driven doubly fed induction generator during transient grid voltage unbalance." IEEE Transaction Energy Conversion. 2011 Sep; 26(3): 976-86.
8. Chen-guang N, Guan-qi L. The Requirements and Technical Analysis of Low Voltage Ride-Through for the Doubly-Fed Induction Wind Turbines. ELSEVIER, Energy Procedia, The Proceedings of International Conference on Smart Grid and Clean Energy Technologies. 2011; 12:799-807.
9. M.V. Aware, A.G. Kothari "Application of adaptive neuro-fuzzy controller (ANFIS) for voltage source inverter fed induction motor drive" Power Electronics and Motion Control Conference, 2000. Proceedings. IPEMC 2000. The Third International, Volume: 2
10. N. Muruganatham, Palani Subbiah "Aaptive neuro fuzzy inference system based controller for high performance BLDC motor using softswitching inverter" Journal of theoretical and applied information technology 49(3):929-939. March 2013
11. Issam Grich, Sabir Messalti, Kamel Saoudi, Mohamed Y. Touafek "A New Adaptive Neuro-Fuzzy Inference System (ANFIS) and PI Controller to Voltage Regulation of Power System Equipped by Wind Turbine" European Journal of Electrical Engineering Vol. 21, No. 2, April, 2019, pp. 149-155
12. Global Wind Energy Council (GWEC): 'Annual market update 2015'. Global Wind Report. Available at <http://www.gwec.net>, accessed 31st December 2016
13. Global Wind Energy Council (GWEC): 'Global wind energy outlook 2016'. Available at <http://www.gwec.net>, accessed 31st December 2017
14. Hasanien Hany, M., Muyeen, S.M.: 'Affine projection algorithm based adaptive control scheme for operation of variable-speed wind generator', IET Gener. Transm. Distrib., 2015, 9, (16), pp. 2611-2616
15. Mohamed El-Shimy, Nisma Ghaly "Wind Energy Conversion Systems, Grid-Connected", Encyclopedia of Energy Engineering and Technology, Second Edition
16. Hasanien Hany, M., Muyeen, S.M.: 'Speed control of grid-connected switched reluctance generator driven by variable speed wind turbine using adaptive neural network controller', Electr. Power Syst. Res., 2012, 84, (1), pp. 206-213.