

GPS NAVIGATOR WITH NARRATION SYSTEM AND SECURITY ALERT

A.J. RANDHAVANE¹, Y.R. RATHOD², V.S. GUNJAL³, A.R. WAGH⁴

^{1,3,4}BE Student, Electronics and Telecommunication, SND COE & RC, Yeola, Maharashtra, India

⁴Asst. Prof., Electronics and Telecommunication, SND COE & RC, Yeola, Maharashtra, India

Abstract - Over the last twenty years or so have involved the development of some of the most innovative techniques in the science of geolocation. With evolving world of technological advancements, geolocation guide systems using radio-frequencies has gained a wide-spread attention compelling engineers to grab on the opportunity to make something big out of it. Theme parks/ national parks as well as other huge tourist attractions need directional guides to inform user about his location. To solve this issue we here propose a park guidance system using RF technology that works wirelessly to guide user about his current location. This proves as a very handy and convenient medium for guiding tourists through the park. This system proposes to replace, you are here boards mounted through such parks. The user may carry the circuit with him. It then consists of RF transmitters placed at various locations across the park.

Key Words: ATMEGA16A, RF receiver, RF Transmitter, GPS, GSM, Emergency Switch.

1. INTRODUCTION

In today's modern world there are various tourist guidance system available for tourist. In our project we have two aim, first is to guide the tourist in theme/national park as well as hug tourist places and second one is security alert for tourists. Our system uses an RF receiver circuit in order to track the user. The user may carry the circuit with him. It then consists of RF transmitters placed at various locations across the park. These transmitters constantly emit RF signals. When the RF receiver circuit carried by user comes in range on an RF transmitter it detects that the user is in range of that particular RF transmitter. This signals it to display the location of the user. Each location area is identified uniquely by an RF transmitter. When the user enters the area the circuit reads the transmitter code and displays the location on an LCD screen, and narrate information about that place to the user.

The global positioning system has become a common functionality in hand held devices, and therefore, several location-tracking applications have been developed for elders, woman and children for safety reasons. . The global system for mobile communications (GSM) modem and a GPS unit is used to track the location. In this project, we have used this GSM to communicate with the security in case of an emergency. Wireless communication is a transfer of information between two or more points that are not

connected by an electrical conductor. The most common wireless technologies use radio waves with radio waves distances can be short such as a few meters for Bluetooth or far as millions of kilometers for deep space radio communication. Here we have used RF transmitter and receiver. The range of RF frequency is 20 kHz to 300Ghz.It can cover up to a distance of 2 km.

2. METHODOLOGY

The block diagram and circuit diagram for that project is as follow

2.1 BLOCK-DIAGRAM

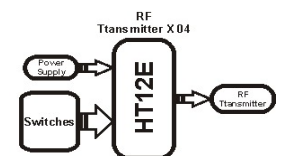
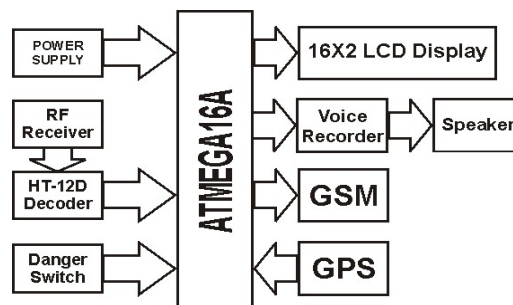

Fig.1: Circuit diagram of GPS navigator with security alert

The proposed system is divided into two sections, transmitter and receiver. The transmitter and receiver section of the system along with all the required components are shown in above diagram.

In the transmitter section of the system should be compact and small in size for the implementation in various locations of the area in which the system is used. This section consists of RF transmitter along with an encoder section. This transmitter section transmits the radio frequency signals towards the receivers through antenna connected with it. These transmitters are placed in the various locations in the field where the system is used. Each transmitter unit has a unique code to transmit. The system requires power supply

for its active functioning. The receiver section consists of a RF receiver having an antenna connected with it along with a decoder circuit. This RF receiver receives the radio frequency signal transmitted by the transmitter after decoded by the decoder.

The receiver section consists of a microcontroller, which is used to control and receive the data from the receiver and by processing it for the display purpose. This microcontroller collects data, process it and then display it on the display in the form which will be understood by the user.

Microcontroller requires power supply for the operation. A power supply unit is used to provide the required power to the circuit components in the system.

The receiver unit of the system consists of a GPS receiver interfaced with the microcontroller. This GPS receiver is used to obtain the geolocation of the user through satellite. The receiver receives the data from the satellite and provides it to the microcontroller. The microcontroller processes the received data and gives output in the co-ordinate form which consists of longitude and latitude value of the location. This unit also consists of a GSM modem interfaced with the microcontroller along with a switch named as Danger switch. This switch is used to intimate about the danger in case of the system user and the GSM modem is used to send alert message to the relatives of the person about the user's location and danger.

The receiver consists of a display unit as shown. This display unit is used to display the location of the user carrying the receiver of the system in the area in which the numbers of transmitters are placed at different locations. A 16*2 LCD display is used for this purpose

2.2 CIRCUIT DIAGRAM

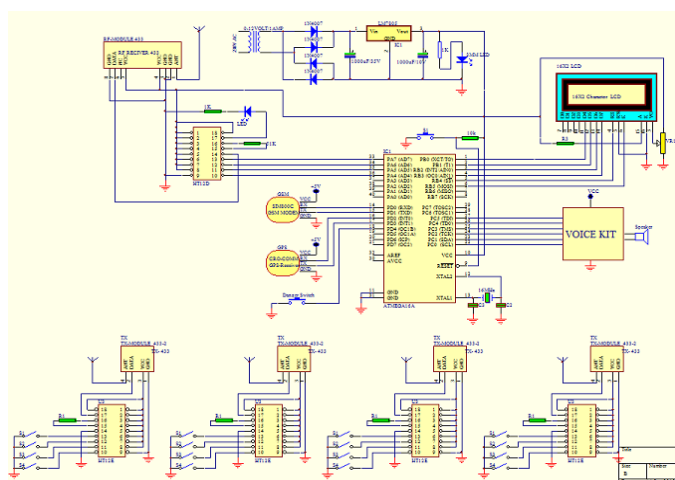

Fig. 2: Circuit diagram of GPS navigator with security alert

Above diagram shows the circuit implementation and interfacing of all the devices with the microcontroller in transmitter as well as receiver unit of the system. In this system number of transmitter section are implemented in the various sections. In this work 4 transmitter sections are used to display the location. Each transmitter section consists of a RF transmitter with encoder circuit as shown in the circuit diagram of the system. Here we have used a RF transmitter 433 module having working frequency of 433Hz. This transmitter module has 3 terminals VCC, GND and DATA and one antenna as shown in the circuit diagram. This transmitter section is used to transmit the RF signals towards the receiver section. An encoder HT12E IC is used to encode the data before transmitting it by the transmitter module.

In this project we have designed a RF receiver which is implemented on a bracelet. This bracelet is carried by the system user. The RF transmitter circuit will be placed in various location of that place say a tourist place. This transmitter will emit radio signals continuously. When a user, carrying the receiver circuit with him or her comes in the range of the transmitter, the receiver receives the signals and provides the location details to the user. Each transmitter has its own unique identification. The transmitter transmits a unique binary code which configurable and is generated by using switches as shown in the circuit diagram of the transmitter section. Each transmitter section consists of four switches depending on their state i.e. ON or OFF the binary code of that particular transmitter will be configured. The details about the user's current location will be display on the LCD display interfaced in the receiver circuit. The RF transmitter and receiver works on 433MHz frequency.

The receiver section consists of ATmega16A microcontroller, used for the controlling and to collect the data from the RF receiver. This is a 40 pin microcontroller. This microcontroller and some other components in the circuit require regulated power supply for their working purpose. To fulfil this power requirement of the circuit a power supply unit is designed and connected in the circuit. The power supply unit of the system consists of a step down transformer. The 230V mains supply is provided to the primary of the transformer and at the secondary it gives 12V stepped down supply. Since circuit works on DC supply, this obtained AC supply from the transformer needs to be converted into DC form. To perform this function a bridge rectifier circuit is designed and implemented in the power supply unit. This bridge rectifier circuit gives 12V DC supply at its output terminals. Microcontroller, LCD module and other components in the circuit works with 5V DC voltage. To obtain this regulated 5V DC voltage a LM 7805 voltage regulator IC is implemented in the circuit. 12V supply is provided to the input terminal of the IC and it gives regulated 5V DC at its output terminal. Two capacitors of

1000uf and 100uf are connected at input and output side of the IC respectively. These capacitors are used as filters to remove the AC ripples from the power supply and get smooth supply at the output. This regulated 5V DC supply is connected to the VCC pins of the microcontroller i.e. pin number 10 as shown in the circuit diagram. Pin number 11 and 31 of the microcontroller IC are GND pins and are connected to the ground terminal. The microcontroller used in the system can be reset to start the operation from a known state. To reset the microcontroller if required a reset switch is connected to the pin number 9 of the controller IC. After pressing this switch user can reset the controller and puts it to a known state i.e. will start operation from 00 memory location. The microcontroller requires machine cycles to execute the program instructions in the memory. To provide these machine cycles to the controller an external oscillator is connected to the microcontroller as shown in the circuit diagram. This oscillator is a crystal oscillator consists of a 16MHz quartz crystal and two 20pf capacitors connected in parallel form. This oscillator is interfaced with the pin number 12 and 13 of the microcontroller IC. The RF receiver module is interfaced to the port A of the controller IC as shown in the circuit diagram. The decoder circuit HT12D is connected to the pin number 33 to 36 of the controller IC which provides decoded binary signals to the controller IC. The RF receiver receives the data through the antenna and fed it to the decoder. This decoder decodes the radio frequency signals transmitted by the RF transmitter and encoded before the transmission by the encoder circuit in the transmitter section.

After receiving these signals the controller process the received data and converts it into the suitable form for the user to understand. After processing the data, the controller provides the data to the display unit for the display purpose. This display is interfaced in the receiver section on the bracelet as shown in the figure. This LCD display will show the names of the things which are the attraction of that particular area of the museum or in any historical place where the system is implemented to guide the tourists. In this system a 16x2 LCD display is interfaced with the microcontroller to display the various names. This LCD display is connected to the port B of the controller. The data lines D4 to D7 of the LCD display are connected to the pin number 1 to 4 of the controller IC. The RS pin of the display is connected to the pin number 5 in port B of the microcontroller. This pin is the register select pin. R/W i.e. read write pin of the display is connected to ground as shown in the circuit diagram. This is used to read the display data and write display data. E i.e. enable pin of the display is also connected to the port B pin number 6 of the controller IC. CS1 and CS2 are the chip select lines of the display used to select first half and second half of controller of LCD.

The receiver unit of the system consists of GPS receiver used to receive exact location of the user from the satellite. This

GPS receiver module consists of 4 terminals VCC, GND, TX and RX as shown. The VCC terminal is used to provide power supply to the module and GND terminal is connected to the ground. The RX and TX terminals are connected to the pin 16 and 17 of the controller IC respectively. This receiver receives data from the satellite and sends it to the controller through transmitter terminal.

This unit also consists of a danger switch connected to the pin number 18 of the controller IC as shown in the circuit diagram of the system. This switch is used to intimate the system about danger sensed by the user. This switch is to be used by the user manually.

A GSM modem is interfaced with the microcontroller as shown in the circuit diagram of the system. This GSM modem is used to send SMS to alert the relatives of the user about the danger and also to provide exact location of the user by sending location co-ordinates through SMS. Here we have used SIM800 GSM modem for the above mentioned purpose. This modem consists of 4 terminals VCC, GND, TX and RX. The VCC terminal is used to provide power supply to the module and GND terminal is connected to the ground. The RX and TX terminals are connected to the pin 14 and 15 of the controller IC respectively.

The system is designed in such a way that the name and details of the location where the user is present will be announced through voice announcement system. For this voice announcement feature of the system a voice recorder along with a speaker is interfaced with the microcontroller as shown in the circuit diagram. This announcement system is controlled by the microcontroller. The microcontroller sends data to this system for announcement.

ACKNOWLEDGEMENT

We feel great pleasure to present the Dissertation entitled "**GPS NAVIGATOR WITH NARRATION SYSTEM AND SECURITY ALERT**". But it would be unfair on our part if we do not acknowledge efforts of some of the people without the support of whom, this dissertation work would not have been a success.

First and for most we are very much thankful to our respected Guide **Prof. Wagh A.R.** for his leading guidance in this dissertation work. Also he has been persistent source of inspiration to us. We would like to express our sincere thanks and appreciation to **Prof. Patil S.T.** (HOD) for valuable support. Most importantly we would like to express our sincere gratitude towards our **Friends & Family** for always being there when we needed them most

REFERENCES

- [1] Proгри, I., "An assessment of indoor geolocation systems," Ph.D. Dissertation, Worcester Polytechnic Institute, May 2003.
- [2] Avagnina, D., Dovis, F., Ghiglione, A., and Mulassano, P., "Wireless networks based on high-altitude platforms for the provision of integrated navigation/communication services," IEEE Com. Mag., vol. 40, nr. 2, pp. 119-125, Feb. 2002.
- [3] Pahlavan, K., Li, X., and Makela, J.-P., "Indoor geolocation science and technology," IEEE Com. Mag., vol. 40, nr. 2, pp. 112-118, Feb. 2002.
- [4] IEEE P802.11 WG, Wireless LAN Medium Access Control (MAC) and Physical Layer (PHY) Specifications, 802-11: 1999 (ISO/IEC (IEEE Std 802.11, 1999 Edition) Information technology - Telecommunications and information exchange between systems - Local and metropolitan area networks - Specific requirements Part 11, 1999.
- [5] K. Cheverst, N. Davies, K. Mitchell, A. Friday, Experiences of developing and deploying a context-aware tourist guide: the GUIDE project. Proceedings of the 6Th annual international conference on Mobile computing and networking. ACM Press, 2000.
- [6] R. Want, A. Hopper, V. Falcao, J. Gibbons, The Active Badge Location System, ACM Transactions on Information Systems, 10:91-102, 1992
- [7] P. Bahl, V. Padmanabhan, RADAR: An In-Building RF- Based User Location and Tracking System, IEEE Infocom, Israel, March 2000.
- [8] Leonhardi, U. Kubach, An Architecture for a Distributed Universal Location Service. In Proceedings of the European Wireless '99 Conference: 1999.
- [9] M. Wallbaum, P. Dornbusch, Design Considerations for a Platform Supporting Location-Aware Services, Multimedia, Internet Video Technologies 2001 (MIV 2001), Malta, September 2001.

BIOGRAPHIES

Anmol J. Randhavane,
Department of Electronics and
Telecommunication
Engineering, SND COE Yeola,
Pune University.



Yogita R. Rathod, Department
of Electronics and
Telecommunication
Engineering, SND COE Yeola,
Pune University.



Vidya S. Gunjal, Department of
Electronics and
Telecommunication
Engineering, SND COE Yeola,
Pune University.



Prof. Amol R. Wagh,
Department of Electronics and
Telecommunication
Engineering. SND COE Yeola,
Pune University.