

DESIGN AND SIMULATION OF FUZZY LOGIC CONTROLLER BASED BI-DIRECTIONAL DC-DC CONVERTER

Mrs Anusree. M¹

¹Assistant professor, Rajiv Gandhi Institute of Technology, Karnataka, India

Abstract - This paper describes the design of a new non isolated bidirectional DC-DC converter. Bidirectional DC-DC converters are used to transfer the power between two DC sources in either direction. These converters are widely used in various industrial applications, such as hybrid electric vehicle energy systems, uninterrupted power supplies, fuel-cell hybrid power systems, PV hybrid power systems, battery chargers and satellites. The proposed converter employs a coupled inductor with same winding turns in the primary and secondary sides to avoid reverse recovery phenomenon, to achieve ripple free inductor current and to reduce voltage ripple. In step-up mode, the primary and secondary windings of the coupled inductor are operated in parallel-charge and series-discharge to achieve high step-up voltage gain. In step-down mode, the primary and secondary windings of the coupled inductor are operated in series-charge and parallel discharge to achieve high step-down voltage gain. Thus, the proposed converter has higher step-up and step-down voltage gains than the conventional bidirectional DC to DC boost/buck converter. Finally a 12/24-V prototype is simulated in MATLAB software and implemented to verify the performance of the proposed bidirectional DC-DC converter.

reduces the cost and improves efficiency, but also improves the performance of the system. Therefore a bidirectional DC - DC converter is needed.

1.1 Proposed Bi-directional DC-DC converter:

The proposed bidirectional dc-dc converter is shown in Fig. 2.1. The proposed converter employs a coupled inductor with same winding turns in the primary and secondary sides.

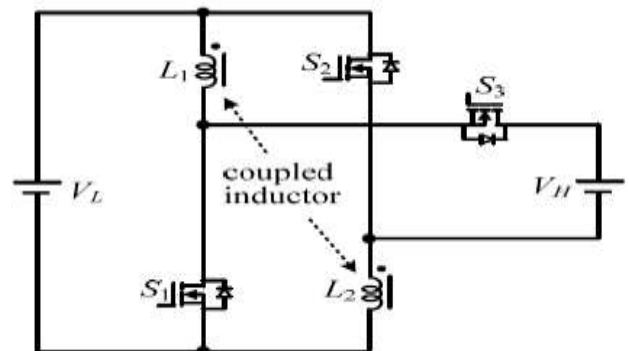

Fig - 1: Bidirectional dc-dc converter

Key Words: Proportional plus integral controller, Bidirectional convertor

1. INTRODUCTION

AC voltage or current is converted to DC for a wide variety of industrial applications and to withstand even the harshest of environments. However, as power conversion generates loss, reducing the number of conversions leads to energy conservation. Therefore, the introduction of DC power supply systems that supply DC power instead of conventional commercial AC is being considered. Bidirectional DC-DC converters(BDC) serves the purpose of stepping up or stepping down the voltage level between its input and output along with the capability of power flow in both the directions. BDC control the power flow between the dc bus and the low-voltage sources such as back-up batteries, fuel cells and super capacitors. The bidirectional dc-dc converter along with energy storage has become a promising option for many power related systems, including hybrid electric vehicle, fuel cell vehicle, renewable energy systems, uninterruptible power supplies, satellite and so forth [1]-[2], [3]. It not only

2. DESIGN OF BDC

Specification $V_{io} = 12V$ (Input voltage), $V_{hi} = 24V$ (Output voltage)

$$P_o = 100W, f = 10kHz, \frac{\Delta V_o}{V_o} \leq 10\%$$

Table 1: Design values of BDC

Sl. No	Specification	Design Value	
		Boost mode	Buck mode
1	Duty ratio (D)	0.5	0.5
2	Resistance (R)	5.76Ω	1.44 Ω
3	Inductance(L)	45μH	45μH
4	Capacitance(C)	86.805μF	138.88 μF
5	Full load current (I _o)	4.166 A	8.33 A

2.1 DESIGN OF COUPLED INDUCTOR

Specifications:

Input Voltage $V_i = 24V$, Output Voltage $V_o = 12V$ at $8.33A$, Switching Frequency $f_s = 10kHz$, Magnetizing current ripple $\Delta i_m = 20\% I_m$ (demagnetizing current = $12A$) Duty cycle $D = 0.5$, Turns ratio $N_s / N_p = 0.3$, Assume copper loss $P_{cu} = 1.5W$, Wire resistivity $\rho = 1.724 * 10^{-6} \Omega cm$, Core cross sectional area $A_c = 1.09 cm^2$, Winding fill factor $K_u = 0.3$, Core Maximum flux density $B_{max} = 0.25T$, Core window area $A_w = 0.256 cm^2$

Table -2: Design values of coupled inductor

Sl. No	Specifications	Design value
1	Magnetizing inductance (L_m)	250 μH
2	Winding current (I)	17.07 A
3	Primary number of turns (N_p)	13 Turns
4	Secondary number of turns (N_s)	4 Turns
5	Wire guage	19 AWG
6	Power loss density (ΔB)	0.04 W/cm ³
7	Core loss (P_{fe})	0.25 W

3. SIMULATION RESULTS

3.1 By fuzzy PI control

In Fig:2 proposed BDC buck mode line regulation is obtained by fuzzy PI control by varying input voltages to get output voltage constant. The simulation waveforms are in Fig 3, which gives the input voltage and output voltage waveforms. Fig 4 which gives the combination of PI and fuzzy PI output waveform of proposed buck mode for line regulation. In fuzzy PI control the output voltage settles faster than PI control.

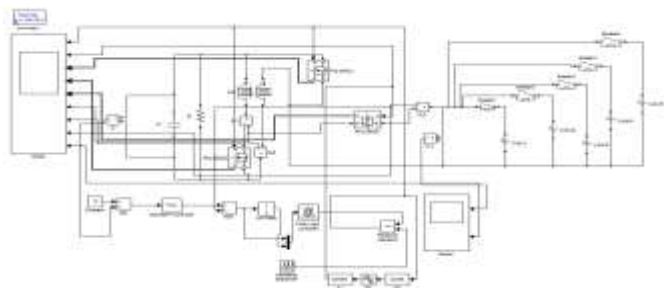

Fig - 2: Proposed BDC buck mode line regulation with fuzzy control circuit

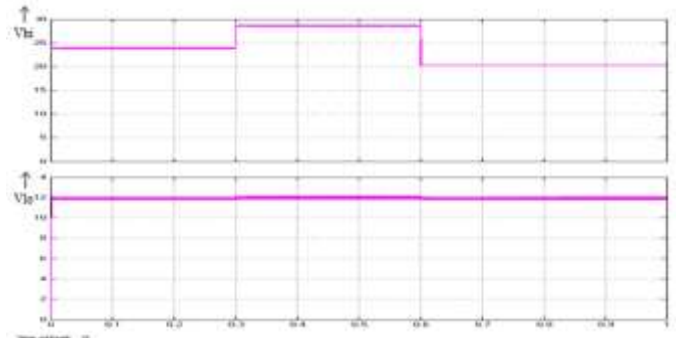

Fig - 3: BDC buck mode line regulation with fuzzy control waveform

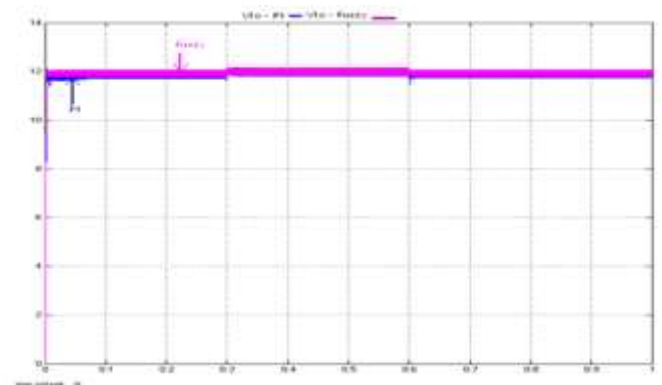

Fig - 4: Comparison of PI and fuzzy PI waveform in proposed BDC buck mode line regulation

4. HARDWARE IMPLEMENTATION

Figure- 5 shows the hardware implementation of proposed BDC using dsPIC30F4011/4012. Figure6.8 shows an output voltage waveform of 24V in boost mode operation when input of 12V supply is given. Figure - 6 shows an output voltage waveform of 12V in buck mode operation when input of 24V supply is given.



Fig - 5: BDC circuit using dsPIC

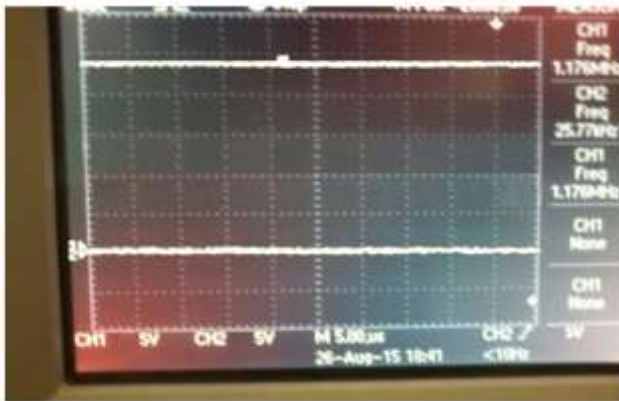

Fig – 6: Output Voltage waveform of Boost mode operation

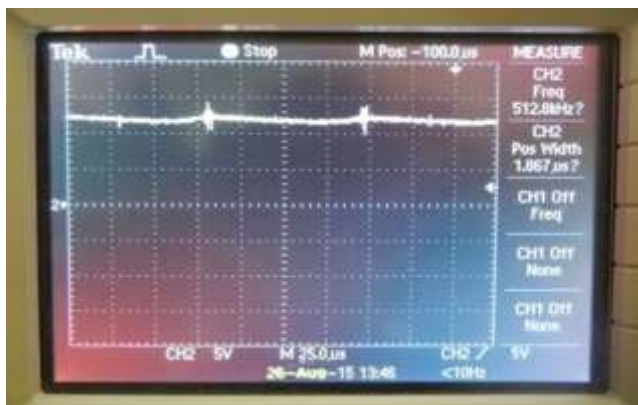

Fig – 7: Output Voltage waveform of Buck mode operation

CONCLUSION

The Analysis for conventional BDC and proposed BDC is done using state space modeling, designed the PI controller and simulation for conventional BDC and proposed BDC is simulated in open loop and closed loop (PI) control with input given as 12V and output obtained as 24V in boost mode and input given as 24V and output obtained as 12V in buck mode. In simulation for closed loop (PI and fuzzy PI) control, line regulation is obtained by varying input voltages and output voltage is obtained approximately constant as 24V in boost mode and 12V in buck mode operation. In simulation for closed loop (PI and fuzzy PI) control, load regulation is obtained by varying load current and output voltage is obtained approximately constant as 24V in boost mode and 12V in buck mode operation. Compared to fuzzy PI and PI control the rise time and settling time is reduced in fuzzy PI. Hardware Implementation for proposed BDC is done using dsPIC to generate pulses for open loop control in boost mode and buck mode operation. In hardware implementation of boost mode operation an input of 12V is supplied and output of 24V is obtained and in buck mode operation an input of 24V is supplied and output of 12V is obtained.

References:

- [1] H. Tao, J. L. Duarte, and M. A. M. Handrix, "Line-interactive UPS using a fuel cell as the primary source," *IEEE Trans. Ind. Electron.*, vol. 55, no. 8, pp. 3012–3021, Aug. 2008.
- [2] F. Shang and Y. Yan, "Novel forward-flyback hybrid bidirectional DC-DC converter," *IEEE Trans. Ind. Electron.*, vol. 56, no. 5, pp. 1578–1584, May 2009.
- [3] P. Das, S. A. Mousavi, and G. Moschopoulos, "Analysis and design of a nonisolated bidirectional ZVS-PWM DC-DC converter with coupled inductor," *IEEE Trans. Power Electron.*, vol. 25, no. 10, pp. 2630–2641, Oct. 2010.
- [10] T. Bhattacharya, V. S. Giri, K. Mathew, and L. Umanand, "Multiphase bidirectional flyback converter topology for hybrid electric vehicles," *IEEE Trans. Ind. Electron.*, vol. 56, no. 1, pp. 78–84, Jan. 2009.

BIOGRAPHIE



Mrs Anusree M
Assistant Professor
Rajiv Gandhi Institute of
Technology
Bengaluru – 560032.