

# Design and Construction Fill Control Camera using Raspberry Pi and Open CV for Pharmaceutical Blistering Machines

Alireza Ghasemlouy<sup>1</sup>, Tohid Karimian<sup>2</sup>

<sup>1</sup>Master, Dept. of Electronic Engineering, Seraj Higher Education, Tabriz, Iran

<sup>2</sup>Master, Dept. of Communication Engineering, Urmia Graduate Institute, Urmia, Iran

\*\*\*

**Abstract** - Today, with the advancement of technology, industrial automation and robots have replaced human forces. In the pharmaceutical industry, because of high sensitivity to prevent contamination and maintaining the optimal product quality, controllers should be used while packing. Considering the advantages of image processing systems, compared to older electromechanical systems (which have high maintenance costs), control cameras are used. These real time cameras should be capable of detecting the fullness of each blister, fracture, etc. In this paper, we have tried to control and evaluate the tablet blister by providing a functional and executive approach. Due to the continuous process of blistering machine, the speed of detection of being full or incomplete is very important. Furthermore similar cameras were very expensive and not comparable to the cost of construction of suggested camera. Some other features are: user friendly GUI, low error rate, uses the machine at maximum speed, And most importantly It's economical to build it because using Raspberry Pi, which itself is a minicomputer of credit card size and is of a very low price. The system is programmed using python programming language.

**Key Words:** Blistering Machine, Fill Control Camera, Raspberry Pi, Python, Open CV

## 1. INTRODUCTION

In the last few years a significant amount of research work has been done using Raspberry Pi and other Nano (smart) devices. Similar to fingerprint search system. Face recognition can assist law enforcement agencies in identifying suspects or finding missing person or access control system in highly secured places. Also home automation can be controlled via the internet using web services [1]. All mentioned cases use Raspberry Pi. In this paper a fill control camera is proposed based on Raspberry Pi, Python and Open CV which operates according to the user command received from the graphically user interface (GUI) [2]. After construction the device is installed on the Uhlmann UPS2 blistering machine and its performance was tested. The result was excellent and error free.

In this paper, first the problem has been defined, and then a cost-effective solution to that problem using Raspberry Pi has been proposed. Another problem is older

electromechanical fill controls. These controllers have a low accuracy and High Maintenance Costs.

The Raspberry Pi device was used to acquire an image stream from CSI camera. The device was used with the following specifications and configuration and software details are also given in Table 1. The Raspberry Pi has a Broadcom BCM2837 system on a chip which includes an ARM cortex-A53, 1.4GHz processor, video core IV GPU and an SD card slot. The GPU of the Raspberry Pi is capable of video playback using H.264 which can play Blu-ray quality videos at 40MBits/s. Open GL ES2 and Open CV libraries are used to access fast 3D cores. There are several ports present on the Raspberry Pi 3 Model B+ board including HDMI, 2x2 USB, Ethernet and several others.

**Table -1:** Raspberry Pi software specification

Name	Configuration
OS	NOOBS (Raspbian)
Programming Language	Python 3.7
Libraries	Threading, Tkinter, Numpy, Sys, Os, Time, RPL.GPIO
Imaging Libraries	PIL, Open CV

Raspbian is the default operating system of the Raspberry Pi and it provides the best support for device, in comparison with other operating systems. Furthermore, the community support for Raspbian is appreciable. Since Raspbian is built on the flavour of Debian, it naturally has all the features and compatibilities required for the project. Python 2.7 and 3.7 is already part of the Raspbian operating system and therefore a separate installation is not necessary. The reason that we chose Python 3.7 is because it has more resource community support available and it is fully compatible with Open CV3. The project requires some external Python libraries that need to be installed separately [3].

Open CV "open source PC vision library" is an open source picture preparing library made by Intel 8109 what's more, kept up by Willow carport accessible for C,

C++, what's more, Python. OpenCV is needs a compiler like DevC++, code squares, visual C++. This research utilizes C++ dialect furthermore, DevC++ compiler. In OpenCV there are four modules. Predominantly utilized are CV: primary OpenCV capacities, picture handling calculations, vision calculations and high GUI: GUI capacities, Image and Video I/O. Utilizing this OpenCV, we will stack pictures caught by camera. These pictures are in three configurations paired pictures, dark scale pictures and shaded pictures. The hued pictures contain R G B with pixel values containing 0-255. It has profundity of the picture with 8 bits and 3 channels. For stacking picture, utilizing OpenCV in python recommended [4].

## 2. THE PROPOSED SYSTEM

This camera preserves the quality and avoids custody of the Customer and maintaining the reliability of pharmaceutical companies with an exact and quick examination of the products in pharmaceutical industry.

The location of the camera on the blistering machine is shown in the figure 1:



Fig - 1: Location of camera on Uhlmann UPS2

This method is replaced with electromechanical method. The advantage of this method is mentioned below:

- 1- The ability of detecting fullness or emptiness of blister, broken tablets and different colors.
- 2- Performs faster setting for new products
- 3- Insignificant depreciation and less maintenance cost
- 4- There is no need to replacements while changing a part or changing the size of each product.

And the disadvantages are: 1. being expensive 2. Requires skilled operators

Fig. 1 indicates the location of PVC, heating station, forming station, feeder, fill control camera, sealing, foil roll, index and cutter.

The following process describes the function of the device the PVC roll is heated in the heating station (which is made of two discs with about 5mm distance) and then the heated PVC roll is imposed to a high air pressure in the forming part. Eventually the shape and the size of the roll are formed.

Later on, the created empty rolls are filled with pills by the feeder and also controlled by cameras, then in the sealing stage, foil and PVC's stick together and enter the cutting stage via index (index controls the timing of the process).

The system is based on Raspberry Pi and GUI to control system. The Tkinter library has been used to design the GUI. 6 buttons are used, that 3 buttons are used to start process, preview and stop, 2 buttons are used to reserve and 1 is used to exit. The GUI window in full screen mode and Operator can't access to any part of operating system and only system administrator can exit the program after entering the master password. The block diagram of proposed fill control system is shown in Fig2.

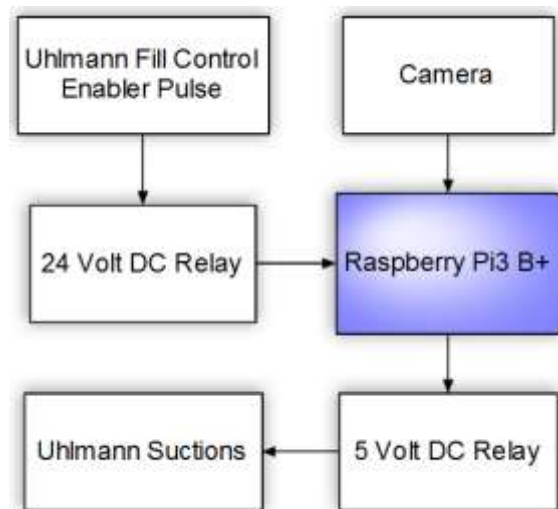

Fig - 2: Hardware configuration

## 3. PROPOSED PROGRAMMING OF FILL CONTROL SYSTEM

In fill control a camera is interfaced with Raspberry Pi via cable. A 24Vdc relay is also connected to the Raspberry Pi and it can only be stimulated through input pulse from blister machine when it's enabled, Raspberry Pi captures the image using software code written in Python and Open CV for blistering fill control.

The method used to detect the full or empty blister is to count the number of black pixels. In this way, if the number of black pixels is less than threshold value, it indicates that the blister is incorrect.

The flowchart of whole steps of image processing is shown in fig 3.

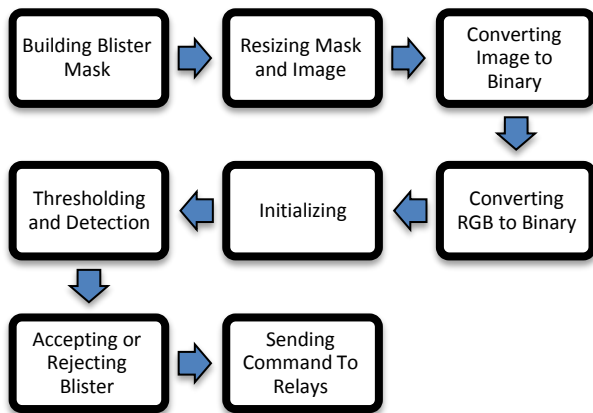

Fig - 3: Image processing steps

When operator presses start button, camera continuously captures video. Then resizes mask image and video resolution to defined size and puts mask and video together. This stage is important because the threshold value depends on image dimensions.

The next step is to convert image to binary. Converting RGB to binary decreases amount of data and boosts the speed of process. In thresholding level, the threshold value is calculated for the full blister and also for blister with an empty cell.

In Figure 4, steps 1 to 5 indicate these items.

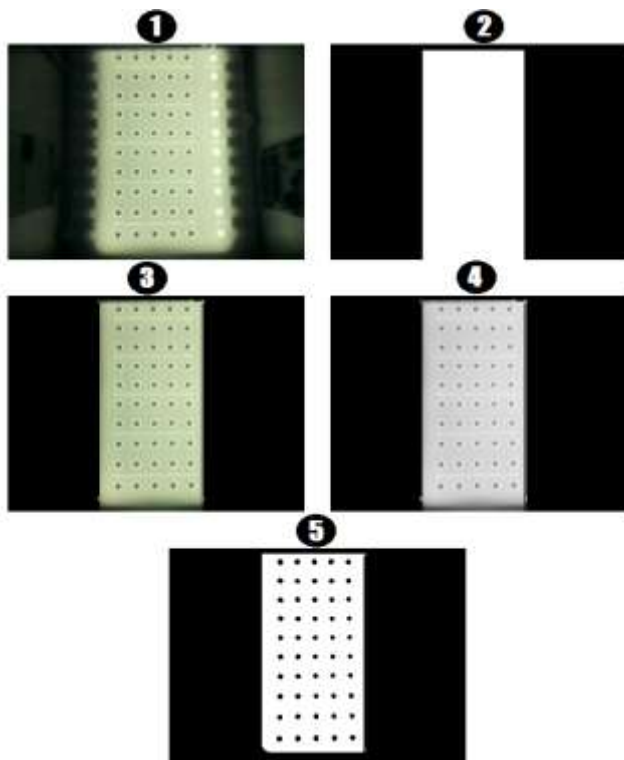

Fig - 4: Camera captured image processing steps

After initializing thresholding setting completely and detecting the blister controlled by the camera, in order to realize whether the blister is completely full or not, accept the blister row if the value is correct, otherwise reject the blister, usually notified with a warning message.

According to the solidity of tablets and the light which is reflected from the bottom, the color of tablets will not affect the processing.

When the Raspberry Pi commands to reject a blister, through GPIO Pin send pulse to stimulate the 5Vdc relays. When each relay is turned ON, the rejected row does not suction and falls down.

#### 4. CONCLUSIONS

Replacing control cameras and using image processing instead of old electromechanical systems is an important step for improving product quality and compliance with standards and quality assurance of products manufactured in the pharmaceutical industry. These cameras have a direct impact on increasing production and reducing maintenance cost and human errors with high speed, precision and user friendly interface. Designed system smaller than similar ones and price of manufacturing is much more convenient than other systems that are built in other ways.

After being constructed and installed on the blister machine, the camera successfully completed the test steps, that the error percentage was approximately zero.

#### REFERENCES

- [1] Xu, Z., et al., Raspberry Pi Based Intelligent Wireless Sensor Node for Localized Torrential Rain Monitoring. Journal of Sensors, 2016. 2016.
- [2] Chowdhury, N., S. Nooman, and S. Sarker, Access Control of Door and Home Security by Raspberry Pi through Internet. Int. J. Sci. Eng. Res, 2013. 4: p. 550-558.
- [3] Atick, J.J., P.A. Griffin, and A.N. Redlich, Continuous video monitoring using face recognition for access control. 2000, Google Patents.
- [4] P. Kalaivani and D. S. Vimala. "Human Action Recognition Using Background Subtraction Method." International Research Journal of Engineering and Technology (IRJET) 2.3 (2015): 1032-1035.
- [5] Koo, Yun Seo; Fathy, Aly; Kazemi, Robab; Liu, Quanhua; Phillips, Jeffery, (2014) "Development of a High SAR Conformal Antenna for Hyperthermia Tumors Treatment," Transaction on Antennas and Propagation, AP1401-0028.RI, 02-May.