

# HYBRID ENERGY FROM ARTIFICIAL NANOTREE

Dr. K. Uma devi<sup>1</sup>, K. Veilammal<sup>2</sup>, V. Gokilavani<sup>3</sup>, S. Keerthana<sup>4</sup>

<sup>1</sup>Professor/HOD of ELECTRICAL AND ELECTRONICS ENGINEERING, Sengunthar Engineering College, Tiruchengode, Tamilnadu, India

<sup>2,3,4</sup>Students of ELECTRICAL AND ELECTRONICS ENGINEERING, Sengunthar Engineering College, Tiruchengode, Tamilnadu, India

\*\*\*

**ABSTRACT:** - The world faces energy crises under the scarcity of reliable and efficient energy resources. This increasing in energy demand leads to the existing sources of fossil fuels and growing concerns regarding environmental pollution and other natural hazards push the mankind to explore new technologies for the production of electrical energy. So in order to generate the electrical energy in an ecofriendly manner we have to switch over to renewable resources. The paper presented here accentuates the working of a Nano tree using sun tracking system. In this concept wind energy and solar energy is used to generate the electricity with the help of nanoleaves. Several Nano leaves are placed in the form of tree is called solar botanic tree. Nanoleaves consist of photovoltaic cell, thermovoltic cell, piezoelectric cell. The power generation from the Nano leaf is environmental friendly and this can be installed in different location. The main objective of this paper is to track maximum amount of sunlight. Along with this it will also generate wind and thermal energy. This may called as hybrid energy. To face the increasing energy demand of the people and saving of the land this solution is useful one. This can provide electricity without power cut problems. The proposed system consist of Nano leaves that is the combination of Nano photovoltaic, Nanothermovoltic, Nano-piezoelectric cells absorbing light, heat and kinetic energy into eco-friendly energy. Instead of this system we can improve the system by using pervoskite materials.

**KEY WORDS:** Bio-mimicry, Thermal Voltaic Cell, Photo Voltaic Cell, Piezo Electric Cell, Pervoskite Solar Cell, Hybrid Energy.

## 1. INTRODUCTION:

Nano leaf technology is the ingenious method of hybrid energy combining the conversion of light, heat and wind power [1]. The leaves are distributed through artificial trees and plants when operating at optimum efficiency can supply household with electricity. There are mainly two important reasons for which we should go for energy harvesting trees. Firstly this energy harvesting trees are eco- friendly in nature and neat form of energy. Secondly these solar trees could offer continuous plug-in stations for the electric vehicles and hybrids of the near and distant future [4]. It is the best option of energy

generation because it requires very less and as compared to the classical PV system. A Nano tree is a decorative means of producing electrical energy from the solar, wind and thermal energy. It uses multiple numbers of Nano leaves which are arranged in a tree like structure in which leaves are arranged in a tree like structure in different angles in order to capture maximum solar and wind energy from all directions. From this tree we can able to track maximum amount of sunlight and increase the efficiency. In future this makes use of renewable resources in millions of years.

## 2. METHODOLOGY:

Solar power keeps the surroundings disinfected and healthier. Photovoltaic cells that strap the solar power are an charming option for grab light and generate electric power. The Nano leaves have been specially designed to initiate the natural process of photosynthesis. The Nano tree is a combine of high Tec material brought together in a leaf design to convert [5] all 3 energy sources light, heat and wind into electricity, our trees are a quantum sources of power and excellent electricity provider. The artificial trees will every copy the natural recycling process of carbon -dioxide to oxygen conversion. It is only recently that Nano-leaves technology started to stride to even more advanced levels. It can how harvest thermal and wind energy in addition to solar.

## 3. BIOMIMICRY:

Biomimicry is a modern technology that uses Nano leaves attached to artificial trees and plants to confiscate solar energy. Bio-mimicry and Nano leaf technology are intrinsic to each other. The Nano leaves the Z-scheme of natural process of photosynthesis. The mechanism by which, typical plants absorb the light emitted by the sun and CO<sub>2</sub> in the atmosphere. The artificial trees do even as well. Moreover, the leaves fixed on artificial trees are also able to collect energy derived through movement of the wind; known is as well converted into electrical energy derived through movement of the wind, known as kinetic energy, which is as well converted into electrical energy. It is a developing science pursuit to solve human difficulties

by accustoming to and implementing nature systems into human technology.

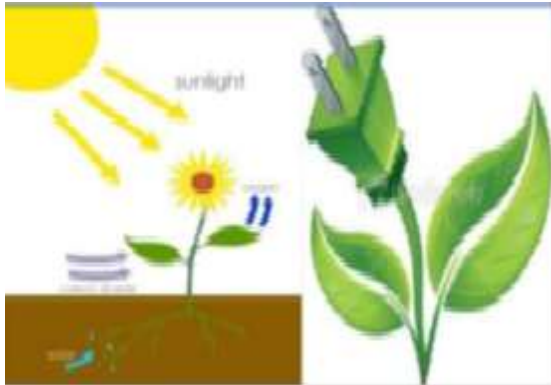

Fig1: Artificial Photosynthesis

4. MODULATORS IN NANOLEAF:

- Photovoltaic cell
- Thermovoltaic cell
- Piezoelectric cell

5. HYBRID ENERGY:

Hybrid energy is nothing but the combination of two or more sources. In this concept three types of energies are combined such as thermal energy, light energy and kinetic energy.

5.1 Thermal energy:

The thermal energy which has been absorbed by the conversion of solar heat into electricity by means of Nano-Thermovoltaic cells.

5.2 Light energy:

There are also tiny photovoltaic cells sandwiched on the nanoleaves. These tiny photovoltaic cells capture the light rays emitted by the sun. This light is then converted into electricity.

5.3 Kinetic energy:

The kinetic energy harnessed through the movement of leaves. The wind from atmosphere produces motion in stems and branches. This motion is collected by means of piezoelectric cells. This converts the kinetic energy into electricity.

6. SYSTEM LAYOUT:

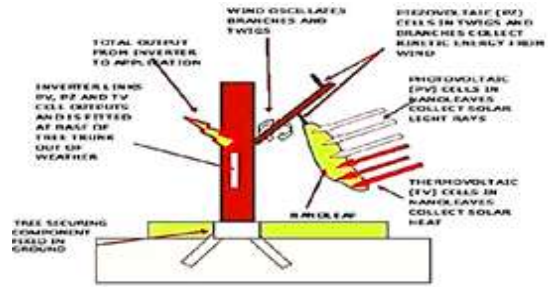

Fig2: System model

The general layout of system shows the mechanism of electricity generation when sunlight falls on the Nano-leaf, the photons are absorbed into it; this energy causes the electrons to become free. The electrons move towards the bottom of the Nano leaf and exit through the connecting nanowires working as trunk. This flow of electrons is referred to as low electricity.

In the similar way when the environment is hot, the thermos voltaic layer produces the electrical energy. Whenever the leaf is getting stress due to wind or rain, then piezo electric layer produces the electricity. If the other type of light falls on the Nano leaf, then the photovoltaic produces the electricity. The output of each layer is connected to the single storing device at the bottom of tree. The photovoltaic, piezo voltaic and thermovoltaic energy harvesters are connected to individual junction boxes from where they are amalgamated and fed collectively into an inverter. This converts the electricity from DC into Ac electrical power now is suitable for domestic and industrial uses. Artificial energy trees can be used for both domestic and even industrial purposes. More, intricate is that, artificial trees can be constructed at various places like parks, deserts, office premises and industries etc.

7. LEAF STRUCTURE:

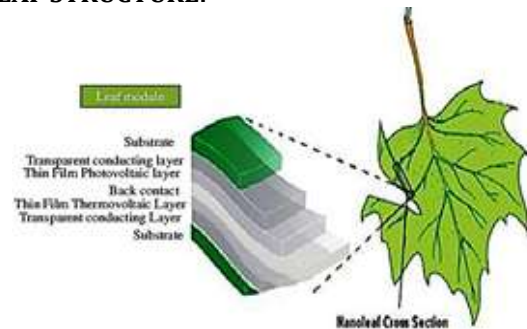
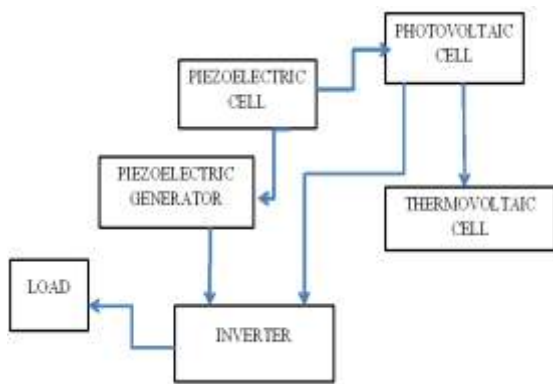

Fig3: Leaf structure

First of all we are creating two transparent conducting layers of silica which act as the outer body of the leaf. After this we are placing one solar cell in between these two layers which is used to convert the solar energy into electrical energy then we are placing the piezo voltaic cell, Thermal voltaic cell and photo voltaic cell. These all the cells are interconnected to the highly conducted metal film to complete the circuit for the flow of electrons and photons. Now these leaves are connected to the twigs of the artificial tree [3]. Then these small twigs are connected to the stem of the tree with the means of the piezoelectric crystal to convert the stress of the twigs also into electrical energy. The electrical energy from the all leaves and twigs is stored at the bottom of the tree by using the storage device.

**8. BLOCK DIAGRAM:**



**Fig4.Block diagram**

**9. SIMULATION RESULTS:**

**Frequency:**



**Inverter 1 voltage:**

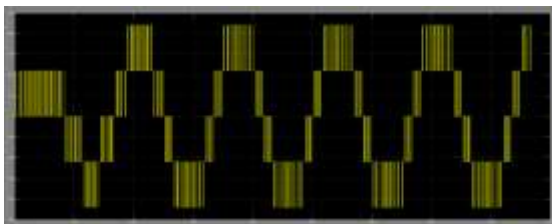

**Inverter 2 voltage:**

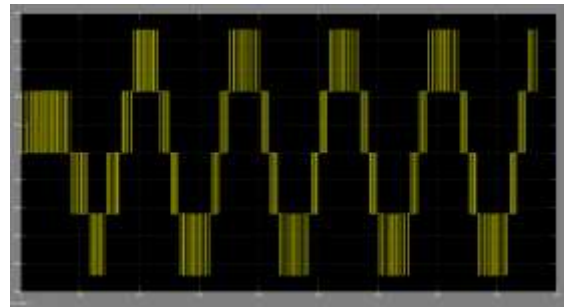

**Combined output:**

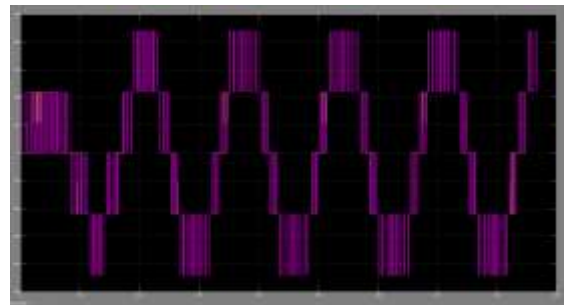

**Grid power:**

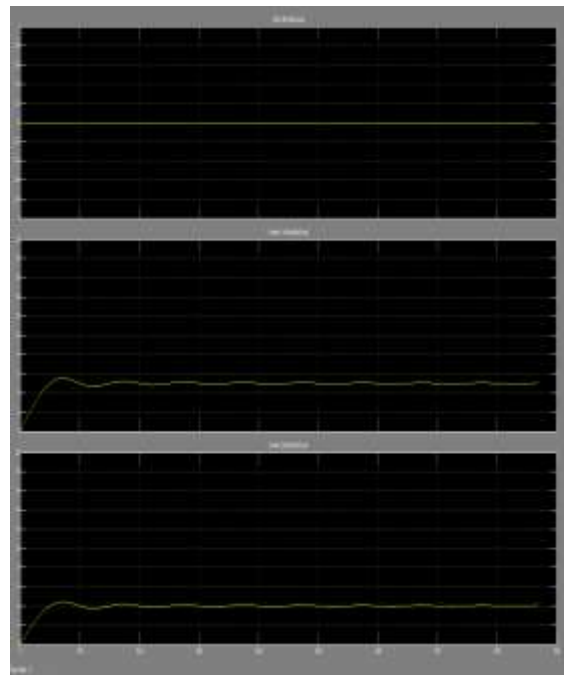

These figures represent the approximate output of the tree further we may improve this energy by using pervoskite solar cell instead of silicon solar cell.

## 10. ALTERNATE SOLAR CELL:

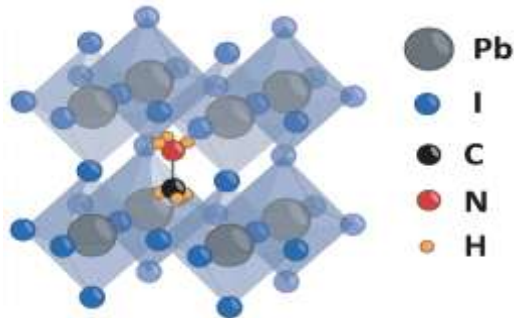

Fig: pervoskite solar cell

A perovskite solar cell is a type of solar cell which includes a perovskite structured compound most commonly a hybrid organic-inorganic lead or tin halide-based material, as the light-harvesting active layer. Perovskite materials such as methylammonium lead halides are cheap to produce and relatively simple to manufacture. Put simply, perovskite solar cells aim to increase the efficiency and lower the cost of solar energy. They are also predicted to play a role in next-gen electric vehicle batteries, sensors, lasers and much more.

## 11. APPLICATION AREAS OF NANOTREE:

The nanotechnology plays a vital role in major application areas. This Nano tree has also been used in various places like,

- Deserts
- Office car parks
- Recreational grounds
- Industrial units
- Charging purposes in electric vehicles

## 12. CONCLUSION:

As the solar botanic trees are a non-conventional source, we have many advantages of producing electricity compared to the other resources. Green energy is the need of the hours and it is our responsibility to ensure a safer planet for the future generation. Using such technology power-producing solar products could be applied to just about any surface downtown.

## REFERENCES:

[1]. Ashwini's, Shekhanabi B Chalageri, Mohammed Sameer H Yadahalli international journal of advanced research in science, engineering and technology **Energy Scavenging Artificial Tree**, Vol-4, issue 5, May 2017. ISSN: 2350-0328.

[2]. Vikas Kumar Tiwari, Amulya Niraj Khalkho and Gyan Prakash Ranjan International Journal of Engineering Sciences and Management **Nano Tree with Sun Tracking Nano Leaves Future Energy Aspects**-Tiwari (January 2017) ISSN 2277-5528

[3]. Mohid Nissar, Dr. Aziz Ahmad IJTSAD. UGC Approved International Open Access Journal –**Solar Power Tree-An Artistic Design**. Volume-1 Issue-5 ISSN: 2456.

[4]. Vimal Kumar, T. Dhamodharan, R. Rajagopal South Asian Journal of Engineering and Technology. **Nano Tree-The Latest Renewable Energy Resource**. Volume-2, Nov 22 (2016) 106-111 ISSN NO: 2454-9614.

[5]. Dr. K. Uma devi and Mr. R. Karthikeyan, "Design and analysis of FPGA based high-Resolution Digital Pulse With Modulators Technique for DC-DC Converters", International Journal of Advance Research and Innovative Ideas in Education, Vol. 3, Issue 6, 2017, pp. 1526-1533.