

SPEAKING SYSTEM TO MUTE PEOPLE USING HAND GESTURES

S.K. Imam Basha¹, S.Ramasubba Reddy²

^{1,2}Assistant Professor, Dept of ECE, Chaitanya Bharathi Institute of Technology, Proddatur, A.P, India.

Abstract - Mute people can't speak and normal people don't know the sign language which is used for inter-communication between mute people. This system will be useful to solve this problem. Gestures are in line with people's habits of communication, so many researchers have done a lot of work in gesture recognition based on vision based approach. In this paper, hand gestures also known as sign language will be converted into voice for mute people. Image processing is used for hand gesture recognition in this

system. Using camera to get images of hand, and then pre-process those images by color splitting, morphological processing and feature extraction. At last, the template matching is used to realize the hand gesture recognition. The recognized image is processed by the hardware and converted to voice.

Keywords: Gesture Recognition, Hand Tracking, ARM Processor, SD Card.

I. INTRODUCTION

With the massive influx of computers in society, human computer interaction, or HCI, has become an increasingly important part of daily lives. Current user interaction devices with keyboard, mouse and pen are not sufficient for physically challenged people and Virtual Environment (VE) which induce many new types of representation and interaction. Gesture, speech, and touch inputs are few possible methods of meeting such user's need to solve this problem. . To achieve nature human-computer interaction for VE application and the disabled people, the human hand could be an input device. Numerous approaches have been proposed for enabling hand gesture recognition. A common taxonomy is based on whether extra devices are required for raw data collecting. In this method, they are categorized into[1].

with the system. In vision based hand gesture recognition system , the movement of the hand is recorded by video camera(s).Vision based technology deals with some image characteristics such as texture and color for acquiring data needed for gesture analyze.

1.2. A Common Gesture Recognition System

Following is the fig.1 showing a gesture recognition system using image processing.

- ☑ Data glove based hand gesture recognition,
- ☑ Vision based hand gesture recognition.

For digitizing hand and finger motions into multi-parametric data, data-glove based methods use sensors. The extra sensors make it easy to collect hand configuration and movement. However, the extra devices are quite expensive and bring much cumbersome experience to the users. In contrast, the Vision Based methods require only a camera, thus realizing a natural interaction between humans and computers without the use of any extra devices.

1.1 Vision Based Hand Gesture Recognition

In vision based hand gesture recognition system, technology uses a bare hand to extract data for recognition. With the help of this technology user can directly interact

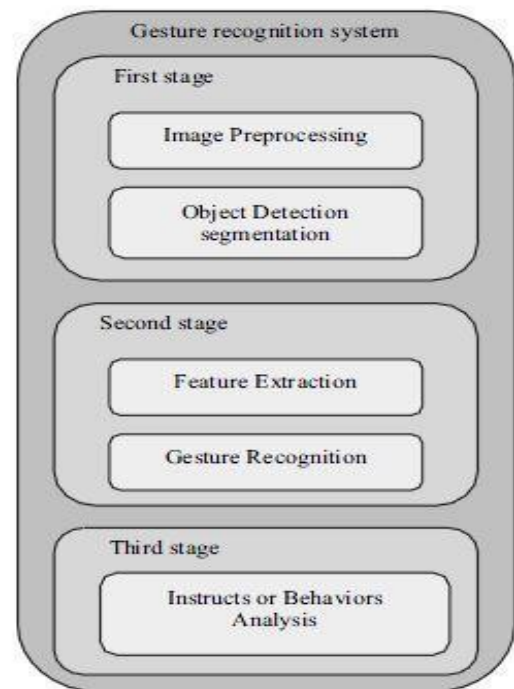

Fig.1. Common Gesture recognition system.

Most gesture recognition methods usually contain three major stages[2]. The first stage is the object detection. The target of this stage is to detect hand objects in the digital images or videos. Many environment and image problems are needed to solve at this stage to ensure that the hand contours or regions can be extracted precisely to enhance the recognition accuracy. Common image problems contain unstable brightness, noise, poor resolution and contrast. The better environment and camera devices can effectively improve these problems. However, it is hard to control when the gesture recognition system is working in the real environment or is become a product. Hence, the image processing method is a better solution to solve these image problems to construct an adaptive and robust gesture recognition system. The second stage is object recognition. The detected hand objects are recognized to identify the gestures. At this stage, differentiated features and effective classifiers selection are a major issue in most researches. The third stage is to analyze sequential gestures to identify users' instructs or behaviors.

2. THE DESIGN OF SYSTEM STRUCTURE

Our aim is to implement a hand gesture recognition system for mute people who communicate using sign language. The hand gesture will be converted to voice as defined by the person. The system will act as a communicator for the mute person. The system is divided in two modules- Image processing module for hand gesture recognition as shown in Fig.2. ARM processing module for voice and text conversion.

2.1 Image Processing Module For Hand Gesture Recognition

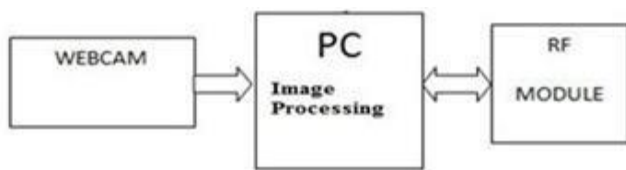

Fig.2. Image processing module.

In this the image of the hand is captured using webcam and processed using Matlab software for gesture recognition. Flow chart of hand gesture recognition system shown in Fig.3.

Image Acquisition And Preprocessing: The image is first acquired and preprocessed to remove noise from the image and to smooth the image[3].

Gray scale conversion: After smoothening the image, grayscale conversion is done to perform threshold on the image. Each pixel in an RGB image is made of three planes which are red, green and blue planes. In a 24-bit pixel, each 8 bit represents one plane which carries the R, G, B value in the pixels. After gray scale conversion, the pixel value converts to 8-bit value and carries only the intensity information.

Thresholding: After gray scale conversion, thresholding is performed. Thresholding is a technique where all pixels below some threshold value are turned to white and all pixels above thresholding are turned to black. It is performed to separate the foreground from the background to detect the objects.

Feature Extraction: After thresholding the shape of the object is detected using edge detection algorithm[3]. Shape is an important visual feature and it is one of the primitive features for image content description. Shape descriptors can be divided into two main categories: region based and contour-based methods. Region-based methods use the whole area of an object for shape description while contour-based methods use only the information present in the contour of an object. Canny edge detector is used for edge detection and feature extraction.

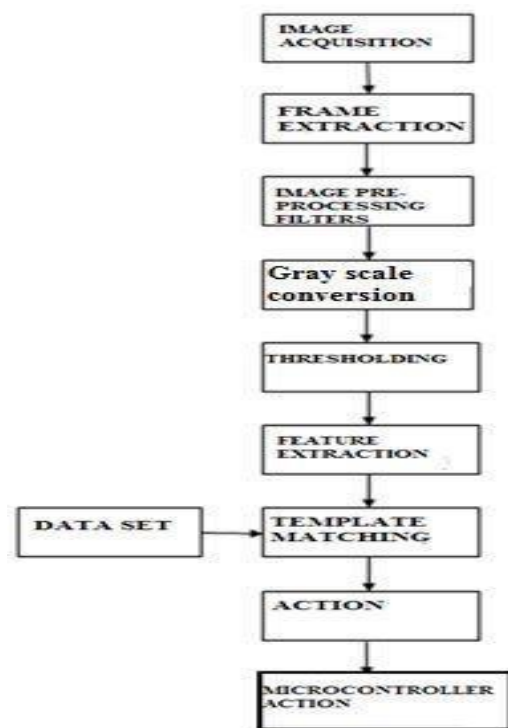

Fig.3. Flowchart of hand gesture recognition system.

Gesture Recognition: Template matching is used for gesture recognition i.e the image is compared with a dataset of images stored in the database and the gesture is recognized[3].

2.2. Communicating the Recognized Gesture to ARM Module

Once the gesture is recognized it is sent to the ARM module in the form of a unique code. Unique is of the form #11, #12, #13 etc for every gesture. For every gesture there is a unique code which is defined for a particular gesture. There is a dataset of handgesture, voice file for that gesture and the unique code of the gesture. The unique code when received by the ARM module is scanned and the voice file for that code is played from the SDCard. RF transmitter and receiver is used to send the unique code from the image processing module to ARM processing module.

2.3. ARM Processing Module – ARM Processor

The data coming from the gesture recognition module is received by the ARM processor through RF module as shown in Fig.4. The microcontroller will process the data received. Data is received in the form of a unique code. There is a database of voice messages which is stored in the SPI memory in the form of .wav files. SPI memory is basically a SDCard which is used as a memory and will be required to store the required database. For every unique code received there is a .wav file which will be played by the processor after scanning the database stored in the memory. SD card is interfaced with the system using a protocol called SPI protocol. For every gesture there is a unique code defined in the system database.

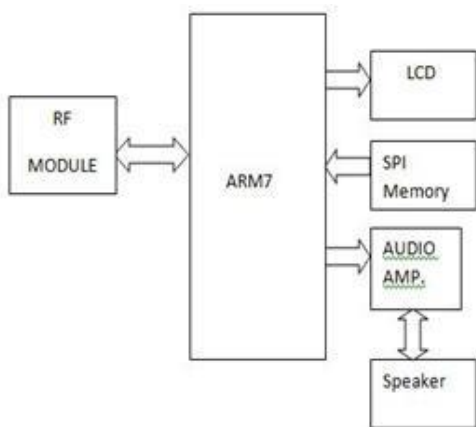

Fig.4. Block diagram of ARM processing module.

3. HARDWARE DESIGN

3.1 Microcontroller LPC2138

The microcontroller which is used is LPC 2138. The LPC2131/32/34/36/38 microcontrollers are based on a 16/32-bit ARM7TDMI-S CPU with real-time emulation and embedded trace support, that combine the microcontroller with 32 kB, 64 kB, 128 kB, 256 kB and 512 kB of embedded high-speed flash memory. A 128-bit wide memory interface and a unique accelerator architecture enable 32-bit code execution at maximum clock rate. For critical code size applications, the alternative 16-bit Thumb mode reduces code by more than 30 % with minimal performance penalty. Due to their tiny size and low power consumption, these microcontrollers are ideal for applications where miniaturization is a key requirement, such as access control and point-of-sale. Smart Card interface - The smart card is interfaced with the ARM using the SPI interface pins available on the ARM processor. SPI communication is based on MASTER, SLAVE concept. One of the communicating device is master and other is slave.

4. SOFTWARE DESIGN

The ARM processing module keeps checking for the code received on the serial port and plays the file from the SDCard for that particular value received from the image processing module as shown in Fig.5. If a file is currently being played it waits for some defined time and scans the SDCard again to play the file.

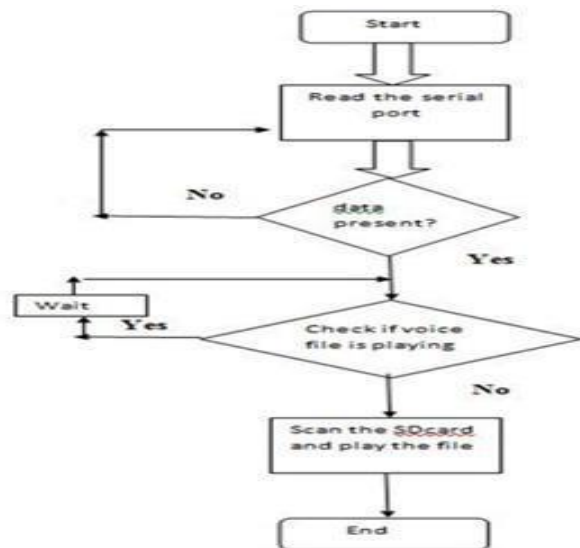

Fig.5. Flowchart of software in ARM module.

5. RESULTS OF EXPERIMENT

In order to check if the hardware is working as per the requirement, an experimental setup is done. In this, instead of sending the code from image processing module, dock light software is used to send code to the hardware. The software is running on a Computer, whose serial port is connected to the RS232 interface of the hardware board. When the code is sent like #11, #12, #13 etc corresponding voice file is getting played via the speaker.

6. CONCLUSION

The hand gesture regarded as the input of computer command has caused extensive research with the appearance of virtual reality. This system proposed a method to recognize multifarious static hand gesture. In this system, the preprocessing for the captured video image is done followed by feature extraction and classification. Gesture recognition is based on template matching. Hardware is developed which recognizes the hand gestures and converts it in voice. Presented study describes the way that gestures can be transformed into the group of computer interpreted symbols which can further processed. In this study, it is possible to convert gesture to voice, but in the same way a wide variety of different devices can be controlled as well.

7. REFERENCES

- 1) S. Mitra, and T. Acharya, 2007." Gesture Recognition: A Survey." IEEE Transactions on systems, Man and Cybernetics, Part C: Applications and reviews, vol. 37 (3), pp. 311-324,2007.
- 2) Ching-Hao Lai, "A Fast Gesture Recognition Scheme for Real-Time Human-Machine Interaction Systems", IEEE 2011 Conference on Technologies and Applications of Artificial Intelligence.
- 3) Yongjing Liu, Yixing Yang, Lu Wang, Jiapeng Xu, "Image Processing and Recognition of Multiple Static Hand Gestures for Human-Computer Interaction", IEEE 2013 Seventh International Conference on Image and Graphics.
- 4) Archana S. Ghotkar, Rucha Khatal , Sanjana Khupase," Hand Gesture Recognition for Indian Sign Language" , IEEE 2012 International Conference on Computer Communication and Informatics (ICCCI -2012).
- 5) P. Subha Rajam, Dr. G. Balakrishnan, "Real Time Indian Sign Language Recognition System to aid Deaf-dumb People", 2011 IEEE.
- 6) Wang Jingqiu1, Zhang Ting1,2"An ARM-Based Embedded Gesture Recognition System Using a Data Glove" ,IEEE Transactions 2014
- 7) Harshith.C1, Karthik.R.Shastry2, Manoj Ravindran3, M.V.V.N.S Srikanth4, Naveen Lakshmikanth,"Survey on various gesture recognition techniques for interfacing machines based on Ambient intelligence (IJCSSES) Vol.1, No.2, November 2010.

AUTHORS



S. K. Imam Basha, received his Master degree from J.N.T.University, Anantapur. He is presently working as an Assistant Professor in the Department of ECE, CBIT, Proddatur



S. Ramasubba Reddy received his Master degree from S.K. University, Anantapur. He is presently working as an Associate Professor in the Department of ECE, CBIT, Proddatur.