

# Stress and Fatigue analysis of Weldment of Rectangular Column Structure

Mahesh Gowda Patil<sup>1</sup>, Dr. B Ravindra<sup>2</sup>, H S Manjunath<sup>3</sup>

<sup>1</sup>M.Tech Scholar, Mechanical Engineering, Dr. Ambedkar Institute of Technology, Bengaluru

<sup>2</sup>Professor and Head of the Department, Mechanical Engineering, Dr. Ambedkar Institute of Technology, Bengaluru

<sup>3</sup>Assistant Professor, Mechanical Engineering, Dr. Ambedkar Institute of Technology, Bengaluru

\*\*\*

**Abstract** - Welding is one of the most important methods of joining of material. During welding numerous problems arise due to various conditions. These problems have to be rectified and solved for proper analyzing of the result. The method proposed here enables stress distribution and the stress concentration in the welded region by finite element technique. Low cycle fatigue analysis is done in order to find the required result. The procedure followed here is to find the maximum stresses acting on the weldment of rectangular column structure. This is done by creating model in solid edge and discretizing it in the abaqus by applying the loads and boundary conditions and linear analysis is performed. By performing this, maximum stresses acting on the welded structure is found. The stresses obtained from finite element analysis and the concentration factors are used for determining peak stress in stress distribution. These peak stresses obtained are used for finding the fatigue life of the welded column structure.

**Key Words:** Welding, S355 steel, Stress analysis, Fatigue, Finite element analysis

## 1. INTRODUCTION

Welding is a technique usually used for joining materials, generally metals by application of heat. The fatigue failure of welded joint is a major issue in any of the structure built. There may be catastrophic effects of these failures, if the problems are unattended. The major factor influencing the fatigue failure is the stress concentration and the effect of residual stress after the welding. There are different situations in which depending on the loading pattern weld may experience high cycle fatigue failure or low cycle fatigue failure.

Fatigue of materials is a complex phenomenon. Material homogeneity is disturbed by weld metal itself and also by the change of the crystalline structure in the (HAZ). Welding, distortions and residual stresses due to these stresses also make the stress state in the welded specimen much more different than a similar un-welded specimen. Furthermore, an 'ideal' weld can rarely be found in reality. Weld defects such as cavities, inclusions, undercuts, pores, etc. may occur. The welded and non-welded roots differ widely from the theoretical shape.

Therefore, the fatigue failure in welded structures usually forms at welds (or areas affected by weld) rather than in the

base metal. The dramatic decrease of fatigue strength of the welded component compared to the plain specimen and even specimen with a hole. It is noticeable that this decrease is resulted by adding the material to the component and not decreasing the cross sectional area of the component. This is in contrast to the general rule for statically loaded structures, in which adding the material to the cross section does not cause a decrease in the strength of the structure. Here an attempt is made to understand the method in which these failures can be predicted with greater accuracy using Low cycle fatigue failure in a structural column welding subjected to cyclic bending loads.

## 2. METHODOLOGY

The assessment of the long column support structure subjected to cyclical bending load due to harsh weather conditions of snow and wind. The stress distribution is studied and fatigue life is calculated. Load conditions for all the tests are as mandated as per recommended standards.

### 2.1 Stress analysis

Stress analysis of weldment of rectangular column structure is carried out using ABAQUS software. Initially the component is meshed in ABAQUS. ABAQUS is the solver. Stress analysis is performed to determine the maximum stresses induced in the Weldment of column structure to identify maximum compression in the structure. Weldment of column structure with maximum compression loads are considered further for fatigue analysis.

### 2.2 Fatigue analysis

Fatigue analysis is done after completion of static analysis in order to determine the maximum crack length in the material, due to application of stresses on the welding portion of the material. Low cycle fatigue failure analysis in a structural column welding is analyzed here. Structure after stress analysis is then imported to FE SAFE solver, FE SAFE correctly predicts the failure location due to different loading conditions.

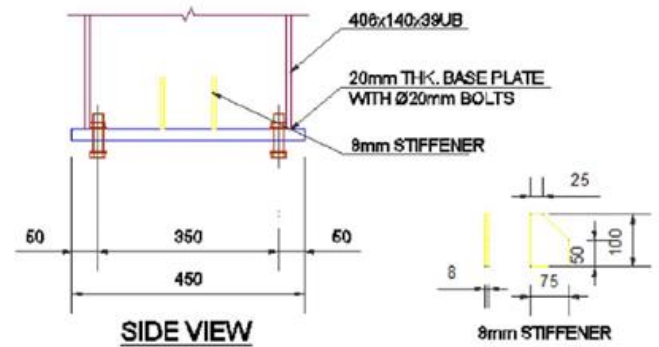
### 2.3 Material Properties

The material used for the study is S355 as this steel is the material with the existing future. The advantages of this are described together with recent developments which have

enhanced them, and improvements in manufacture, enhanced range of properties, improvements in fabrication, adaptability and consistent quality. The strength-to-volume ratio, the wide range of possible applications, availability, reliability of the material corrosion resistance and the ability to give shape to structures are some of the reasons to choosing of this material.

**Table-1:** Material properties

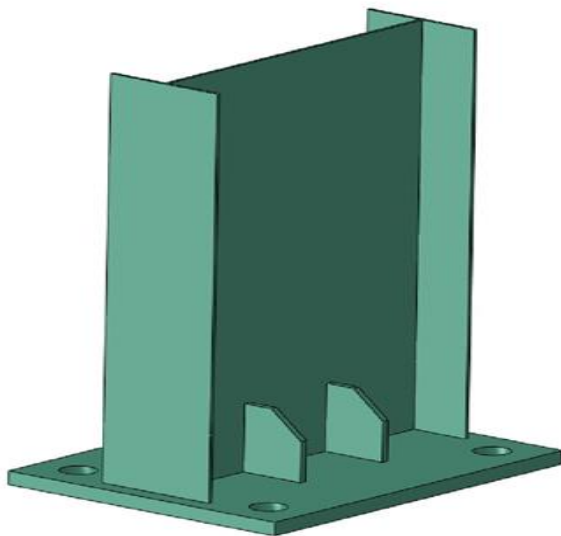
Property	Unit	Value
Density	kg/m <sup>3</sup>	7805
Young's modulus	GPa	205
Poisson's ratio	-	0.3
Tensile yield strength	MPa	415
Ultimate yield strength	MPa	520



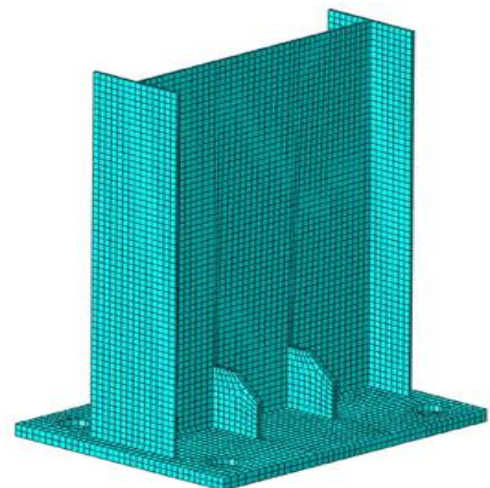
**Fig-3:** Side view

Geometrical rectangular column was modeled in solid works. It is a modeler which utilizes a parametric feature-based approach to create model and assemblies. Constraints are referred as parameters whose values determine the shape or geometry of the model or assembly. Parameters can be either numeric or geometric.

### 2.4 Geometric modeling

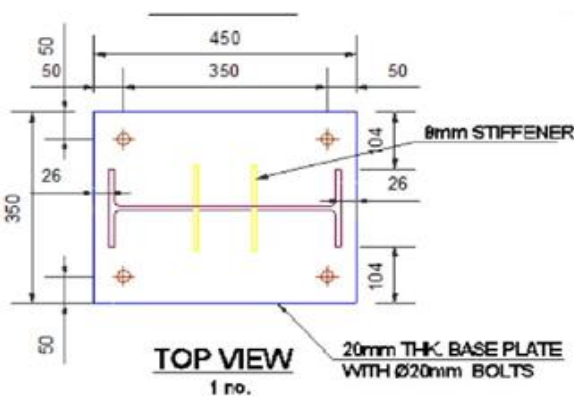


**Fig -1:** Geometric model

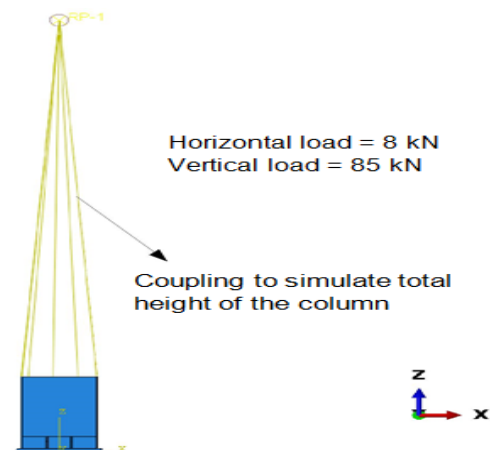


**Fig -4:** FE Meshed model

### 2.5 Loading conditions



**Fig -2:** Top view



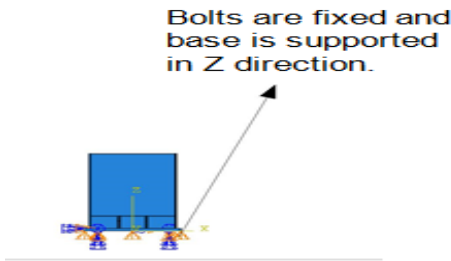


Fig -5: loading conditions

Loading conditions or loads are forces, acceleration or deformations applied to a structure or its components. Loads are applied on the above structure of 85KN vertically and 8KN horizontally and the bottom of column are fixed in Z direction.

### 3. RESULTS

#### 3.1 Stress analysis results

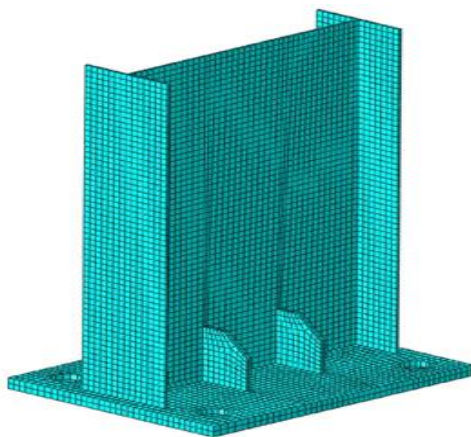


Fig -6: Meshing without weld volume

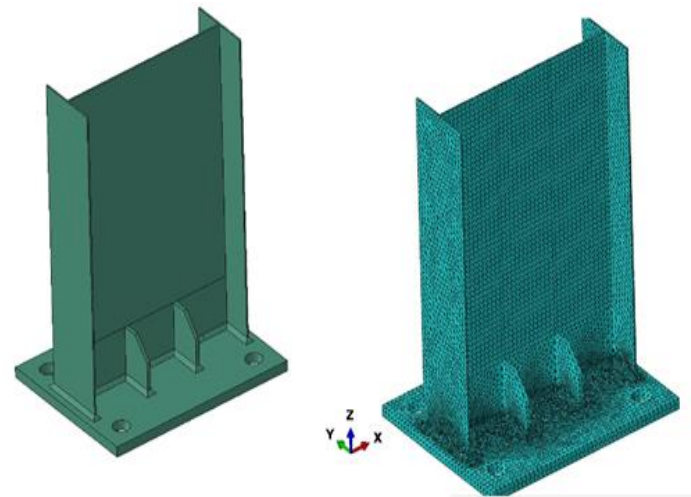


Fig -9: Meshing with weld volume

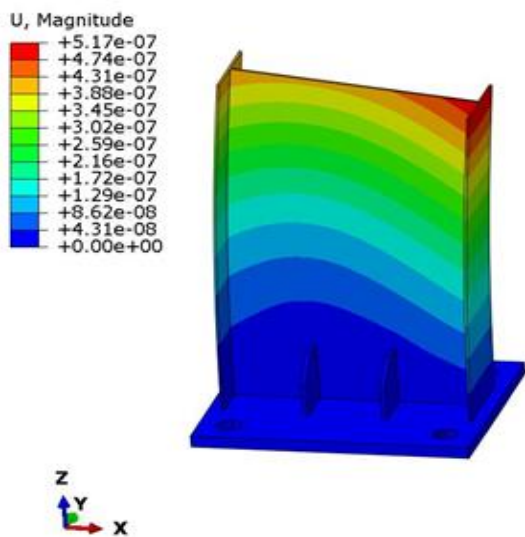


Fig -7: Displacement plot without weld

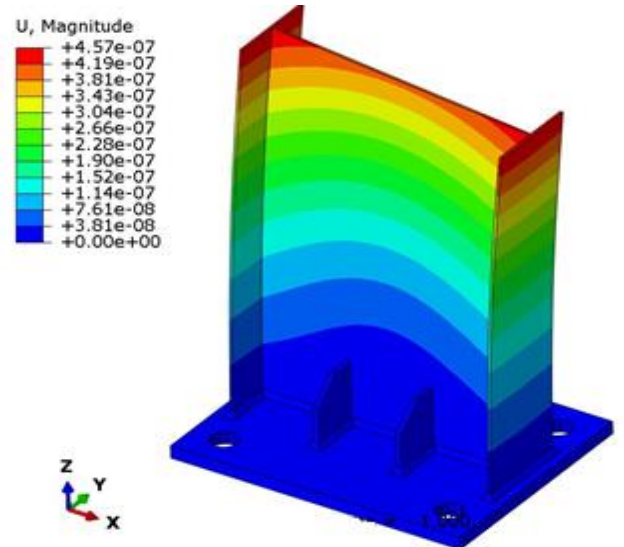


Fig -10: Displacement plot with weld

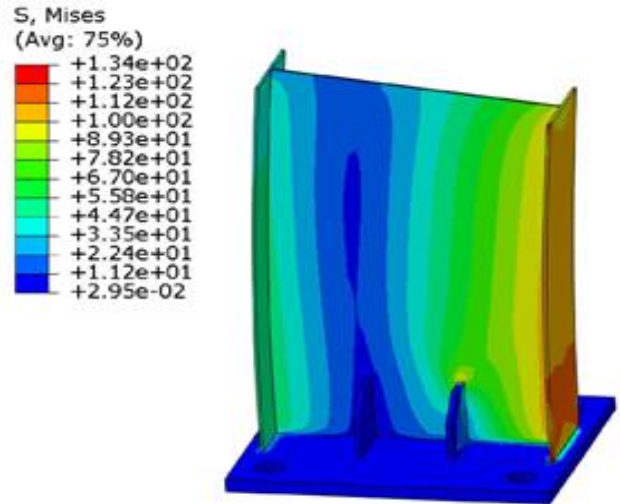


Fig -8: Elemental stress analysis without weld

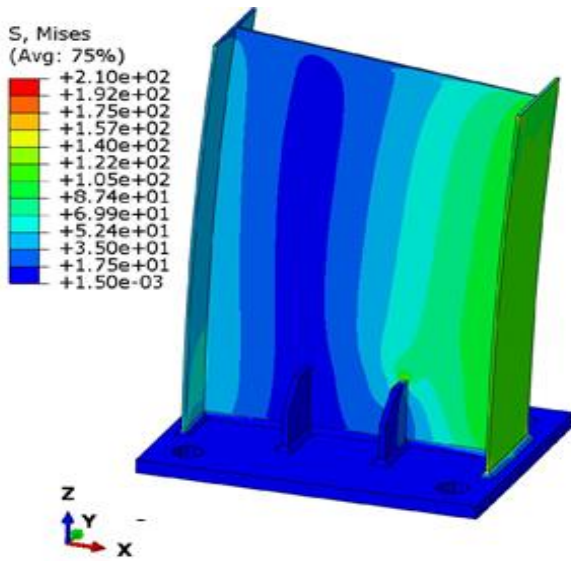


Fig -11: Elemental stress analysis with weld

By meshing the model in abaqus we come to know the total stresses acting on the welding surface. So total no of nodes and elements in the material are 15162 and 8388. Type of element used for meshing is Linear hexahedral element of type C3D8R. The maximum stresses without weld volume were found to be 134Mpa and the maximum stresses with weld volume were found to be 210Mpa.

### 3.2 Mesh convergence

Before going into the fatigue estimation, we need to check for the fairly accurate stress at the tension side of the beam root. So the mesh convergence study is performed in order to obtain a fairly accurate stress at the welded root of the beam.

Table-2.: Mesh convergence

Case	Max Principal (tensile stress)	Min Principal (Compressive stress)	Global element size	No of elements
1	101.4	205.4	4	421802
2	85.8	185.3	6	138442
3	83.1	206.3	8	99647
4	81.8	207.7	10	65632

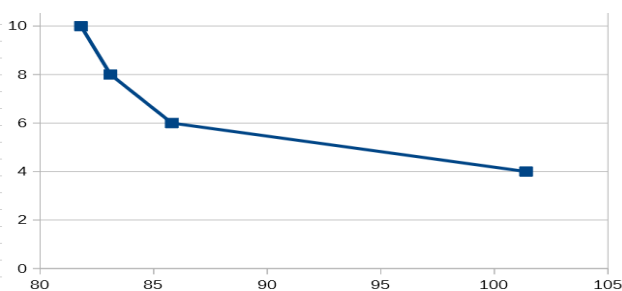


Fig -11 Graph of mesh convergence

### 3.3 Fatigue analysis results

The SN curve indicates that the life of the beam under the alternating low cycle stress range, the endurance limit is at about 225 Mpa.

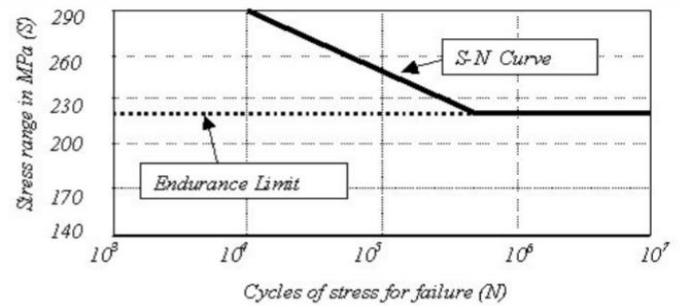


Fig -12 Sn curve of fatigue life

As per goodman equation,

Equivalent stress = Stress Amplitude  $(1 - \text{Ratio of mean stress} / \text{ultimate stress})$

Stress amplitude : 101 Mpa tensile and 205 Mpa in compression =306 Mpa

Mean stress = 153 Mpa

Ultimate stress = 520 Mpa

Equivalent stress = 214 Mpa (calculated.)

### 4. CONCLUSION

Stress analysis of weld is performed for the lateral and vertical loading from the structure. The Column is tested for the root weld stress by comparing with and without the weld. The weld stress is calculated based on the 3d mesh of the 8 mm weld. The result show that the weld is safe and the stress is at the root of the column and at the tip of the weld. Not at the root of the weld. This shows that the column is safe from deflection and stress. In order to validate the mesh, a mesh dependency check is performed by varying the global element size of the weld region. The appropriate results were found at 4 mm global size. The stress obtained in this mesh is used for the Fatigue life. The SN curve indicates that the life of the beam under the alternating low cycle stress range, the endurance limit is at about 225 Mpa. As the stress range goes higher the fatigue life drops lower. The maximum tensile stress is found to be at 101.4 Mpa. As per goodman equation of equivalent stress (214 MPa) the number of cycles are well within the range of base endurance limit. So the structure is safe from the fatigue endurance point of view.

**REFERENCES**

- [1] D.Radaj 'Theory of forces and stresses in spot welded overlap joints',1996.
- [2] A.Chattopadhyay, G.Glinka, M.El-Zein, J Qian and R.Formas 'stress analysis and fatigue of welded structures'
- [3] Niemi E. 'Stress determination for fatigue analysis of welded components', Doc. IIS/IIW-1221-93, Abington Publishing, Cambridge, UK, 1995.
- [4] Hafiz Waqar Ahmad , Jeong Ho Hwang, Ju Hwa Lee and Dong Ho Bae.'Welding Residual Stress Analysis and Fatigue Strength Assessment of Multi-Pass Dissimilar Material Welded Joint', Sungkyunkwan University, Suwon, Korea.
- [5] Rajlaxmi N. Mhetrei & S.G. Jadhav 'FINITE ELEMENT ANALYSIS OF WELDED JOINTS', Mechanical Engineering Dept. VJTI, Mumbai, India.
- [6] MUSTAFA AYGÜL 'Fatigue Analysis of Welded Structures Using the Finite Element Method'. Chalmers University of Technology.