

Design and Development of Drain Cleaner Machine for Waste Management

Prince Chawla¹, Vishal Garg², Navdeep Singh Randhawa³

¹Department of Mechanical Engineering, Swami Vivekanand Institute of Engineering & Technology Banur, India

^{2,3}Department of Electronics & Communication Engineering, Swami Vivekanand Institute of Engineering & Technology Banur, India

Abstract - presently a-days despite the fact that mechanical seepage assumes a fundamental part in every modern application in the best possible transfer of sewages from enterprises and plugs are still a testing assignment. Waste funnels are utilizing for the transfer and lamentably once in a while there might be loss of human life while cleaning the blockages in the waste Drain cleaner machine is the system installed in an open canal, river or drainage passage so that manual extraction of waste to be replaced through it. This helps us to stop the spreading of diseases in between humans by manual working in garbage waste. The main motive of this project is to design a drain cleaner machine to removing plastic & other waste dump from sewage water by using grids, pulleys, belt drives and motor arrangement.

Keywords—Water waste; Drain Cleaner Machine; components of machine

I. INTRODUCTION

The Drainage framework cleaner is a machine which shields the earth from various sorts of natural dangers through the advancement squander administration by the expulsion of rubbish from the seepage framework. These squanders when not evacuated wind up settling in private places where these squanders are smoldered in this way bringing on environmental change generally these squanders hinder the waste frameworks along these lines creating flooding. This machine is designed in that manner which produces movement for its capacities without anyone else's input through the activity of running water subsequently removing the threats of the driving the machine by different wellsprings of force in view of the cruelty of the rain on these different sources.[1]

The Drain cleaner machine is the system installed in an open canal, river or drainage passage so that manual extraction of waste to be replaced through it. This machine has big advantage to avoid the spreading of diseases in between humans by manual working in garbage waste. Plastic & other waste dump & block the flow of water in Canal & Rivers near the bridges support pillars, so it can extract out from river & canal & allow the water to flow without any obstacle. After that it may pass through conveyors to recycling plant. It is used to remove the sewage water mechanical impurities.

As a mechanical engineer, before the implementation of this project we checked the feasibility and characteristics of the project. This report provides an extensive view about the designing and development aspects of the drain cleaner

machine. This project contains set of vertical parallel rods forming filtering screen, grids, sprockets, chain drives and motor arrangement to removing plastic & other waste dump from sewage water.

The related work about drain cleaner machine is given in section II. The section III describes the problem formulation. The section IV discussed about the components of this machine and section V explains the different characteristics, designing specifications and working of the machine. The advantages of the machine are given in section VI along with the conclusion in section VII.

II. LITERATURE REVIEW

Drain cleaner machine contains the set of vertical parallel rods or square pipes forming filtering screen and it is mounted in frame with possibility of motion. The vertical rods are mounted with gaps normally relative direction of the motion to liquid flow. The cross section of grid rods are in the form of wedge with rounded edges and its base turned towards flow of sewage water. Filtering screen of grid includes separate interchangeable sections secured to cross rigidity ribs of frame of grid [2]. Two endless chains are driven to motion with use of sprockets at sides of grid together with rake arranged between them and being in the form of set of toothed plates whose teeth engage with said gaps. Rigidity rib arranged in sewage water is in the form of bent metallic plate to which rubber strip is secured. Lip of grid frame base is slightly raised over duct bottom by regulated height and it is in the form diffuser. Guides for changing motion direction of rake are provided with centering gaskets arranged upstream and downstream filtering screen [3].

The plan of the known specialized arrangements is impractical to utilize a grinding with generally little openings, i.e., for fine purging of sewage. The mechanical mesh rake sort, mounted on the casing with the likelihood of responding development, containing an arrangement of vertical parallel poles framing a channel screen, an area of which has a trapezoidal shape, secured with openings opposite to the heading of stream of waste water, two unlimited chains introduced by marks on each side of the cross section can move together with set between them with a rake, made as plates with the teeth stretching out into the openings, guides for altering the course of development of the rake [4].

III. PROBLEM STATEMENT

Wastewater is characterized as the stream of utilized water from homes, organizations, businesses, business exercises and foundations which are subjected to the treatment plants by a carefully designed and engineered network of pipes. There is substantial number of machines are utilized for expelling out the squanders from channels. Each unique spring is liable to these imperatives where variety of strengths and arrangement happens. To discover an answer for the issue of water logging because of plastic, thermocol, metal, and so forth. To treat issues like malaria fever, typhoid, and so forth caused because of water aggregation.

IV. COMPONENTS OF DRAIN CLEANER MACHINE

Drain cleaner machine consists of the following components to fulfill the requirements of complete operation.

A. CHAIN DRIVES

Chain drive is a method for transmitting mechanical power starting with one place then onto the next. It is frequently used to pass on energy to the wheels of a vehicle, especially bikes and cruisers. It is likewise utilized as a part of a wide assortment of machines other than vehicles. Regularly, the power is passed on by a roller chain, known as the drive chain or transmission chain, disregarding a sprocket adapt, with the teeth of the rigging coinciding with the gaps in the connections of the chain. The apparatus is turned, and this pulls the chain putting mechanical compel into the framework.

B. SPROCKETS

A sprocket or sprocket-wheel is a profiled wheel with teeth, machine gear-pieces, or even sprockets that work with a chain, track or other punctured or indented material. The name "sprocket" applies by and large to any wheel where upon outspread projections draw in a chain ignoring it. It is recognized from an apparatus in that sprockets are never fit together straightforwardly, and varies from a pulley in that sprockets have teeth and pulleys are smooth.

Sprockets are utilized as a part of bikes, cruisers, autos, followed vehicles, and other apparatus to transmit rotating movement between two shafts where gears are inadmissible or to confer straight movement to a track, tape and so on. Maybe the most well-known type of sprocket might be found in the bike, in which the pedal shaft conveys an extensive sprocket-wheel, which drives a chain and also drives a little sprocket on the pivot of the back wheel. Early cars were likewise to a great extent driven by sprocket and chain instrument, a training generally duplicated from bikes.

C. MESH

A mesh is a barrier made of connected strands of metal, fiber, or other flexible/ductile materials. A mesh is similar

to a web or a net in that it has many attached or woven strands.

D. BUSH

A bush is a mechanical settling between two, potentially moving, parts, or a reinforced settling point where one mechanical gathering is connected to another. In an auto or other vehicle's suspension, bushes are utilized to interface the different moving arms and rotate focuses to the skeleton and different parts of the suspension.

E. BATTERY

An electric battery is a gadget comprising of at least one electro-chemical cells with outer associations given to control electrical gadgets, for example, spotlights, cell phones, and electric autos. A battery is providing electric energy to its positive terminal is known as the cathode and its negative terminal is the anode. The terminal stamped negative is the wellspring of electrons that when associated with an outside circuit will stream and convey vitality to an outer gadget. At the point when a battery is associated with an outer circuit, electrolytes can move as particles inside, enabling the concoction responses to be finished at the different terminals thus convey vitality to the outside circuit. It is the development of those particles inside the battery which enables current to stream out of the battery to perform work.

F. Wiper Motor

A wiper motor device which is used to convert the electric energy into mechanical energy. In wastage tub all the wastage is collected.

V. DESIGN SPECIFICATIONS AND WORKING OF MACHINE

G. Design Parameters

Shaft

Material used=Mild steel.

Length=910mm

Inner Diameter=21mm

Outer Diameter=24mm

Length between shaft to shaft=930mm

Power transmitted by the shaft = 108577.5105watt

Maximum Bearing Load

$L/g = 248.256/9.81 = 25.3064\text{Kg}$

If the weight exceeds more than the calculated weight the load on the bearing will increase due to which there will be improper rotation of the chain occurs.

Chain Drives

$P=11.372\text{mm}$. Chain length = $L= pLp = 2057.4 \text{ mm}$

Lifter

Length=610mm Breadth =120mm Gap between each lifter=700mm

Wastage Tub

Length =920mm

Breadth =610mm

Height =340mm

Area of the collecting bin = $1/2 \times L \times B = 280600\text{mm}$

H. Technical Specifications

TABLE I. Parameters

Technical parameters	
Nominal Voltage	12V
Nominal Power	50W
Nominal Current	1.0-1.5A
High Speed	75-76 rpm
Low Speed	50 rpm

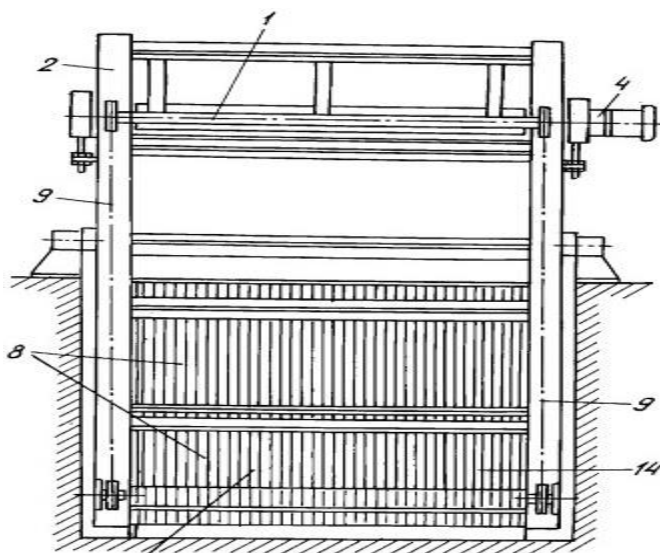

Figure I. Basic layout of the machine [5].

I. Working of the Machine

The drain cleaner machine helps us to clean small or big sewage through its mechanical design and functioning. This machine consists of parts such as motor, pulley, belts, grid, bucket etc. When we give power to this machine then motor starts functioning which gives rotation to pulley and through the help of pulley belt i.e. mount on pulley starts rotating from down to upward direction. As belt rotates

then grid joined to the bottom of the belt start rotating as well.

When grid completes one round from down to upward direction, it takes all the garbage material like waste bottles, plastic, tins etc. on the grid and drops it in the bucket attached at the back. This is how this machine helps us clean sewage or any garbage from water.

The gadget is a model can be utilized for fine cleansing of wastewater from mechanical polluting influences, be that as it may, when his erection, support and operation prepare shows various weaknesses. For instance, a complex is the establishment procedure of the rake with teeth because of the expanding mistake of the area of the teeth; the channel screen framework has a high hydrodynamic resistance; the collection of long filaments that are in the water, on the transverse ribs and the arrangement of hard beards at the base of the grid is the settling of sand and stones that prompts the development of base residue and the event of stale zones. The premise of the innovation is to make a mechanical mesh rake sort, permitting streamlining its establishment, repair and upkeep.

The issue is illuminated in mechanical mesh rake sort, settled on the edge with the capacity to move, including an arrangement of vertical parallel poles framing a channel screen mounted with openings opposite to the course of stream of waste water, two unlimited chains introduced by marks on each side of the grid can move together with set between them with a rake, made as plates with teeth. As indicated by the development the cross segment of the bars of the cross section has the type of a wedge with adjusted edges of the base confronting towards the stream of waste water, channel screen framework enrolled from independent tradable segments, mounted on the transverse ribs of the casing of the grid, with the rib being in water, made as a bended metal plate connected to it with an elastic band, the limit base casing network hoisted over the base of the channel at a flexible stature and is made as a cone, each rake comprises of an arrangement of plates with teeth, and aides for altering the course of development of the rake supplemented focusing plates introduced previously, then after the fact the separating screen.



The original development of drain cleaner machine is shown through the given pictures.



VI. APPLICATIONS AND BENEFITS OF THE MACHINE

- It is used almost in all types of Drainage (Large, Small & medium).
- This machine is mainly used in cleaning system
- Project to use this in efficient way to control the disposal of wastages and with regular filtration of wastages

J. Benefits

- Production cost is very low.
- No need of purchase special machine.
- It is mainly very useful to hold the lengthy in particular position.
- It's operated and maintenance is simple.
- It is compact and portable.
- It can be efficiently used.

K. Drawbacks

- Small vibration occurs due to wire brush wheel attachment.
- In order to avoid vibration the machine should be properly foundation with the floor.

VII. CONCLUSION

In the treatment system of drainage Waste water control by the motor, roller chain and sprocket, lifter and the collecting bin to achieve semi-automatic control of sewage waste water treatment. Drainage from industries is treated through this project to meet the national emission standards, with stable operation, low cost and good effect. After completing the project, conclude that our project is simple in construction and compact in size for use. Manufacturing of machine is easy and cost of the machine is less.

ACKNOWLEDGMENT

Word are in adequate and out of place and time particularly in context of express sincere filling in contribution of this work, is no more than a mere ritual it is our privilege to acknowledge with respect and gratitude, the keen valuable and ever available guidance reddened us by Er. Dheeraj Dhiman, Assistant professor and head of the Mechanical Engineering department without various console and able guidance we would have been unable to complete our project in these manners.

REFERENCES

- [1] Sall, N., Sadique, C. M. Z., Gawde, P., Qureshi, S., & Singh, S.; "Drain Waste Water Cleaner", . Global Journal of Research In Engineering, Vol. 16, No. 1, 2016
- [2] Daniels, NDUBUISI C.; "Drainage System Cleaner A Solution to Environmental Hazards", International Refereed Journal of Engineering and Science (IRJES), Volume 3, Issue 3, PP. 54-60, 2014.
- [3] U. L, Ganesh; V Rampur. Vinod; "SEMI-AUTOMATIC DRAIN FOR SEWAGE WATER TREATMENT OF FLOATING MATERIALS", International Journal of Research in Engineering and Technology, Vol. 5, No. 7, Jul-2016,
- [4] Astrup, T., J. Mollee, and T. Fruergaard; "Incineration and co-combustion of waste: accounting of greenhouse gases and global warming contributions", Waste Management & Research, Vol. 27, PP. 789-799, 2009.
- [5] <http://russianpatents.com/patent/230/2307696.html>