

Review of Design and Manufacturing of Die and its Operation on Sheet

Mr. Jadhav Aniket N¹, Mr. Khairnar Amol B², Ms. Lipte Puja D³, Ms. More Pushpawati M⁴,

Prof. Ghodake Arvind P⁵

^{1,2,3,4}BE, Dept of Mechanical Engineering, S.N.D. COE & RC Yeola, Maharashtra, India

⁵Asst. Professor, Dept. of Mechanical Engineering, S.N.D. COE & RC Yeola, Maharashtra, India

Abstract - Conservative die performs one or many operations at different steps in every time the ram descends. Punching of a metal sheet is widely used in manufacturing companies by its applications. This can be used to make the required shape or to process a hole or punched hole. There are many household items are being made of using die and punching operation. This operation includes parts such as punch which required the force and it's motion, on metal sheet load is gradually applied, in blanking process gives the required shapes of sheet and blank holder is used for holds the sheet on its position. When force is increased the some preventions is to be taken for blanking operation. Because of issue is difficult even when the blank holding.

Key Words: Conservative die, sheet, blank die.

1. INTRODUCTION

Conservative die is set of assembled die in which one or many sheet metal cutting operation can be carried out at a single cycle, for this process each and every tool is loaded after that in a sequence as per this operation needed. The sheet metal component are widely used in the day today life, it is mostly used in many household electrical component to the big industries such productions like TV, camera, electrical ovens, computer as well as in automotive parts, cavitation industries to make the product cost effective and less in weight. For increasing the performance of product.

In flatterring operation, press and shearing is procedure of cutting sheet metal without producing the chip. After applying the force the stresses induced in material can be done by the punch and die. In penetration, load further increases and the punch starts to penetrate the material to a certain depth and starts to force the metal sheet into the die portion, in this stage a bright surface finish on both the strips and the blank is done. Hence this stage is called penetration stage.

The punching tool is also a metal forming machine tool. It is designed for sheet metal operation by applying hydraulic force or mechanical force. In sheet metal operation the punching press is further divided into two parts for cutting operations and forming operations. In cutting operations the metal work piece is stressed up to ultimate strength point and the shear stresses develops into the metal sheet while forming operations are used to change the shape of metal sheet as per the requirement.

2. OBJECTIVES

1. To find shear stress, equivalent stress & stress concentration of medium carbon steel sheet.
2. Analysis using ANSYS.
3. To design drill holder and bush bearing.

2.1 Conservative die

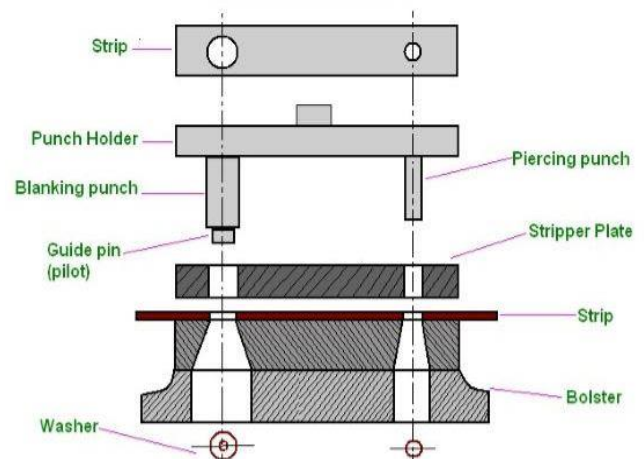

Fig 2.1 Model of Conservative die

Conservative die is also called as a Progressive die, it consists of punch holder with two punches namely blanking punch and piercing punch. Conservative die perform cutting and forming operations typically on continuous sheet metal. These operations are usually performed at two or more stations simultaneously.

Pilot holes or slots are guided by positioning of the stock at each station. Unwanted material is cut out leaving one or more tabs, ribbons, or bridges to connect the partially completed part to the strip until completion, as the stock advances through the die stations.

Along with cutting and forming operations within a single progressive die arrangement, significant cost savings are realized on mass production runs. The production volume as well as part complexity plays an important role in progressive die design.

Table 2.1 Bill of material

Sr.no	Parts Name	Qty.
1	Bottom plate	1
2	Guide rod	4
3	Top plate	1
4	Punch 10 cm	2
5	Die	1
6	Punch 8.5 cm	4
7	Side punch	1
8	Rectangular punch	1
9	Triangular punch	2
10	Bending single tool	1
11	Top shoe	1

2.2 Material Properties

Material properties like density, coefficient of friction, Young’s modulus, Poisson’s ratio, coefficients of Expansion & friction will have to be defined. In this study the different materials are used for Punch, Die and metal sheet material.

Table 2.2 Material properties (Punch, Die and Sheet)

Medium Carbon Steel	
Density	8000 Kg
Young’s Modulus	21300 Mpa
Poissions Ratio	0.33
Bulk Modulus	1.752 1e+10
Shear Modulus	8.230 3e+09
Tensile Yeild Strength	1550mpa
Comp. Yeild Strength	1450mpa
Tensile Ultimate Strength	1893 Mpa
Comp. Ultimate Strength	1905 Mpa

3. CONCLUSIONS

Punching operation has different application and its pre-analysis is necessary.

Sheet needs to be analyzed in detail as maximum deformation and stress get generated in it.

Crack initiation is more at the corner of the blanking punch because maximum stress is more at the corner of the blanking punch.

ACKNOWLEDGEMENT

The authors with gratitude thanks to HOD Dr. Sadhawani S.V. for permitting us to do the project work at SND COE & RC Yeola, Maharashtra, India. and necessary help and cooperation, and also express deep sense of gratitude to Prof. Ghodake A.P. (Guide). and Mechanical Engineering Department staff for the necessary help & technical support.

REFERENCES

- [1] E. Gustafssona, M. Oldenburg, A. Jansson, “Design and validation of a sheet metal shearing experimental procedure”, Journal of Materials Processing Technology 214 (2014) pp. 2468–2477
- [2] Sutasn Thipprakmasa, Siriporn Rojananan, Pravitr Paramaputi, “An investigation of step taper shaped punch in piercing process using finite element method”, journal of materials processing technology (2008) pp. 132–139
- [3] C. Husson, J.P.M. Correia, L. Daridon, S. Ahzi, “Finite elements simulations of thin copper sheets blanking Study of blanking parameters on sheared edge quality”. journal of materials processing technology (2008) pp. 74–83
- [4] Kaushik S, “Design and Fabrication of a Special Purpose Hydraulic Press Performing Punching Operation”. International Journal of Science and Research. (2013) pp. 61-67.
- [5] Khichadia BN, Chauhan DM, “A Review on Design and Analysis of Mechanical Press Frame”, International Journal of Advance Engineering and Research Development. (2014). pp. 1–7.