

Analysis of cascaded H-bridge Multilevel inverter with reduce component count employing transformer

Gaurishankar Soni¹, Arpan Dwivedi²

¹M.Tech Scholar, Department of EEE, SSTC- SSITM Bhilai, C.G., India

²Sr. Asst. Professor & Head, Department of EEE, SSTC- SSITM Bhilai, C.G., India

Abstract – in this paper, a novel cascaded transformer multilevel inverter is proposed. The number of the switching component is reduced in the proposed topology. Several cascaded low frequency transformers are used in this topology. A literature review is carried out and from that only one bidirectional switch is employed rather than in case of conventional cascaded transformer multilevel inverter. Where four switching devices are required for each transformer. Compared to the conventional multilevel inverter, the number of dc voltage sources, switches, installation area and inverter cost is significantly reduced as the number of voltage steps increases then the structure of the proposed topology is employed in order to utilize a minimum number of switches and dc voltage sources, and produce a high number of output voltage steps. Switching power losses are also reduced in this topology.

Key Words: Multilevel Inverter; Transformer; DC voltage source

1. INTRODUCTION

Multilevel inverters are come out as the new breed for high power applications. Multilevel inverters have played a major role in most systems such as large motors, flexible AC transmission systems, power quality improvement devices and renewable energy converter. They mainly synthesize the staircase voltage waveform from many dc sources. Multilevel inverter approach enhances the usage of high - power and high voltage electric motor drive systems.

Switching scheme of multilevel inverters are categorized into high switching frequency methods such as SPWM strategy and low switching frequency techniques, often equal to fundamental switching frequency of the components, which create stepwise output voltage waveform. second category includes three major switching strategies so- called optimized harmonic stepped waveform, selective harmonic mitigation PWM and optimal minimization of the THD. Selective harmonic elimination is as effective method to mitigate the low - order harmonic components.

In this paper a cascaded H- bridge reduced switch multilevel inverter is proposed which compromises of several low frequency transformers. Due to the reduction in number of switching components the size. And the cost of realization also reduces selective harmonic elimination technique is employed to get a high quality output voltage.

2. Literature Survey

A brief overview of earlier investigation carried out on cascaded multilevel H- bridge inverter employing transformer is presented in this paper.

- a) A comprehensive review of a recently proposed multilevel inverter is presented by KK Gupta. This paper presented the topology comprises of floating input dc sources connected in opposite polarities through power switches. The structure requires lesser active switches as compared with conventional cascaded H- bridge topology with much reduced switching losses. The topology is analyzed for both symmetric and asymmetric source configurations. Also, a new algorithm for asymmetric source configuration suitable for CCS- MLI is proposed. (K.K. Gupta et al 2013)

The circuit diagram of proposed CCS MLI for five - level output is shown in figure -

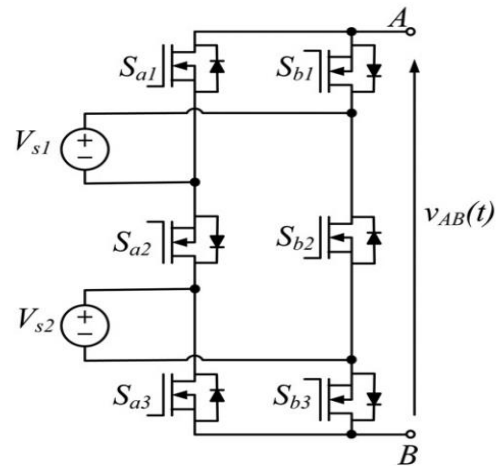

CCS - MLI as proposed for five - level output

- b) The multilevel inverter topologies for high power - medium voltage energy control is proposed by Jose Rodriguez. This paper presented the most important topologies like diode - clamped inverter (neutral point clamped), capacitor clamped (flying capacitor) and cascaded multi cell with separate DC sources. Emerging topologies like asymmetric hybrid cells, soft - switched multi level inverters, control and modulation methods for the family of converters, namely multi level

sinusoidal pulse width modulation, multilevel selective harmonic elimination, and space- vector modulation were analyzed.

- c) A new modified hybrid H – bridge multilevel inverter with lesser number of switches compared to conventional multilevel inverter is proposed by Balamurugan. Reduction in number of switches reduces the switching losses and improve the efficiency. (Balamurugan et al 2012)

The schematic of multilevel inverter proposed by Balamurugan was as shown in figure.

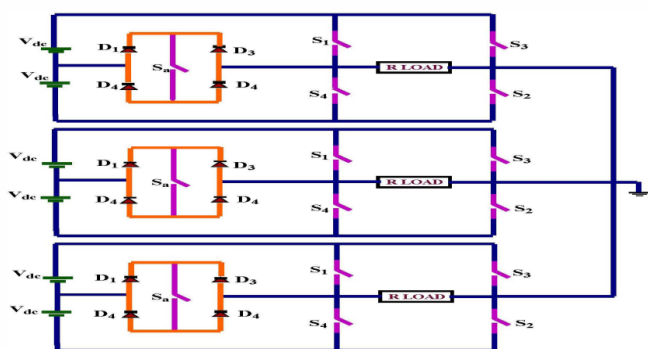

Schematic of chosen three phase, five level modified cascaded hybrid H – bridge inverter using less number of switches

Comparison between existing system and proposed system –

TYPE	Conventional C MLI	Chosen hybrid H- bridge cascaded inverter
No. of Switches	24	15
No. of clamping diodes	24	15
No. of DC Sources	6	6

- d) A new multilevel converter topology that has 53 steps with minimum power electronic switches was introduced by Javad Ebrahimi. The optimal structure was based on the investigation such as minimum number of switches, capacitors, and minimum standing voltage on switches for producing maximum output voltage steps. The best way to keep the number of

switches minimum for a certain number of voltage steps having the structure consisting of units with three switches was used. A new algorithm to determine the magnitude of DC voltage sources was also presented. (Javad Ebrahimi et al 2012)

- e) A new topology of a cascaded multilevel inverter is used by Javad Ebrahimi. The proposed topology is based on a cascaded connection of single – phase sub multi level inverter units and full – bridge converters. Then, the structure of the proposed topology is optimized. (Javad Ebrahimi et al 2012)
- f) The relevant references in the field of topologies and modulation strategies of multilevel is investigated by Bindeshwar Singh. Fundamental principles of different multilevel inverters were introduced systematically. Finally cascaded multilevel inverter with separate DC sources was used to decrease the harmonic distortion at the output voltage waveform without decreasing the inverter power output. (Singh et al 2012)

Result

By the study of several papers the performance analysis of cascade H – bridge multilevel inverter with reduce component count employing transformer is done. This inverter consists of four transformer, two main switches and four bidirectional transformer switches. By the study of previous papers presented , we obtain The result that by reducing switching component switching losses are decreases and more power at output is obtain , also the harmonic distortion of the proposed multilevel inverter is minimized. From the above paper it is concluded that the multilevel inverter of cascade H - bridge type with reduce component count employing transformer is proposed. This topology consists of a DC voltage source and several single phase transformers. Two, main switching devices are used to change the polarity of the input voltage and for each transformer a bidirectional power switch is used. Compare to the traditional transformer based multilevel inverter , using less switching devices as well as gate drivers in the proposed topology leads to cutting down in power losses , smaller size and low cost.

Conclusion

In this paper , a cascaded transformer multilevel inverter with reduced number of switching components performance are studied by the review of previously presented papers and literatures . This multilevel inverter utilizes low – frequency single – phase transformers and A DC voltage source. This configuration can reduce the number of

switches in comparison with conventional cascaded transformer multilevel inverters. Selective harmonic elimination technique is applied to mitigate the low order harmonic components. In order to verify the operation and performance of the proposed inverter analysis of the circuit diagram given in figure is done.

REFERENCES

- 1) K. K. Gupta, Shailendra Jain "Comprehensive review of a recently proposed multilevel inverter", IET Power Electron 2012.
- 2) Jose Rodriguez et al "The multilevel topologies for high power medium - voltage energy control 2007
- 3) C. R. Balamurugan , S.P. Natarajan , V. Vidhya " A new modified hybrid H - bridge multilevel inverter Using lesser number of switches", International Conference on computation of Power, Energy, Information and Communication, 2013.
- 4) Bindeshwar Singh, Nupur Mittal , S.P.Singh , " Multilevel Inverters: A literature survey on topologies and Control strategies." 2nd International Conference on Power, Control and Embedded Systems 2012.
- 5) H. Khounjahan , M.R. Banaei , Amir Farakhor , " A new low cost cascaded transformer multilevel inverter Topology using minimum number of components with modified selective harmonic elimination modulation. Ain Shams Engineering Journal 2015.
- 6) Javad Ebrahimi , Ebrahim Babaei , Gevorg B Gharehpetian , " A new Multilevel Converter Topology with Reduced Number of Power Electronic Components". IEEE TRANSACTION ON INDUSTRIAL ELECTRONICS, VOL-59, 2012.
- 7) J. Rodriguez , L.G. Franquelo, S. Kouro et al.: 'Multilevel converters: an enabling technology for high-power applications' Proc. IEEE, 2009, 97(11), pp. 1786-1817.
- 8) M. Malinowski, K. Gopakumar, J. Rodriguez, & M. A. Perez, - A survey on cascaded multilevel inverters, IEEE Trans. Ind. Electron. , vol 57, no.7, pp. 2197-2206, July 2010.
- 9) J. Rodriguez, J-S. Lai, & F.Z. Peng,- " Multilevel inverters: A survey of topologies, controls, & applications, " IEEE Trans. Ind. Electron, vol.49, no.4, pp.724-738 Aug.2002.
- 10) K.A. Corzine, M.W. Wielebski, F.Z. Peng, & J. Wang, "Control of cascaded multilevel inverters", in Proc. Elect. Mach. Drives Conf., 2003, vol.3, pp. 1549-1555.

- 11) J. Jamaludin, N Abd rahim, Hew wooiping. Multilevel voltage source inverter with optimized usage of bidirectional switches. IET Power Electronics.2015, 8(3):378-390.

BIOGRAPHIES

- 1) **Mr. Gaurishankar Soni** has pursuing his Master of Technology in Power Systems, EEE Department, Shri Shankaracharya institute of Technology and Management Bhilai, Chhattisgarh, India. He completed his graduation from Christian college of Engineering and Technology, Bhilai, Chhattisgarh, India in 2014. His areas of interests includes Power System, Control Systems and Network Analysis.
- 2) **Mr. Arpan Dwivedi** completed B.E. in Electrical and Electronics Engineering from RGPV University Bhopal, M.P, India in 2007 and Master of Technology from RGPV University in 2010. He is currently pursuing Ph.D. in Department of Electrical Engineering, RKDFIST, SRK University, Bhopal, (M.P.). His main research work focuses on Power Electronics converter development for Renewable energy systems, Hybridization of multiple sources. He has 10 years of teaching experience and 2 years of research Experience.