

Underground Three Phase Supply Fault Detection System

Kumar Saurav¹, Prakash Kumar²

^{1,2}Student, Dept of Electrical Engineering, University of Petroleum and Energy Studies, Dehradun, India

Abstract:- This article is based on the concept of Ohm's law. Any fault like Line to Ground or Line to Line occurs, the current varies, since current is directly proportional to the voltage and inversely proportional to the resistance. So voltage drop in underground cable vary depending on the length of the cable. Three phase supply line is represented by different sets of resistors and the fault in line is detected by the change in voltage level using ADC converter. The Atmega microcontroller will perform the necessary calculations to detect the type of fault in particular phase and it will display it's location on the LCD screen. While in practical situations this concept is implemented by using a relay instead of switch for automatic tripping to detect the fault.

Key Words: Ohm's law, Underground cable, Line to Ground Fault, ADC, Microcontroller.

1. INTRODUCTION

Analysis of the fault in the underground cable has always been a challenging task. With advancement in technology the conventional methods have become more efficient and other fault detection methods are also gaining popularity. Method of OHM'S law for detecting the underground cable faults is the most widely used and well-known fault detecting technique [1]. In past few decades there were many advancements had done in this method of fault detection technique, now a days, Microcontrollers can now be used to detect the faults in underground cable

As India move towards the technical advancements in the field of underground cable, and detection of fault in the underground cable, it become crucial for students like us who are pursuing their B. Tech in electrical engineering to develop the efficient technique related to detect the faults in the underground cable. Major portion of this article includes design and development of the system to detect the faults in the underground cable. Design and development of the circuit was carried out at a electrical lab of the University of Petroleum and Energy Studies, Dehradun.

1.1 Types of Faults

OPEN CIRCUIT FAULT:-

Open circuit occurs mainly due to the break in the conductor of a cable, it is called open circuit fault. Any interruption in the circuit, such as an open switch, a break in the wiring, or a component such as a resistor that has changed its resistance to an extremely high value will cause current to cease [2].

The EMF will still be present, but voltages and currents around the circuit will have changed or ceased altogether

SHORT CIRCUIT FAULT:-

When two conductors of a multi-core cable come in electrical contact with each other due to insulation failure, it is called as short circuit fault. A short circuit is simply a low resistance connection between the two conductors supplying electrical power to any circuit [3]. This results in excessive current flow in the power source through the 'short,' and may even cause the power source to be destroyed.

GROUND FAULT

When the conductor of a cable comes in contact with the earth, it is called as earth fault or ground fault. A ground fault is a inadvertent contact between an energized conductor and ground or equipment frame [4]. The return path of the fault current is through the grounding system and any personnel or equipment that becomes part of that system. Ground faults are frequently the result of insulation breakdown

1.2 Fault Detection Methodology

The AC source 230V/50Hz is step down using step down transformer. The step down AC source is rectified by the diode bridge rectifier to get ripple DC voltage, and further with the help of a capacitor we will able to get a pure DC. Further the 9V DC voltage is reduced to 5V using voltage regulator LM7805.

The ripple free 5V DC voltage is fed to the microcontroller and also distributed where it is required all over the circuit.

This fault detection technique is based on the concept of Ohm's law. Any fault like Line to Ground or Line to Line occurs, the current varies, since current is directly proportional to the voltage and inversely proportional to the resistance.

So voltage drop in underground cable vary depending upon the length of the cable [5] and the change in voltage level is detected by ADC converter. So ADC analog voltage data is converted to digital form and it will fed to the microcontroller to perform the necessary calculations to detect the faults in phase and its location. Hence it will display on the LCD screen.

2. Hardware Requirements.

Table-1:- Hardware Specifications

S. No	Equipment Name	Specification	Quantity
1.	Step down Transformer	230V/9V	1
2.	Voltage Regulator	7805,9V/5V	2
3.	Diode	IN4007	6
4.	Capacitor	1000microF	5
5.	Microcontroller	Atmega-16	1
6.	Lcd	16*2	1
7.	Potentiometer		1

2.1 Hardware Detail Specifications

909 Step Down Transformer- Good quality step down transformer. All primary winding rated at 220/240Vac. Suitable for use with domestic electricity.

Specifications-

- Type- Step down.
- Input Voltage- 220-240V AC.
- Outputs Voltage- 9-0-9V AC.
- Current- 500 mA

LM7805 Voltage Regulator-7805 fixed voltage integrated-circuit voltage regulator is designed for a wide range of applications. Each of these regulators can deliver up to 1 A of output current.

In addition to use as fixed-voltage regulators, these devices can be used with external components to obtain adjustable output voltages and currents [6], and also can be used as the power-pass element in precision regulator

Specifications-

- Output Current up to 1A
- Output Voltages of 5, 6, 8, 9, 10, 12, 15, 18, 24V
- Thermal Overload Protection
- Short Circuit Protection
- Output Transistor Safe Operating Area Protection

IN4007 Diode- It is a general purpose plastic rectifier used to convert AC source into DC.

Specifications-

- Low forward voltage drop.
- Low leakage current.
- High forward surge capability.
- Operating voltage- 1000 V.
- Operating current- 1 Amp.

1000 Micro Faraday Capacitor- Capacitor is used in the circuit to eliminate the ripple and make output voltage pure DC.

Specifications-

- Charges-1000uF
- Max voltage-0-25V
- Tolerance -±20% Tolerance
- Temp-85 to 105°C Max Temperature
- Type-Radial Electrolytic Capacitor

Microcontroller (Atmega-16) - ATmega16 is an 8-bit high performance microcontroller from the Atmel's Mega AVR family. Atmega16 is a 40 pin microcontroller based on enhanced RISC (Reduced Instruction Set Computing) architecture with 131 powerful instructions [7]. It has a 16 KB programmable flash memory, static RAM of 1 KB and EEPROM of 512 Bytes. Most of the instructions execute in one machine cycle. It can work on a maximum frequency of 16MHz.

Specifications-

- High-performance, Low-power Microcontroller
- Advanced RISC architecture
- 131 powerful instructions
- Most Single-clock cycle execution
- 32 x 8 general purpose working registers
- Fully static operation
- On-chip 2-cycle multiplier
- 512 Bytes EEPROM
- 40-pin DIP

LCD(16*2)-LCD (Liquid Crystal Display) screen is an electronic display module and find a wide range of applications. A 16x2 LCD display is very basic module and is very commonly used in various devices and circuits. These modules are preferred over seven segments and other multi segment LEDs. The reasons being: LCDs are economical; easily programmable. A 16x2 LCD means it can display 16 characters per line and there are 2 such lines. In this LCD each character is displayed in 5x7 pixel matrix. This LCD has two registers, namely, Command and Data.

Specifications-

- Character LCD 16x2
- Built-in controller
- +5V power supply only
- Negative voltage optional for +3V power supply
- 1/16 duty cycle

3. Power Supply Circuit- The AC source 230V/50Hz is step down using 909 step down transformer. The AC step down voltage is rectified by using the diode bridge rectifier to get ripple DC voltage, and further with the help of capacitor we are able to eliminate a ripple and finally get a pure DC voltage. Further the 9V DC voltage is step down to 5V using voltage regulator LM805. This 5V step down voltage is fed to the microcontroller and then distributed all over the circuit as per requirements.

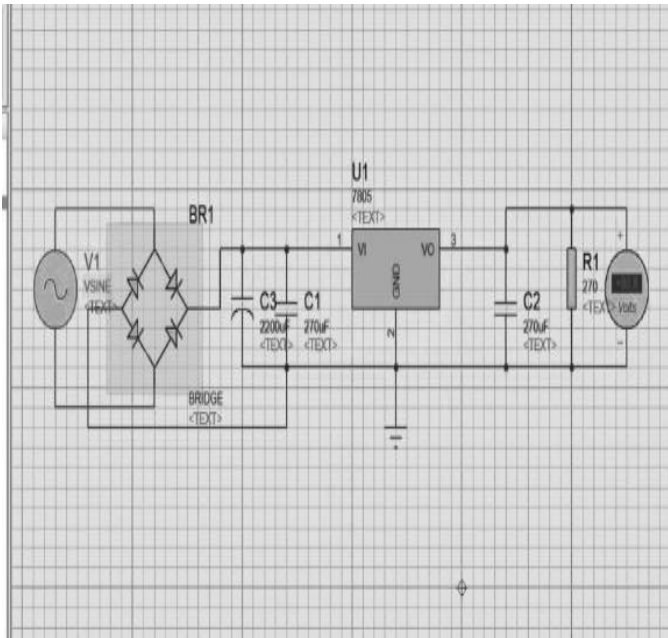

Fig1- Power Supply Circuit

3.1. Underground Cable Fault Detection Circuit- Working of the fault detection circuit is mainly based on the basic concept of Ohm's law.

Any fault like Line to Ground or Line to Line occurs, the current varies. Although current is directly proportional to the voltage and inversely proportional to the resistance. So voltage drop in underground cable vary depending upon the length of the cable.

In fault detection circuit three phase supplies is represented by three different set of resistors. The fault in line is detected by the change in voltage level using ADC.

So ADC analog voltage data is converted to digital form it will fed to the microcontroller to perform the required calculations to detect the fault in phase and it's locations Hence it will display on the LCD screen.

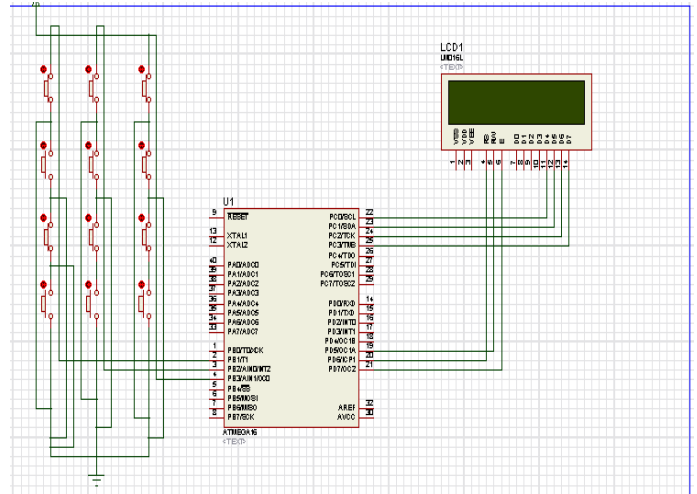

Fig2- Proteus Fault Detection Circuit

4. Compiler & Stimulation Software-

PROTEU SIMULATOR- Proteus is software for microprocessor simulation, schematic capture, etc. It is developed by Labcentre Electronics for an electronic design automation [8]. This enables its use in a broad spectrum of project prototyping in areas such as motor control, temperature control and user interface design.

Compiler (AVR Studio-4) - AVR studio is an Integrated Development Environment (IDE) by ATMEL for developing applications based on 8-bit AVR microcontroller. Prior to installation of AVR Studio you have to install the compiler Win AVR.

Embedded C-It is a set of language extensions for the C programming language by the C standards committee to address commonality issues that exist between C extensions for different embedded systems. Historically, embedded C programming requires nonstandard extensions to the C language[9] in order to support exotic features such as fixed-point arithmetic, multiple distinct memory banks, and basic I/O operations.

AVR Microcontroller Programming- The AVR microcontroller is excellent with C code because it was designed with C in mind. Atmel have also made it easy to use C in AVR Studio, as Win AVR compiler can run from within AVR Studio just like the assembler [10]. Win AVR is based on the free GNU-GCC compiler and it is much friendlier.

4.1 Stimulation Code

```
#include<avr/io.h>
#include<util/delay.h>
#include "lcd.h"
//uint16_t ReadADC(unit0_t);
void main()
{
  DDRB=0b11111111;
  InitLCD(0);
  LCDClear();
  LCDWriteStringXY(0,0,"Underground Wire");
  LCDWriteStringXY(1,1,"Fault Detector");
  _delay_ms(2000);
  LCDClear();
  int a=0;
  while(1)
  {
    PORTB=0b0000011;
    a=ReadADC(0);
    LCDWriteStringXY(0,0,"R");

    if((a>670)&&(a<690))
    {
      LCDWriteStringXY(2,0,"2Km");
    }
    if((a>800)&&(a<830))
    {
      LCDWriteStringXY(2,0,"4Km");
    }
    if((a>865)&&(a<890))
    {
      LCDWriteStringXY(2,0,"6Km");
    }
    if((a>900)&&(a<915))
    {

```

Fig3- Code 1

```
{
  LCDWriteStringXY(2,0,"8Km");
}
if((a>960)&&(a<1025))
{
  LCDWriteStringXY(2,0,"OK");
}
_delay_ms(500);

PORTB=0b0000110;
a=ReadADC(0);
LCDWriteStringXY(0,1,"Y");

if((a>670)&&(a<690))
{
  LCDWriteStringXY(2,1,"2Km");
}
if((a>800)&&(a<830))
{
  LCDWriteStringXY(2,1,"4Km");
}
if((a>865)&&(a<890))
{
  LCDWriteStringXY(2,1,"6Km");
}
if((a>900)&&(a<915))
{
  LCDWriteStringXY(2,1,"8Km");
}
if((a>960)&&(a<1025))
{
  LCDWriteStringXY(2,1,"OK");
}
}
```

Fig4- Code2

```
}
_delay_ms(500);
PORTB=0b0000101;
a=ReadADC(0);
LCDWriteStringXY(8,1,"B");

if((a>670)&&(a<690))
{
  LCDWriteStringXY(10,0,"2Km");
}
if((a>800)&&(a<830))
{
  LCDWriteStringXY(10,0,"4Km");
}
if((a>865)&&(a<890))
{
  LCDWriteStringXY(10,0,"6Km");
}
if((a>900)&&(a<915))
{
  LCDWriteStringXY(10,0,"8Km");
}
if((a>960)&&(a<1025))
{
  LCDWriteStringXY(10,0,"OK");
}
_delay_ms(500);
}
```

Fig5-Code-3

5. CONCLUSION

Resulting conclusion for underground cable fault detection circuit can be drawn as:

- So designed circuit for the detection of fault in underground cable are successfully able to detect the short circuit fault between the range of km in cable .
- Designed circuit is successfully able to detect the phase in which fault is occur
- Circuit is successfully able to provide information about the distance of fault from the source in the cable.
- All the information about the type of fault and its distance from the source is successfully able to display on the LCD screen

ACKNOWLEDGEMENT

I would like to express my gratitude towards my parents & my mentor Dr Vineet Mediratta for their kind co-operation and encouragement which help me in completion of this project. I would like to express my special gratitude and thanks to Kushagra sir for giving me such attention and time.

REFERENCES

[1] Pahal, Sudesh, et al. "Underground Cable Fault Detection System." Advanced Research in Electrical and Electronic Engineering p- ISSN: 2349-5804.

[2] Yang, Xia, et al. "Fault location for underground power cable using distributed parameter approach." IEEE Transactions on Power Systems 23.4 (2008): 1809.

[3] Nandhini, T., et al. "Underground cable Fault Detection using Arduino."International Journal of Engineering Science 6460 (2017).

[4] Kuan, K. K., and Kevin Warwick. " Real-time expert system for fault location on voltage underground distribution cables."IEE Proceedings C (Generation, Transmission and Distribution). Vol.139.No. 3. IET Digital Library,1992 .

[5] Bo, Z. Q., G. Weller, and M. A. Redfern. "Accurate fault location technique for distribution system using fault-generated high-frequency transient voltage signals." IEE Proceedings-Generation, Transmission Distribution 146.1 (1999): 73-79.

[6] Aziz, Mohamed Mamdouh Abdel, Doaa khalil Ibrahim, and Mahmoud Gilany. "Fault location scheme for combined overhead line with underground power cable." Electric power systems research 76.11 (2006): 928-935.

[7] Komoda, Mitsuharu, et al. "Development of a current detection type cable fault locator." IEEE Transactions on Power Delivery 6.2 (1991): 541-545.

[8] Pardis, Robert J. "Buried cable fault locator with earth potential indicator and pulse generator." U.S. Patent No. 4,063,161. 13 Dec. 1977.

[9] Qihua, D. A. I. "The circuit design and simulation based on Proteus." Automation & Instrumentation 6 (2006): 028.

[10] Lin, WANG Meng CHEN. "Design and simulation of led display based on proteus [j]." Microcomputer Information 16 (2008): 098.