

# A REVIEW ON PERFORMANCE OF HYBRID RELAY SELECTION IN COOPERATIVE COMMUNICATION SYSTEM

VISHITA CHOUHAN<sup>1</sup>, PRAVEEN PATIDAR<sup>2</sup>

M.Tech(Student)<sup>1</sup>, Department of Electronics and Communication Engineering <sup>1</sup>, Lakshmi Narain College of Technology, Indore (M.P.), India<sup>1</sup>

Professor<sup>2</sup>, Department of Electronics and Communication Engineering <sup>2</sup>, Lakshmi Narain College of Technology, Indore (M.P.), India<sup>2</sup>

\*\*\*

**Abstract:** - Cooperative communication system (CCS) aims to reduce the effect of multipath fading. There are two types of protocol relay techniques, namely amplify and forward (AF) and decode and forward (DF). Hybrid relay selection (HRS) is a composite of AF and DF protocols where the relay will select one protocol using hybrid relay selection technique. If the information is accepted, then the relay node will pick to sent information with the DF protocol or vice versa. Hybrid relay protocols on cooperative communication system using AF relay protocol, DF, and hybrid with Selection Combining (SC) technique. Hybrid Relay Selection System is used to reduce Bit Error Rate.

**Key Words:** 1.Cooperative Communication System (CCS), 2.AF (Amplify and Forward) Relay, 3.DF (Decode and Forward) Relay, 4.Hybrid Relay Selection, 5.Selection Combining.

## 1. INTRODUCTION

Cooperative communication improves system by eliminating effect of multipath fading on wireless channel to improve system performance. There are two types of protocol relay techniques, namely amplify and forward (AF) and decode and forward (DF).

Protocols relay function is, (1) In AF (amplify and forward) the information on the relay nodes is amplified before the transmission of the destination node. And (2) DF (decode and forward) the information sent to each node is encoded firstly. The relay will select one protocol using hybrid relay selection (HRS) technique.

The Selected of the best relay based on the SNR parameter each protocol. In previous research has been proposed some cooperative communication systems and relay selection. Liu Tanxi proposed a performance analysis of hybrid relay selection on cooperative communication systems.

Trung Q, studied the performance gain of hybrid decode amplify forward on cooperative communication systems. Furuzan determines the SNR threshold limit chosen by the relay on the cooperative communication systems.

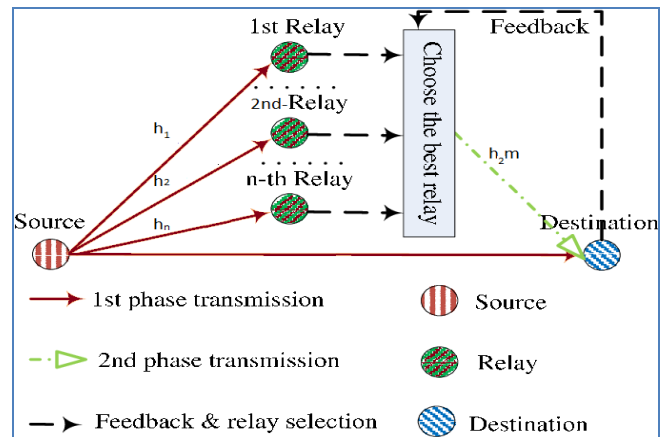

Fig -1: Relay Selection System

## 2. INTRODUCTION TO RELAYING TECHNIQUES

A relay network is a wide range network topology frequently utilized as a part of wireless networks, where the source and destination are interconnected using nodes. In its simplest form of cooperative network is composed of a source device, a destination device and a relaying terminal, which supports communication between source and destination. If the direct communication between source destination pair faulty then the overheard information can be relayed to destination by the relaying node.

In cooperative networks, a user does not only transmit is own information, but also helps other user to transmit their data by relaying their information. The process of relaying overheard information is called as relaying protocol and it can be categories as:

1. Fixed gain.
  - a. Amplify & Forward.
  - b. Decode & Forward.
  - c. Compress & Forward.
2. Adaptive.
  - a. Adaptive Decode & Forward Relaying.

Several basic relaying protocols are explained in following subheading.

**1. (a) Amplify and Forward (AF)**

A basic cooperative signalling is the amplify-and-forward method. As the name infers, the user then can amplify and re-transmit the received data in noisy for. The base station joins the data sent by the user and associate, and settles on an ending choice on the transmitted bit.

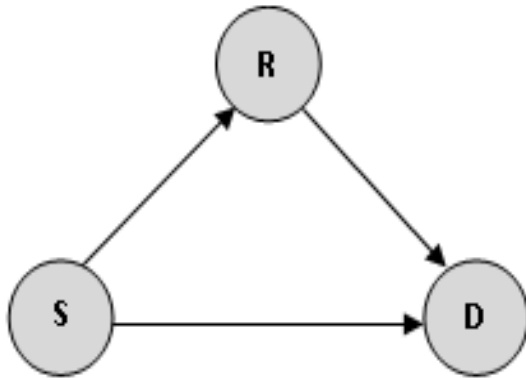

Fig -2: Amplify and Forward

Despite the fact that noise is amplified by cooperation, the base station gets 2 autonomously faded variants of the signal and can settle on better choices on the location of data.

**1. (b) Decode and Forward (DF)**

This scheme is may nearest to the thought of a customary relay. In this strategy a user needs to recognize the receiver's bits and after that retransmits the identified bits(Fig:3). The receivers may be allocated commonly by the base station, or through some other system. Consider two users collaborating with each other, yet in practical the main vital issue is that every user has a receiver that gives an additional (diversity) data path. The accomplish the same impact through other association topologies that evacuate the strict limitation of pairing.

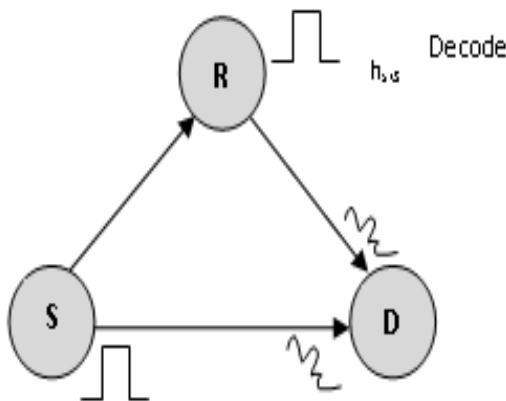

Fig -3: Decode and Forward

**1. (c) Compress and Forward (CF)**

In compress and forward scheme unlike as AF & DF relays will transmit the estimate of received signal to the destination node. This scheme is also known as Estimate and forward scheme(E&F). The received signal at any relay is first quantized and then compressed, the resulting signal will acquire less bandwidth.

**2. (a) Adaptive Decode and Forward (ADF)**

In Adaptive DF scheme if source is unable to transmit to relay node then it will retransmits the information to the destination node. This scheme is used only when the link between relay to destination terminal in known to have fewer errors. Adaptive DF uses link estimation to decide whether a particular relay is suitable for transmission or not.

**3. Literature Survey**

[1] Trung Q. Duong and Hans-Jurgen Zepernick, "On the Performance Gain of Hybrid Decode-Amplify-Forward Cooperative Communications", EURASIP, 2009. We investigate the performance of adaptive decode-forward (ADF), amplify-forward (AF), and hybrid decode-amplify-forward (HDAF) relaying protocol. Specifically, we derive the closed-form expression of symbol error probability (SEP) for these three relaying protocols. For the AF protocol, we derive a simpler and more tractable final result than previously published work. Furthermore, analyzing the high signal-to-noise ratio (SNR) regime, we derive an asymptotically tight approximation for SEP. The approximation is used to assess an important aspect between the three different relaying protocols, i.e., the SEP performance gain of HDAF over the two conventional relaying schemes ADF and AF. It is shown that the performance gain of HDAF over ADF and AF significantly depends on the relative value of channel conditions between source-to-relay and relay-to-destination links. Interestingly, it is shown that HDAF has no benefit compare to the two others if the relay is located close to the source. In contrast, the performance gains of HDAF over the ADF and AF scheme are remarkably large as the relay moves nearby the destination. Specifically, the numerical results given as well as our analysis indicate that for QPSK modulation, HDAF outperforms ADF and AF with a performance improvement by 5 dB and 6 dB, respectively.

[2] Yonghui Li, Raymond H.Y. Louie, Branks Vucetic, "Relay Selection With Network Coding in Two-Way Relay Channels", IEEE, 2010. In this paper, we consider the design of joint network coding (NC) and relay selection (RS) in two-way relay channels. In the proposed schemes, two users first sequentially broadcast their respective information to all the relays. We propose two RS schemes: 1) a single RS with NC and 2) a dual RS with NC. For both schemes, the selected relays perform NC on the received signals sent from the two users and forward them to both users. The proposed schemes are analyzed, and the exact bit-error-rate (BER) expressions are derived and verified through Monte Carlo simulations. It is shown that the dual RS with NC outperforms other considered RS schemes in two-way relay channels. The results also reveal that the proposed RS-NC schemes provide

a selection gain compared with an NC scheme with no RS and an NC gain relative to a conventional RS scheme with no NC.

[3] Tianxi Liu, Lingyang Song, Yonghui Li, QiangHuo, Bingli Jiao, "Performance Analysis of Hybrid Relay Selection in Cooperative Wireless Systems", IEEE, 2012. The hybrid relay selection (HRS) scheme, which adaptively chooses amplify-and-forward (AF) and decode-and-forward (DF) protocols based on the decoding results at the relay, is very effective to achieve robust performance in wireless relay networks. This paper analyzes the frame error rate (FER) of the HRS scheme in general wireless relay networks without and with utilizing error control coding at the source node. We first develop an improved signal-to-noise ratio (SNR) threshold-based FER approximation model. Then, we derive an analytical average FER expression as well as a high SNR asymptotic expression for the HRS scheme and generalize to other relaying schemes. Simulation results exhibit an excellent agreement with the theoretical analysis, which validates the derived FER expressions.

[4] Nhu Tri Do, Daniel Benevides DA Costa, Trung Q. Duong, Beongku An, "A BNBf User Selection Scheme for NOMA-Based Cooperative Relaying Systems With SWIPT", IEEE, 2016. In this letter, we investigate the outage performance of cooperative relaying transmissions in two-user non-orthogonal multiple access systems, wherein simultaneous wireless information and power transfer is employed at the near users to power their relaying operations. To this end, a best-near best-far (BNBF) user selection scheme is proposed. Considering three relaying protocols, i.e., decode-and-forward (DF), amplify-and-forward (AF), and hybrid DF/AF protocols, tight closed-form approximate expressions for the outage probability are derived to evaluate the system performance. Numerical results reveal that, for any relaying protocols used, the diversity order achieved by the BNBf scheme is  $M+1$ , where  $M$  is the number of far users, and does not depend on the number of near users.

[5] Xin Song, MingLei Zhang, WenMin Liu and Feng Liu, "Threshold-based hybrid relay selection scheme", IEEE, 2016. In this paper, in order to reduce error propagation for cooperative systems, we propose and analyze two new threshold-based hybrid relay selection schemes for the three-node cooperative relaying system, named as hybrid amplify-decode-forward relaying (HADf) and direct-amplify-forward relaying (HDf). When the signal-to-noise ratio (SNR) is higher than the specific threshold, which is designed in HDf, the relay chooses to transmit message in amplify-and-forward (AF) mode, otherwise, the source node deals with message in direct transmission (DT) mode without the relay. Similarly, in HADf scheme, a specific SNR threshold is derived to determine that the relay can choose to transmit message in decode-and-forward (DF) or AF mode. Closed-form expressions of the outage probability of the proposed HDf and HADf schemes are derived. Theoretical analysis and simulation results show that the HADf scheme outperforms the AF and DF schemes, and the HDf relaying scheme outperforms the DT and AF schemes.

However, compared with HDf scheme, the HADf scheme has a better outage probability in special channel condition.

[6] Ouadoudi Zytoune, Hacene Fouchal, Driss Aboutajdine, "A relay selection scheme for lifetime extension in amplify-and-forward cooperative networks" IEEE, 2017. Since more than a decade, wireless sensor networks is a very attractive field in computer science and networking. Battery management is a crucial issue in the area of wireless sensor networks. The communication between a source node and a destination one may fail if both nodes are located inside a deep shadow-fading zone. Relay-selection strategy has been used in order to extend amplify-and-forward (AF) cooperative networks lifetime. The communication could not be achieved if the signal-to-noise ratio (SNR) at the destination could not reach a reasonable threshold. In the literature, various relay selection schemes have been used under the assumption that batteries are linear, but their effectiveness is not guaranteed when realistic nonlinear battery models are considered. In this paper, we review some relay selection schemes with linear battery mode that were proposed to extend network lifetime. Then, a realistic nonlinear battery model is applied with these schemes. Through numerical studies, we give a performances comparison between these techniques. The results show that the maximum energy-efficiency index MEI and the minimum outage probability MOP schemes give the best network lifetime extension.

#### 4. APPLICATION

- Cooperative sensing for cognitive radio.
- Wireless Ad hoc Network.
- Wireless Sensor Network.
- Vehicle to Vehicle Communication.

#### 5. CONCLUSIONS

Hybrid relay selection on cooperative communication system is one type of protocol that select the relay use between relay AF and DF. Relay selection based on largest SNR value between AF and DF modes. Hybrid relay protocol on cooperative communication system process the best performance compare to direct AF, direct DF, multi-hop AF and multi-hop DF. Relay selection CC is an important task for achieving maximum capacity.

#### REFERENCES

- [1] T. Wing, A. Cano, and G.B. Giannakis, "Efficient demodulation in cooperative schemes using decode-and-forward relays," in Conf. Record 2005, Asilomar Conf. Signals, Syst. Comput. Pp 1051-1055.
- [2] K.R. Kumar and G. Caire, "Coding and decoding for the dynamic decode and forward relay protocol," in Proceedings of the IEEE International Symposium on Information Theory, pp. 2380-2384, 2008.

- [3] Trung Q. Duong and Hans-Jurgen Zepernick, "On the Performance Gain of Hybrid Decode-Amplify-Forward Cooperative Communications", EURASIP, 2009.
- [4] Yonghui Li, Raymond H.Y. Louie, Branka Vucetic, "Relay Selection With Network Coding in Two-Way Relay Channels", IEEE, 2010. Vol-59, Issue-9.
- [5] Tianxi Liu, Lingyang Song, Yonghui Li, Qiang Huo, Bingli Jiao, "Performance Analysis of Hybrid Relay Selection in Cooperative Wireless Systems" IEEE, 2012. Vol-60, Issue-3.
- [6] Xin Song, MingLei Zhang, WenMin Liu and Feng Liu, "Threshold-based hybrid relay selection scheme", IEEE, 2016.
- [7] Nhu Tri Do, Daniel Benevides DA Costa, Trung Q. Duong, Beongku An, "A BNBF User Selection Scheme for NOMA-Based Cooperative Relaying Systems With SWIPT" IEEE Communications Letters, 2016. Vol-21, Issue-3.
- [8] Ouadoudi Zytoune, Hacene Fouchal, Driss Aboutajdine, "A relay selection scheme for lifetime extension in amplify-and-forward cooperative networks" IEEE, 2017.