

A COMPUTATIONAL STUDY ON FRACTURE PROCESS ZONE FOR SINGLE EDGED NOTCHED BEAM SPECIMEN OF GEOPOLYMER CONCRETE

R. Aisswarya, B. Sivanandhini

Assistant Professor Veltech High Tech Engineering College, Chennai.
Assistant Professor, CK college of Engineering and Technology, Cuddalore.

Abstract— As the demand for concrete as a construction material increases, so only the demand for Portland cement. The production of cement is increasing about 3% annually. On the other hand, the climate change due to production of cement is also increasing causing global warming. So we have go for alternate materials which would be useful for replacement of cement as well as one which would have minimum adverse impact on environment. One such material is Geopolymer concrete. This Geopolymer concrete has good physical property compared to conventional concrete. Most important feature of Geopolymer use of cement is completely nullified hence very less adverse effect to environment. Failure of concrete due to fracture is one of the most dangerous and disastrous thing happening in concrete. Hence it is necessary to design concrete to withstand the failure due to fracture. The conventional designing technique does not take into account the flaws present in the component and assume the component is free from any flaws. This may not be correct all the times. These internal flaws may be the reason for initiation of cracks and failure of concrete or any other material. Hence it is necessary to design the components considering the internal flaws in the component. This current study attempts to study the fracture behavior of Geopolymer concrete computationally by giving an initial flaw. ABAQUS- FEM software was used to carry out the study on Geopolymer concrete. The fracture parameters were studied for different molarity of Geopolymer concrete 8 and 12 Molar Geopolymer concrete was used in this study. The initial flaw size was also varied from 0.05d to 0.2d. The results were obtained computationally.

Keywords- geopolymer, concrete, Portland cement

INTRODUCTION

As demand for concrete as a construction material increases the production of Portland cement also increases which in pollutes the environment there by causing global warming which is a alarming problem all over the world. This has raised the world to go for alternates for conventional concrete which would have the same properties of conventional concrete but on the other hand it should have less impact on the environment.

Geo Polymer Concrete:

Davidovits (1988) introduced the term 'Geopolymer' to represent the mineral polymer resulting

from geochemistry. Geopolymer, an alumina-silicate polymer, is synthesized from predominantly silicon (Si) and aluminum (Al) material of geological origin or by-product material.

Geopolymers are members of family of inorganic polymers. The chemical composition of Geopolymer materials is similar to zeolitic, but they reveal an amorphous microstructure. During the synthesized process, silicon and aluminium atoms are combined to form the building blocks that are chemically and structurally comparable to those binding the natural blocks.

Fracture Mechanics:

It is the branch of mechanics which deals with the propagation of cracks in structures subjected to loading. It provides a methodology of evaluating the structural integrity of components containing defects. The basic criterion in any fracture mechanics analysis is to prevent failure. The importance of this topic are the initiation of crack like defects during service life needs to be understood and quantified, the influence of pre-existing cracks on the strength of materials needs to be understood and quantified, a defect tolerant design and maintenance philosophy needs to be developed

Finite Element Analysis:

FEM is a numerical technique to solve field problems of complex geometries and boundary conditions. The fundamental concept of FEM is that any continuous field variable, such as velocity, stress, pressure or temperature can be approximated by a discrete model composed of a set of piecewise continuous field variables defined over a finite number of sub domains known as elements. These elements are interconnected at specified joints, which are called as nodes or nodal points. In computing SIF using FEM, a linear static analysis of the body with crack is carried out with or without special element around the crack tip.

FRACTURE PROCESS ZONE:

It is defined as the softening zone where the crack is going to propagate when the stress is being applied. In brittle materials, elastic energies are consumed in the form of surface energy with no fracture process zone. In the

ductile materials the FPZ is known as the plastic zone which can consume a considerable amount of energy, much more than the surface energy. For quasi-brittle material, a large FPZ which consumes a large amount of energy prior to failure is usually formed ahead of the crack tip.

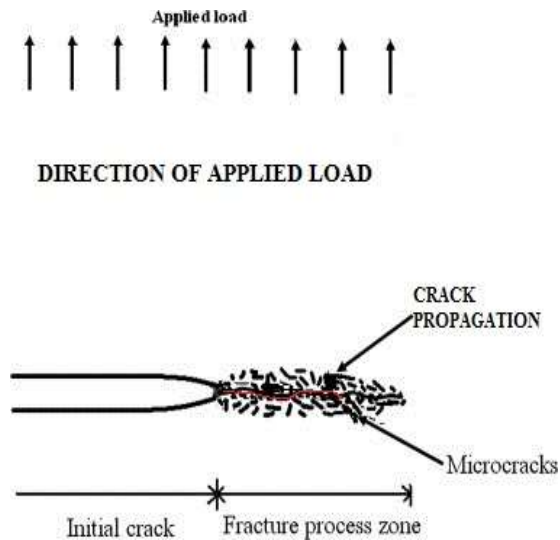

FINITE ELEMENT MODELLING

AIM OF INVESTIGATION

The main objective of the study is to evaluate the fracture properties of geopolymer concrete using FEM software. One of the fracture property being fracture process zone.

SCOPE OF THE STUDY

Studying the physical properties of geopolymer concrete without studying fracture behavior is off no use. Hence it is very much necessary to study the fracture behavior and fracture parameters of geopolymer concrete.

NEED FOR THE STUDY

- In major structures like nuclear power plant, dams, microscopic analysis of the concrete is important since even pre existing cracks can create major problem
- Even a small crack can propagate and become critical one during its life period that may lead to catastrophic failure.
- In concrete, flaws are not avoidable but the limitations shall be minimized so the limitations are determined by evaluation of fracture parameters.

FINITE ELEMENT MODEL

Abaqus - finite element software was used to model the geopolymer concrete and conventional concrete. The inputs for the models were obtained from past results and referring to journals.

Specimen details

- 4 Nos conventional M30 concrete beam of size 1200x200x100
- 4 Nos 12 molar Geopolymer concrete beam of size 1200x200x100
- 4 Nos 8 molar Geopolymer concrete beam of size 1200x200x100

Inputs for the models [4, 5]

Conventional concrete:

M30 concrete was used in the study

Compressive strength = 36.04 N/mm²

Young's modulus = 27386 N/mm²

Density = 2400 kg/m³

Poisson's ratio = 0.2

Geopolymer concrete - 12 molarity

Compressive strength = 43.11 N/mm²

Density = 2320 kg/m³

Poisson's ratio = 0.17

Young's modulus for geopolymer concrete was calculated using the formula

$$E_c = \rho^{1.5} * (0.024(f_{cm} + .12))^{0.5}$$

where ρ is the density of concrete in kg/m³

f_{cm} is the mean compressive strength in MPa

using above equation the value of young's modulus obtained was

Young's modulus = 32780 N/mm²

Geopolymer concrete - 8 molarity

Compressive strength = 41.4 N/mm²

Density = 2350 kg/m³

Poisson's ratio = 0.12

Young's modulus = 32015 N/mm²

Notch at the centre

A notch was given at the center of the models. The size of crack was varied from 0.05d to 0.2 d and different models were created. The crack sizes provided we 10, 20, 30 and 40 mm respectively. The crack was provided to study the fracture behavior of geopolymer concrete

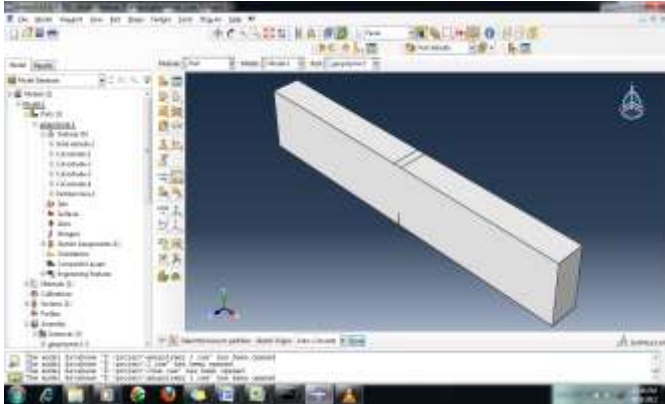

Beam model with a 40 mm crack at the centre

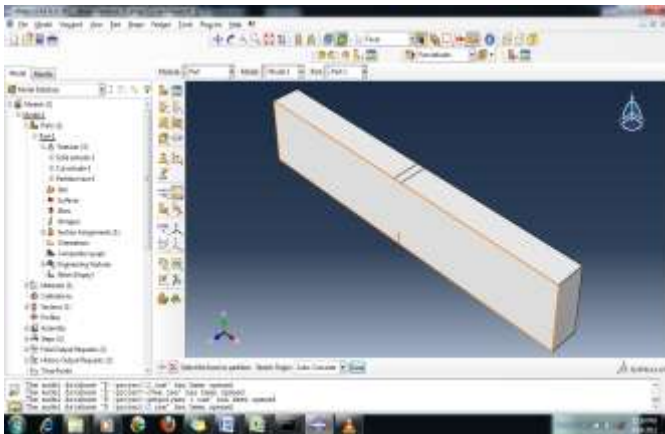

Beam model with a 30 mm crack at the centre

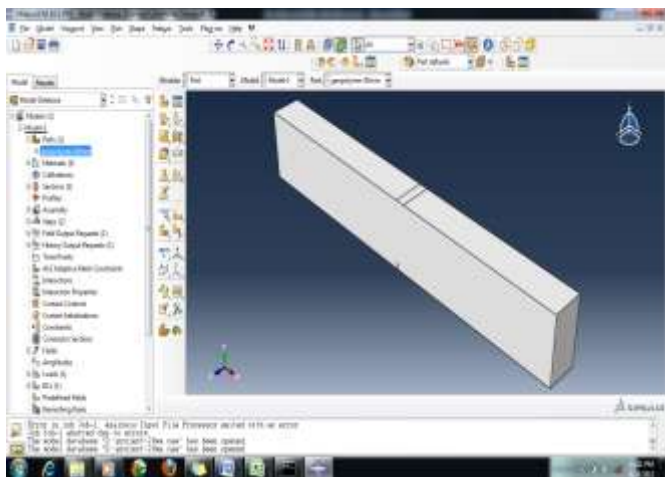

Beam model with a 20 mm crack at the centre

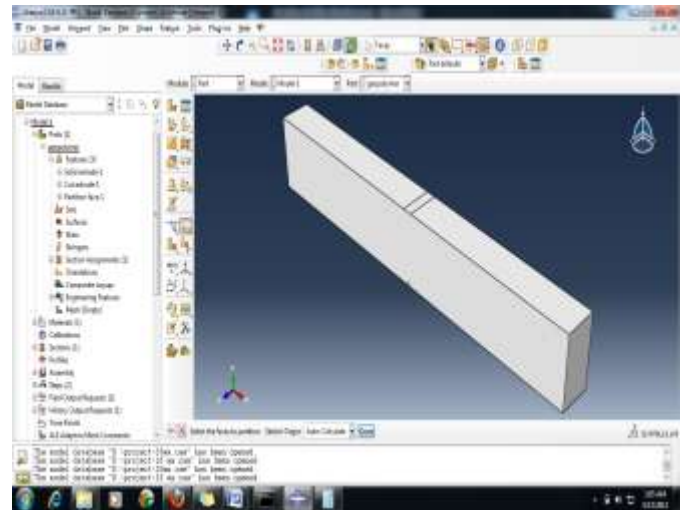

Beam model with a 10 mm crack at the centre

Loading

Three point loading was used in this study an area was created at the centre to simulate the loading in that of a loading frame. Loading was given in range of 0.5 kN and the beam was loaded till deflection crossed the permissible limit. The support was given at a clear span 1000mm

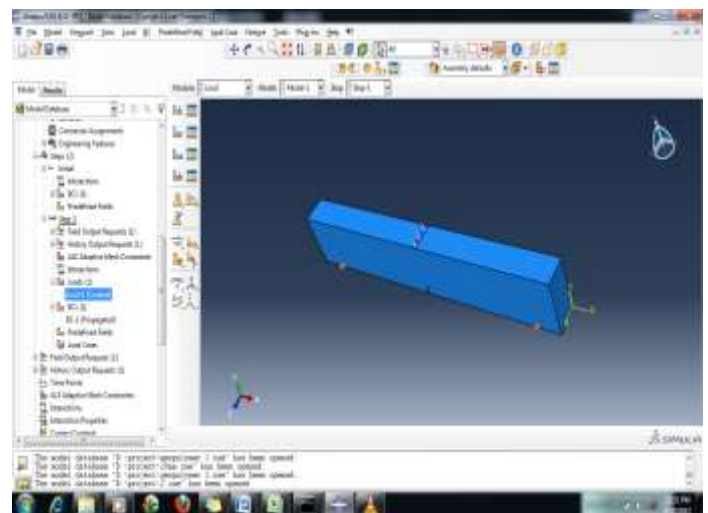

Three point loading applied to the beam

Meshing

Meshing has to be different in the crack region and all other places. A global mesh size of 1 and a 8 noded linear brick element at crack region and A global mesh size of 40 and a 4 noded tetrahedron element is used at all other regions.

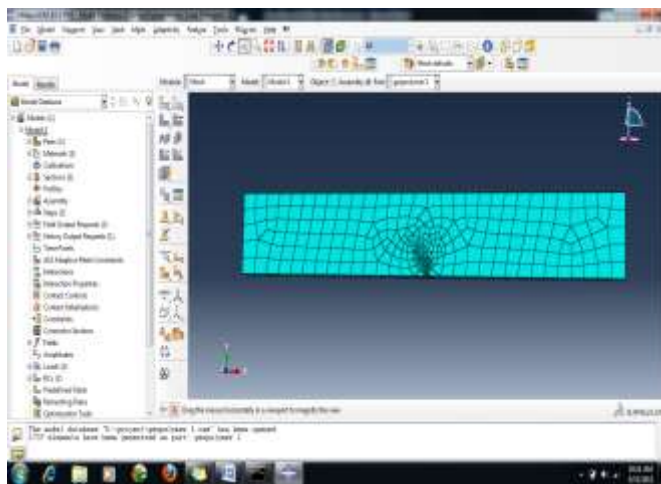

Meshing of the beam

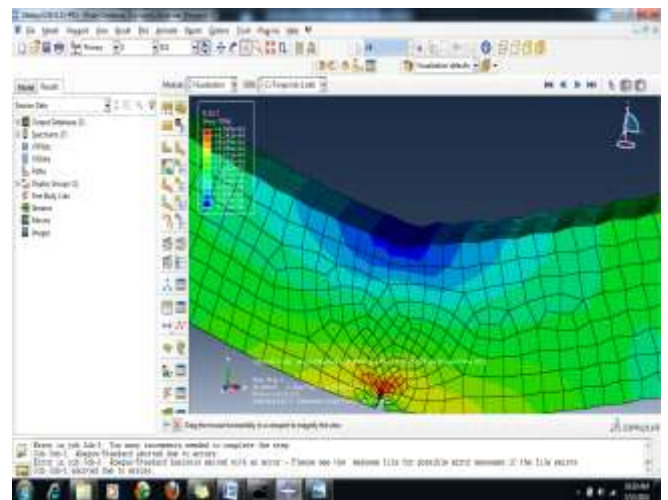

Fracture Process zone on the beam

Deflection

The maximum central deflection was found out for every 0.5 kN and readings were noted. The deflected model showed the crack started to open up and started to propagate as the load increased. The load vs deflection curve was drawn for each specimen.

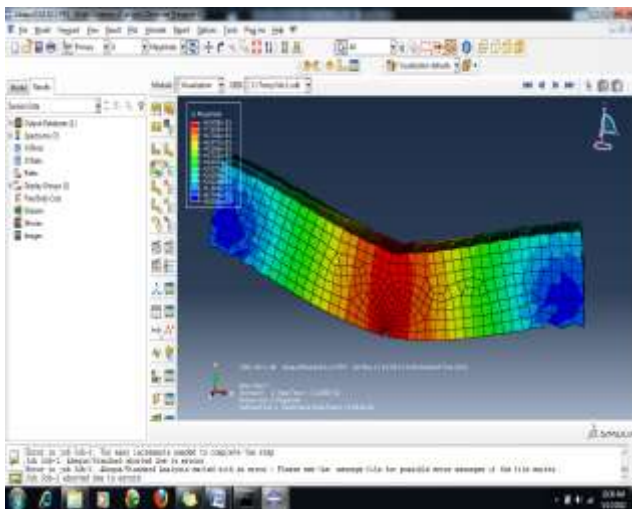

Deflected shape of the beam

Fracture process zone

The main objective of this study is the study of fracture process zone. From the FEM model the fracture process can be easily seen. The zone where the crack is going to propagate as the stress or load on the beam is increased.

I. RESULTS AND DISCUSSIONS

The load vs deflection was found out for each specimen was calculated and also found out for each crack size and are given in a tabulation form

Load vs Deflection values for crack

LOAD (kN)	DEFLECTI ON-CONTROL (mm)	DEFLECTION-GPC 12-M (mm)	DEFLECTION-GPC 8-M (mm)
0	0	0	0
0.5	0.4	0.63	0.54
1	0.81	0.82	1.029
1.5	1.22	1.44	1.54
2	1.62	1.93	2.05
2.5	2.03	2.25	2.5
3	2.75	2.852	3.08
3.5	3.56	3.56	3.6
4	4.06	4.65	4.11
4.5	4.6	5.72	4.675
5	5.07	6.362	5.14
5.5	5.58	7.59	5.65
6	6.09	8.2	6.38
6.5	6.5	9.11	8
7	7.1	10.62	9.47
7.5	7.93	11.81	11.8
8	8.68	12.73	12.7
8.5	9.52	14.5	15

Load vs deflection curves for crack size

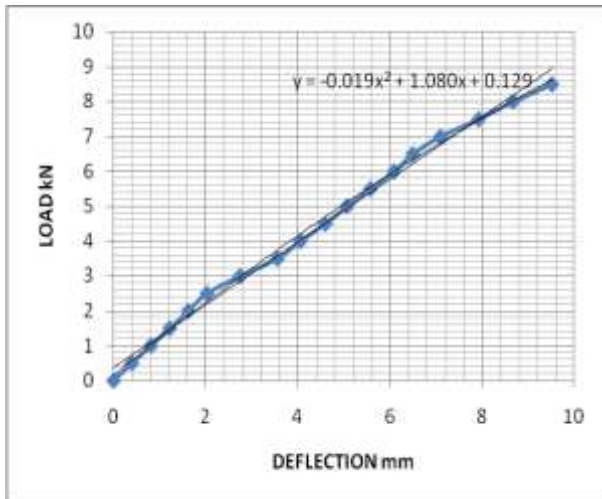

The tensile can be calculated using the following equation given by Australian

$$f_t = 0.4\sqrt{f_{cm}}$$

Where f_{cm} – mean compressive strength

Neville(2000) proposed another relation for finding tensile strength

$$f_t = 0.3(f_{cm})^{2/3}$$

Where f_{cm} – mean compressive strength

The results of fracture process zone analytically using the above two equation and experimentally are given below.

CONCLUSIONS

- Different fracture parameters have studied for normal concrete and geopolymer concrete.
- The fracture parameters of Geopolymer concrete have been compared with conventional concrete
- The fracture parameters studied were stress intensity factor k, critical J-integral, fracture energy and fracture process zone
- The fracture parameters have been studied by the molarity of Geopolymer concrete and also varying the notch to depth ratio from 0.05 to 0.2
- The stress intensity factor for Geopolymer concrete was higher when compared to that of normal conventional concrete with 12 molar Geopolymer concrete having the highest value.
- The K value of Geopolymer concrete was 20% more when compared to that of normal conventional concrete.
- The value of K decreases as the notch to depth ratio increases. Since more stress intensity is required for the crack to propagate when there is less flaw in the structure
- The values of J-integral for conventional were near t

Sl.No	Specimen	Stress intensity factor K_{Ic} Mpa \sqrt{m}
1	Control concrete	8.92
2	GPC 12 molarity	11.3
3	GPC 8 molarity	11.05

opolymer concrete with Geopolymer concrete of 12 molarity having a little higher value

- The analytical results were very near to that of experimental results.

Calculation of stress intensity factor (K)

Stress intensity factor one of the most important fracture parameter was calculated using the equation given below

Fracture process zone

For concrete, at normal temperature and loading rates, plastic deformation at the crack is negligible. However the inherent material heterogeneity gives rise to several other processes which cause considerable deviation from LEFM behavior. In other words, changing the scale of the microstructure and varying the relative contribution of

the various dissipative mechanisms, which are controlled mainly by the type of bonding and size, type and shape of the particles, will change the macroscopical fracture behaviour. For example, if we use a tough spherical particle together with a brittle bond, this will result in a fracture path only in the bond area. On the other hand, if the particles are more brittle than the bonds, this will result in a transgranular fracture. If the same particles have an elongated shape but the same bonding force the fracture process will also be altered. All these parameter change will influence the acrosopical fracture behaviour and the length of the process zone.

For a quasi-brittle material the fracture process zone can be calculated using the following relation [3]

$$\rho = EG \div f_t^2$$

Where, E is the Young's modulus,

G is the fracture energy, and

Ft is the tensile strength

- Fracture energy should the same trend but the value of fracture energy Geopolymer concrete was much higher than that of conventional concrete.
- The fracture energy of 8 molar Geopolymer concrete was 80 % more than that of the normal concrete and 12 molar Geopolymer concrete showed nearly 90% increase in fracture energy value when compared to that of normal concrete.
- The value of fracture energy decreased as the notch to depth ratio was increased since more energy is required for the crack to propagate when there is less flaws in the structure.
- The analytical results showed a great agreement with the experimental results.
- The main fracture parameter of this study fracture process zone showed opposite trend of the above two. The normal concrete showed higher value than that geopolymer concrete.
- The reason is normal concrete is denser than that of the Geopolymer concrete.
- The fracture process value of normal concrete was nearly 30% than 8 molar Geopolymer concrete and 25 % more than 12 molar Geopolymer concrete

Based Geopolymer Concrete". Developments in Mechanics of Structures and Materials,

7. Ing. Václav Veselý (2008) "Methods For The Determination Of Fracture-Mechanical Parameters Of Concrete – Cohesive Crack Models
8. N A Lloyd and B V Rangan (2010) "Geopolymer concrete with fly ash" proceedings of the second international conference on sustainable materials and construction
9. Roylance (2001) "Introduction to Fracture Mechanics" Department of Materials Science and Engineering
10. SARKER (2008) "A CONSTITUTIVE MODEL FOR FLY ASH-BASED GEOPOLYMER CONCRETE"
11. F.J. Silva and C. Thaumaturgo (2006) "The Chemistry, Reinforcement And Fracture In Geopolymeric Cement Composites"
12. Tushar Kanti Mandal (2005) "STUDY ON THE STRENGTH OF FLY ASH BASED GEOPOLYMER CONCRETE"
13. F H Wittmann (2002) "Crack formation and fracture energy of normal and high strength concrete" Sadhana Vol. 27, Part 4, August 2002, pp. 413-423
14. D. A. Zacharopoulos (2008) " Mixed-Mode Crack Growth And Path In Three Point Bending Cracked Specimen"

REFERENCES

1. M. Al-Mukhtar , S. Henkel , H. Biermann , P.Hübner (2009)" A Finite Element Calculation of Stress Intensity Factors of Cruciform and Butt Welded Joints for Some Geometrical Parameters" Jordan Journal of Mechanical and Industrial Engineering Volume 3, Number 4, December 2009 ISSN 1995-6665 Pages 236 - 245
2. Dylmar Penteado Dias, Clelio Thaumaturgo (2004) "Fracture toughness of geopolymeric concretes reinforced with basalt fibers" Cement & Concrete Composites 27 (2005) 49-54
3. Emilio Jiménez Piqué (2002) "Fracture process zone of quasi brittle materials: a model material approach" ISBN 90-386-2793-9
4. D. Hardjito and B. V. Rangan(2005) "Research Report" GC 1 Faculty of Engineering Curtin University of Technology Perth, Australia
5. Hardjito, D., and Rangan (2005), B.V.; "Development and Properties of Low Calcium Fly Ash-Based Geopolymer Concrete". Research Report GC1, Faculty of Engineering, Curtin University of Technology, Western Australia,
6. Hardjito, D., Wallah, S. E., Sumajouw, M. J., and Rangan, B. V.; "The Stress-Strain Behaviour of Fly Ash-