

Design and analysis of Single ended primary inductance Converter (SEPIC) for Battery Operated devices using MATLAB Simulation

Poonam Verma¹, Dr. M. K. Bhaskar², Chetna Chhangani³, Manish Parihar⁴

^{1,3}ME Scholar, Electrical Department, MBM Engineering college, Jodhpur, INDIA

²Professor, Electrical Department, MBM Engineering college, Jodhpur, INDIA

⁴Phd Scholar, Electrical Department, MBM Engineering college, Jodhpur, INDIA

Abstract: - In present scenario, different portable electronic devices are implemented with dc-dc converters, that are able to gain high efficiency with a wide input and output ranges with smaller sizes. But the conventional converters can't maintain the specified criterion, especially if up and down voltage has to be achieved. This can be obtained by SEPIC Converter. The SEPIC-voltage regulator is a good choice for non-isolated battery-powered systems. The topology is able to both buck and boost the voltage, and unlike a conventional buck/boost regulator, supply a non-inverted- and zero-volt output. Due to this the input current example of the SEPIC is smooth (because of the inductor) and the output current signal is chopped (because of the diode feeding the output) then the energy is passed across the capacitors are widely used because of its very high efficiency in PC power supplies, battery chargers DC motor power systems and different industrial applications.

Key Words: SEPIC converter, Efficiency, Regulator

1. INTRODUCTION

The single-ended primary-inductance converter (SEPIC) is a DC/DC-converter topology that provides a positive regulated output voltage from an input voltage that varies from above to below the output voltage. This type of conversion is handy when the designer uses voltages (e.g., 12 V) from an unregulated input power supply such as a low-cost wall wart. Unfortunately, the SEPIC topology is difficult to understand and requires two inductors, making the power-supply footprint quite large. Recently, several inductor manufacturers began selling off-the-shelf coupled inductors in a single package at a cost only slightly higher than that of the comparable single inductor. The coupled inductor not only provides a smaller footprint but also, to get the same inductor ripple current, requires only half the inductance required for a SEPIC with two separate inductors. This article explains how to design a SEPIC converter with a coupled inductor.

Circuits run best with a steady and specific input. Controlling the input to specific sub circuits is crucial for fulfilling design requirements. AC-AC conversion can be easily done with a transformer; however dc-dc conversion is not as simple. Diodes and voltage bridges are useful for reducing voltage by a set amount, but can be inefficient. Voltage regulators can be used to provide a reference voltage. Additionally, battery voltage decreases as batteries discharge which can cause many problems if there is no voltage control. The most

efficient method of regulating voltage through a circuit is with a dc-dc converter. There are 5 main types of dc-dc converters. Buck converters can only reduce voltage, boost converters can only increase voltage, and buck-boost, Cúk, and SEPIC converters can increase or decrease the voltage. Some applications of converters only need to buck or boost the voltage and can simply use the corresponding converters. However, sometimes the desired output voltage will be in the range of input voltage. When this is the case, it is usually best to use a converter that can decrease or increase the voltage. Buck-boost converters can be cheaper because they only require a single inductor and a capacitor. However, these converters suffer from a high amount of input current ripple. This ripple can create harmonics; in many applications these harmonics necessitate using a large capacitor or an LC filter. This often makes the buck-boost expensive or inefficient. Another issue that can complicate the usage of buck-boost converters is the fact that they invert the voltage. Cúk converters solve both of these problems by using an extra capacitor and inductor. However, both Cúk and buck-boost converter operation cause large amounts of electrical stress on the components, this can result in device failure or overheating. SEPIC converters solve both of these problems [1][3].

1.1 Design of SEPIC Converter

The purpose of this paper is to design and optimize a SEPIC dc/dc converter (Single Ended Primary Inductance Converter). The SEPIC converter allows a range of dc voltage to be adjusted to maintain a constant voltage output. This paper describes about the importance of dc-dc converters and why SEPIC converters are used instead of other dc-dc converters. All dc-dc converters operate by rapidly turning on and off a MOSFET, generally with a high frequency pulse. What the converter does as a result of this is what makes the SEPIC converter superior. For the SEPIC, when the pulse is high/the MOSFET is on, inductor 1 is charged by the input voltage and inductor 2 is charged by capacitor 1. The diode is off and the output is maintained by capacitor 2. When the pulse is low/the MOSFET is off, the inductors output through the diode to the load and the capacitors are charged.

The greater the percentage of time (duty cycle) the pulse is low, the greater the output will be.

This is because the longer the inductors charge, the greater their voltage will be. However, if the pulse lasts too long, the

capacitors will not be able to charge and the converter will fail.

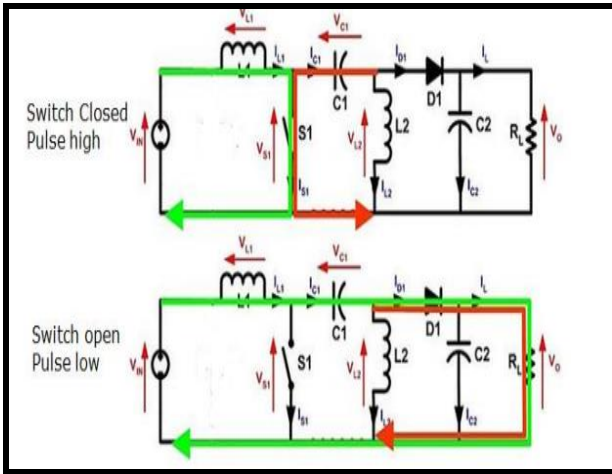

Fig -1: SEPIC operation

Using a coupled inductor takes up less space on the PCB and tends to be lower cost than two separate inductors. The capacitor Cs isolates the input from the output and provides protection against a shorted load. Both figures Show the SEPIC converter current flow and switching waveforms[2][3].

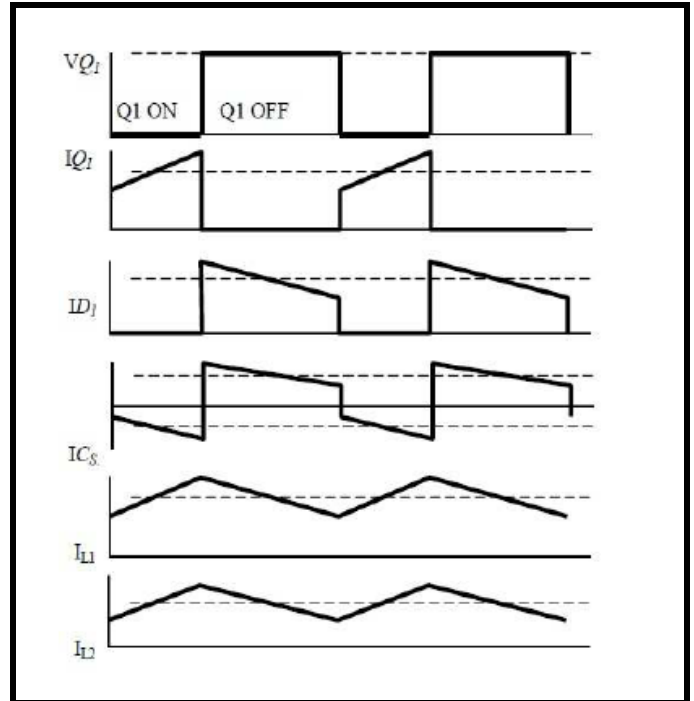

Fig-3: SEPIC Converter Switching Waveforms

1.2 Duty Cycle Consideration

For a SEPIC converter operating in a continuous conduction mode (CCM), the duty cycle is given by V_D is the forward voltage drop of the diode D1.

The amount that the SEPIC converters step up or down the voltage depends primarily on the Duty Cycle and the parasitic elements in the circuit.

The output of an ideal SEPIC converter is

$$V_o = \frac{D * V_i}{1 - D} \quad \dots (1)$$

However, this does not account for losses due to parasitic elements such as the diode drop V_D . These make the equation:

$$V_o + V_D = \frac{D * V_D}{1 - D} \quad \dots (2)$$

This becomes

$$D = \frac{V_o + V_D}{V_i + V_D + V_o} \quad \dots (3)$$

The maximum Duty Cycle will occur when the input voltage is at the minimum.

If $V_D = .5V$, the Duty Cycle is

$$D_{min} = \frac{10V + 0.5V}{6V + 10V + 0.5V} \approx 0.64 \quad \dots (4)$$

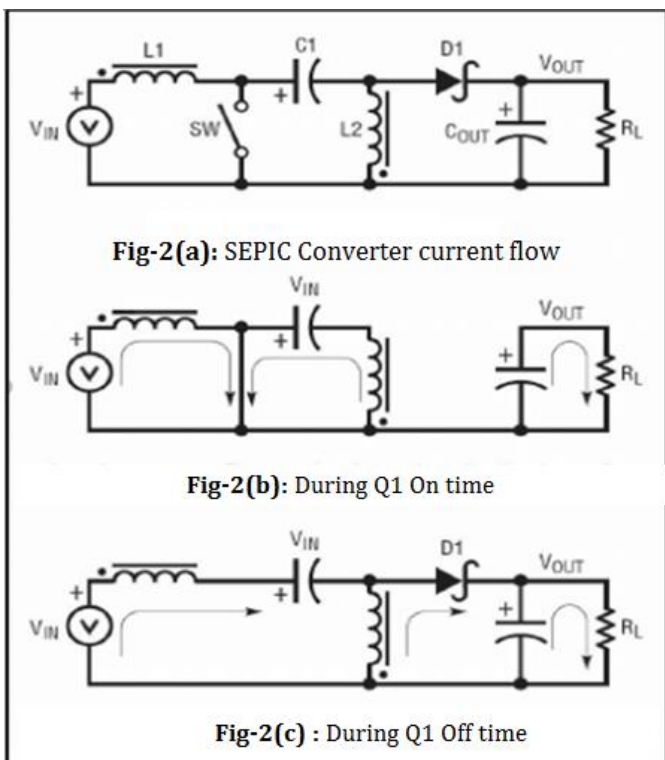

Fig-2: (a) SEPIC Converter Current Flow

(b) During Q1 On-Time

(c) During Q1 Off-Time

The minimum duty cycle will occur when the input voltage is at the maximum

$$D_{min} = \frac{10V + 0.5V}{18V + 10V + 0.5V} \approx 0.37 \quad \dots (5)$$

1.3 Inductor Selection

A good rule for determining the inductance is to allow the peak-to-peak ripple current to be approximately 40% of the maximum input current at the minimum input voltage [4].

The ripple current flowing in equal value inductors L1 and L2 is given by:

$$I_L = I_{IN} * 40\% = I_{OUT} \frac{V_{OUT}}{V_{IN(MIN)}} * 40\% \quad \dots (6)$$

The inductor value is calculated by:

$$L1 = L2 = L = \frac{V_{IN(MIN)} * D_{MAX}}{I_{L(MAX)} * f_{SW}} \quad \dots (7)$$

In theory, the larger the inductors are the better the circuit will operate and reduce the ripple.

However, larger inductors are more expensive and have a larger internal resistance.

This greater internal resistance will make the converter less efficient [5][6].

Creating the best converter requires choosing inductors that are just large enough to keep the voltage and current ripple at an acceptable amount.

2. Simulation and Analysis of SEPIC converter

2.1 Simulink Model

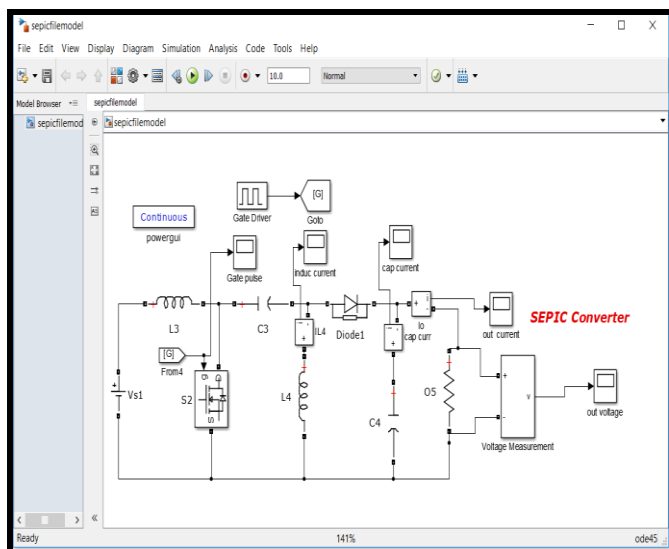

Fig 4: Simulink model for SEPIC Converter

2.2 Performance Analysis of Sepic Converter Parameters

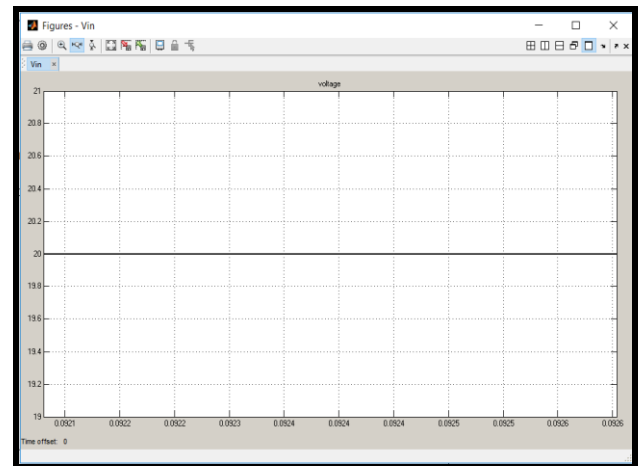

Fig 5: Input voltage of SEPIC Converter

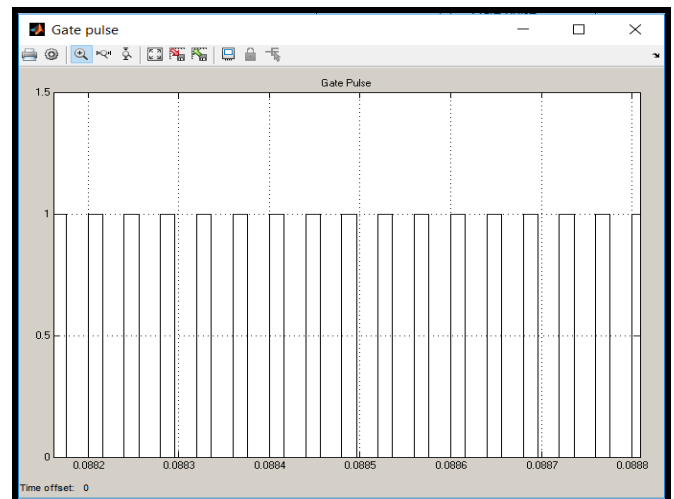

Fig 6: Gate Pulses supplied in MOSFET

Fig 5 and Fig 6 show the input voltage of the converter that is taken as 20 Volt and Gate pulse of 1 volt amplitude and 40 pulse width (% of period).

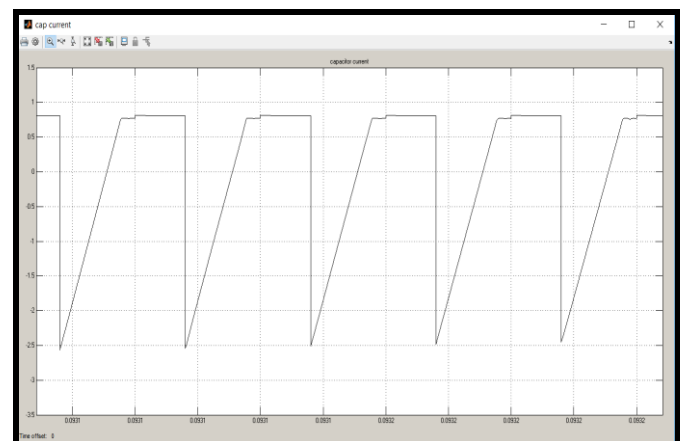

Fig 7: Current waveform of Capacitor C4

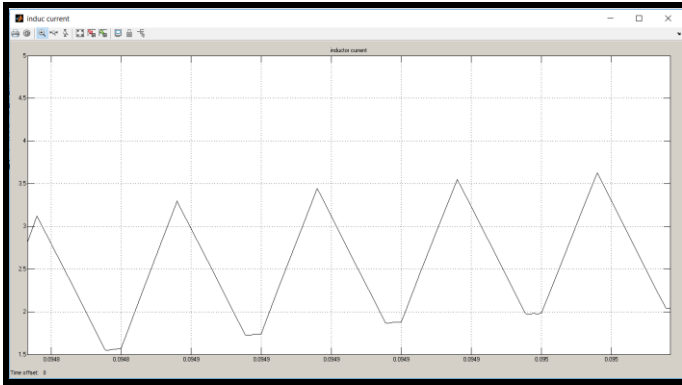

Fig 8 : Current waveform of inductor L4

Fig (7-8) shows the current waveforms of capacitor C4 and inductor L4 for SEPIC converter with duty cycle of 0.44.

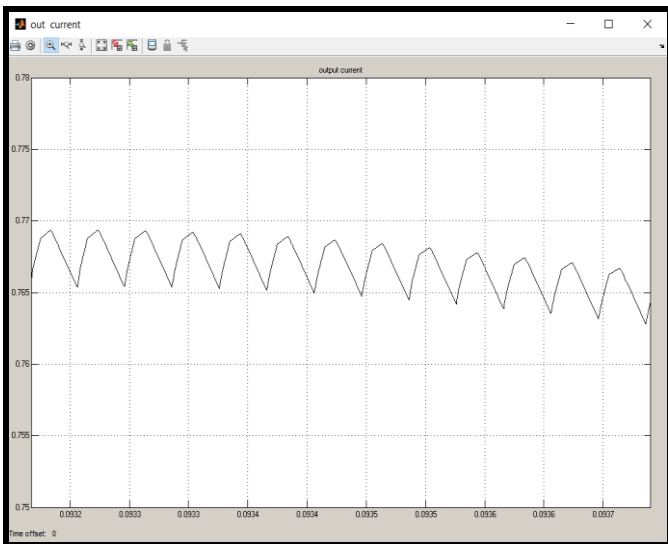

Fig 9: Output current waveform of SEPIC Converter

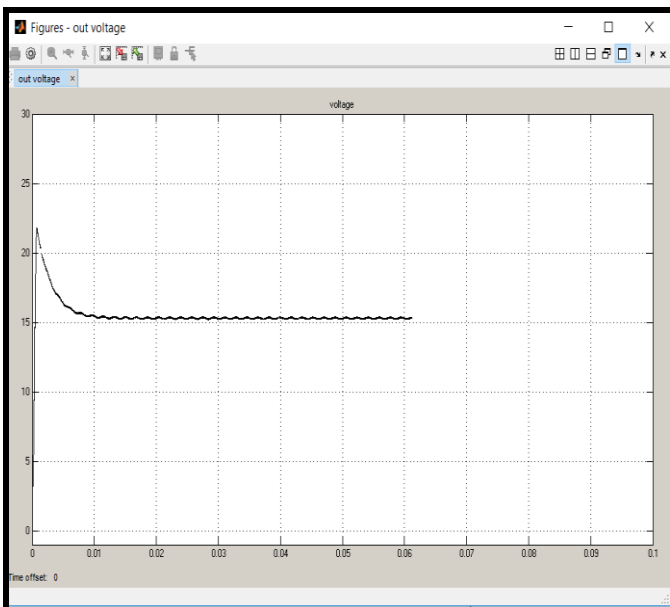

Fig 10: Output Voltage waveform of SEPIC Converter

Fig 9 shows the output current waveform of SEPIC converter and the magnitude is 0.76A. and By performing simulation with the help of MATLAB 13 Fig 10 shows the output voltage waveform of SEPIC converter. Output voltage across resistive load is 15.32 Volt for input of 20 volt.

2.3 SEPIC Converter parameters

CASE I : When input is constant $V_i=20$ Volt

Table -1: SEPIC Converter Performance parameters

Parameters	SEPIC
Output (Vdc)	15.32Volt
Input voltage (Vin)	20Volt
Output current (Idc)	0.766 A
Output power (Pdc)	11.73512 Watt
Voltage Gain	0.766
Efficiency	76.6 %
Power Loss	48.26488 Watt

CASE II : When input is variable

Table -2 : Output voltage with variance in input voltage

Input Voltage (Volt)	Output voltage(Volt)
10	7.466
20	15.32
30	23.17
40	31.08
50	38.91
60	46.77
70	54.62

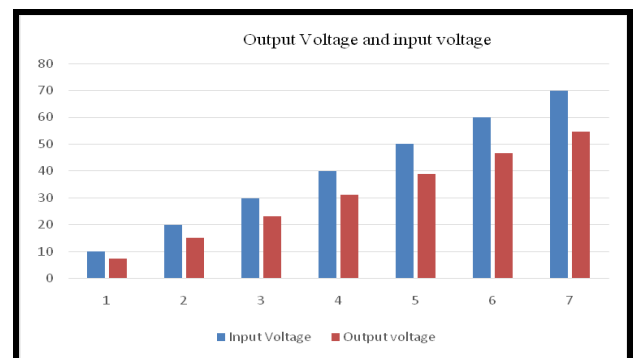

Fig 11: Determination of output voltage curve with the variation in input voltage

Fig 11 shows the decrement in the output voltage according to the input voltage.

Case III: When input current and voltage is varied

Table 3: Output power with variance in input power

Input Voltage (Volt)	Input current (A)	Input Power (Watt)	Output power (Watt)
10	1A	10	7.466
20	2A	40	30.64
30	3A	90	69.51
40	4A	160	124.32
50	5A	250	194.55
60	6A	360	280.62
70	7A	490	382.34

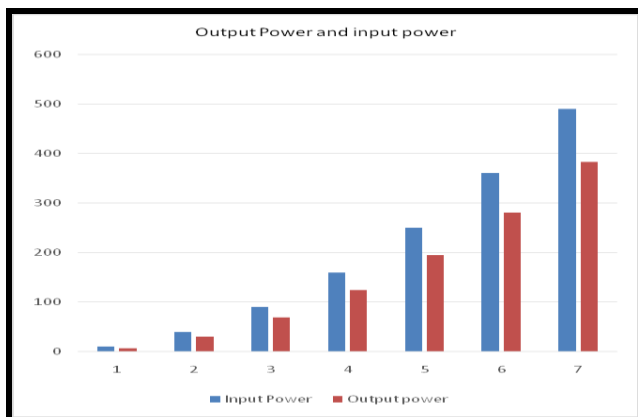

Fig-12 : Determination of output power curve with the variation in input voltage and current

Case IV: When input power is varied and efficiency is determined

Table 4 : Efficiency with variance in input power

Input Voltage (Volt)	Input current (A)	Input Power (Watt)	Efficiency (%)
10	1A	10	74.66
20	2A	40	76.6
30	3A	90	77.23333
40	4A	160	77.7
50	5A	250	77.82
60	6A	360	77.95
70	7A	490	78.028517

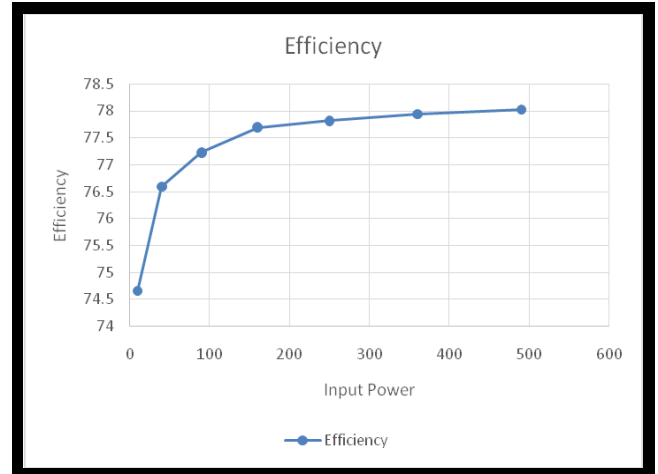

Fig-13 : Determination of Efficiency curve with the variation in input

3. CONCLUSIONS

Modeling of SEPIC Converter has been selected to generate a step down DC voltage, as 20volt input is supplied and 15.32 volt is obtained with the result of simulation. This type of converter can be used in battery operated devices, where low voltage is required. Graphical comparison is done by varying the input parameters and the corresponding output parameters are obtained. All the specification and values of passive components for designing of a SEPIC converter is determined. By using MATLAB Simulink, analysis and simulation of SEPIC Converter has been carried out. MATLAB simulation using calculated parameters is performed and corresponding waveforms are obtained. From simulation it is observed that output voltage is dependent upon the duty cycle.

REFERENCES

- [1] Falin, Jeff. "Designing DC/DC Converters Based on SEPIC Topology." Analog Instrumentation Journal. Texas Instruments. Web. 12 Jan. 2016.
- [2] James Dunia, Bakari. "Performance Comparison between CUK and SEPIC Converts for Maximum Power Point TRacking Using Incremental Conductance Technique in Solar Power Applications." International Journal of Electrical, Electronics and Communications Engineering 7.12 (2013)
- [3] Maglin, J.R, R. Ramesh, and Vaigundamoorthi. "Design and Analysis of SEPIC Converter Based MPPT for Solar PV Module with CPWM." J Electr Eng Technol 9.4 (2014).
- [4] Naithani, Vivek, Madan Mohan Malaviya, and Govind Ballah. "Simulation Of SEPIC Converter FED LEOs." International Journal of Engineering Science and Technology 4.3 (2012).

- [5] Raj, T. Ajith Bosco, J.R Maglin, M. Vaigunda moorthi, and William Christopher. "Grid Connected Solar PV System with SEPIC Converter Compared with Parallel Boost Converter Based MPPT." International Journal of Photo energy (2014).
- [6] Kashyap, A.R.; Ahmadi, R.; Kimball, J.W. "Input voltage control of SEPIC for maximum power point tracking", IEEE Power and Energy Conference at Illinois (PECI), Page(s): 30 - 35, 2013.
- [7] Azadeh Safari and Saad Mekhilef, "Simulation and Hardware Implementation of Incremental Conductance MPPT With Direct Control Method Using Cuk Converter", IEEE transactions on industrial electronics, vol. 58, no. 4, April 2011, pp. 1154-1161
- [8] Hong li,zhong li, Bo Zhang, Fenglan Wang, Nanlin Tan and wolfgang A.Halang, "Design of analogue chaotic PWM for EMI suppression" IEEE transactions on electromagnetic compatibility, Vol. 52, No. 4, November 2010.
- [9] Li,H., Tang, W.K.S., Li,Z., and Halang,W.A., "A chaotic peak current mode boost converter for EMI reduction and ripple suppression", IEEE transactions on circuits and system.

AUTHORS



Poonam Verma was born in Rajasthan India. She completed her B.Tech in Electronics & Communication Engineering JECRC, Rajasthan. In 2017, M.E.(Control Systems) from MBM Engineering College, Jodhpur. She had worked as Assistant Professor in JIET Engineering College, Jodhpur, Rajasthan.



Dr. M.K. Bhaskar received B.E. from Malviya Regional Engineering College (MREC) known as MNIT, Jaipur and he completed his master of engineering and PhD. from M.B.M. engineering. College. He is currently working as a Professor in Electrical Engineering, M.B.M.Engineering College, JNVU Jodhpur, Rajasthan.