

Bit Error Rate (BER) Performance Evaluation of Reference Channel for Power Line Communication (PLC) Channel under Multipath Modeling Technique

Shubham Pandey¹

¹MTECH, NITTTTR, Bhopal, India

Abstract - Power Line Communication (PLC) is a substitute to wireless communication for providing high-speed broadband multimedia services within the office or home with the advantage of abolishing the requirement for additional power cables and reducing the communication infrastructure cost. The development of power line communication requires sufficient information of the PLC physical properties and characteristics in order to choose suitable transmission methods. This paper presents analysis of Multipath technique which is based on Time Domain Modeling technique [3]. In order to evaluate the performance of PLC, this thesis simulates practical multipath PLC channel model on the basis of reference channels and provides the Bit-Error-Rate (BER) vs. Signal-to-Noise Ratio (SNR) curves for Orthogonal Frequency Division Multiplexing (OFDM). Hence by comparing the BER of the data transmitted through these reference channels, a practical reference channel is proposed forward which can be used effectively for Power Line.

Key Words: Power Line Carrier Communication (PLCC), Transmission Line Model, Multipath Channel Model, Reference Channels, OFDM, BER

1. INTRODUCTION

Among those communication technologies, Power Line Communication (PLC) is getting a tremendous amount of research interest. The advantage is that there is no requirement for new infrastructure, which is both tedious and costly to introduce. PLC utilizes the in building electrical wiring as a local area network over IP and home entertainment service at power socket in home or business premises. The most important elements that influence communications over electrical cables are attenuation, multipath fading, and noise, which increases with the increase in channel length, thus limiting the long distance communication.

One more inconvenience is that the data signal infused to PLC could not go through the transformer. So there is a need of bypass devices across the transformer which increases complexity and cost. From past decades, PLC is used for electrical signal transmission and distribution, But till now, communication capacities of power line cable are restricted. Now there is a need for communication capabilities is remote metering and operation management.

Since late 1980's, a lot of research is being done in the field of PLC because of its various advantages. The power cables

exist all over, therefore PLC makes the internet accessible from each room through every socket. Security is one of the major issues in any telecommunication system. But in a case of shared medium like power line channel, its effect is significantly large, However in PLC the physical medium is difficult to get retrieved so, it is more secure channel compared to the wireless network. There are various applications of Power Line Communication such as Automatic Meter Reading (AMR), Home Automation, Demand Side Management (DSM), Vehicle to Grid Communication in electric vehicles and many more.

This paper is divided into four topics. In first topic, introduction regarding power line, it's advantage disadvantage is provided. Then in the methodology, Multipath Model is discussed and it's transfer function is derived on the basis of our experimental analysis. Moving forward OFDM technique is discussed in brief.

Then the schematic representation and BER calculation are explained. In the third the Bit Error Rate (BER) performance evaluation of the PLC using BPSK-OFDM and QPSK-OFDM under multipath effect using two reference channels which are derived from multipath model has been done through the simulations in the MATLAB. Then at last the conclusions of this present work is drawn.

2. METHODOLOGY USED:

A power line channel model is represented to show the attenuation and delay over the transmitted signals. A power line medium is characterized by Impedance discontinuities and various branches. Due to this, the transmitted signals in the power line cables go through several reflections that bring a multipath effect.

Thus a power line cables can be well modeled by using Multipath Model. In Multipath Model [2], the propagation of signals does not takes place only between transmitter and receiver, but other paths are also considered. Let, X is the point of transmission and Z is the point of reception.

The channel has a branch at point Y. The branch ends at point W. The cable lengths are d_1, d_2 and d_3 and characteristic impedances are Z_1, Z_2 and Z_3 . Reflection coefficients are Γ_1, Γ_2 and Γ_3 and T_{XY} and T_{WY} are transmission parameters.

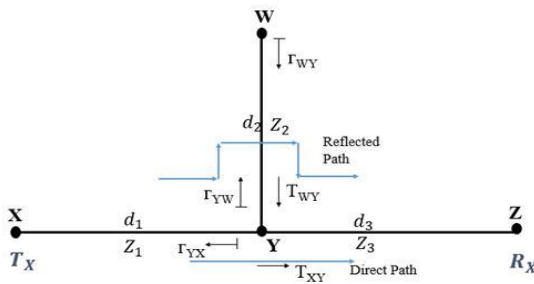

Fig - 1: Power Line Cable Topology

There are two possibilities for the signal is transmitted from X to Z. The initial one is an immediate way from X over Y to Z. Second way is X → Y → W → Y → Z. Refection of signals appears at point W. Except direct path all other signal experience numerous reflections at W before reaching Z. With these assumptions, an infinite number of propagation paths are possible in principle, because of numerous reflections. Every path has weighing factor g_i which is the product of reflection coefficient and transmission coefficient along the path. All refection and transmission coefficients are always less than or equal to 1. Consequently the weighing factor g_i , a result of multiplication of transmission and reflection coefficient along the path, is also less or equivalent to one i.e.

$$|g_i| \leq 1$$

Also each path experience different delay τ_i defined as

$$\tau_i = \frac{d_i \sqrt{\epsilon_r}}{c_0} = \frac{d_i}{v_p}$$

Where,

d_i is the length of path,

c_0 is the speed of light

ϵ_r is dielectric constant of insulating material.

From this topology only N dominant path considered for analyzing power line channel.

The formulas for all reflection and transmission coefficients along the paths are following

- Reflection Coefficients

$$\Gamma_{YX} = \frac{Z_{Y23} - Z_1}{Z_{Y23} + Z_1}$$

$$\Gamma_{VW} = \frac{Z_{V13} - Z_2}{Z_{V13} + Z_2}$$

$$\Gamma_{WV} = \frac{Z_W - Z_2}{Z_W + Z_2}$$

- Transmission Coefficients

$$T_{WV} = \frac{2Z_{V13}}{Z_{V13} + Z_2}$$

$$T_{XV} = \frac{2Z_{V23}}{Z_{V23} + Z_2}$$

Where,

$$Z_{X13} = \frac{Z_1 Z_3}{Z_1 + Z_3}$$

$$Z_{Y23} = \frac{Z_2 Z_3}{Z_2 + Z_3}$$

Table 1: Multipath in PLC Topology

Possible Path (i)	Signal Propagating Nodes	Reflection Factor (g_i)	Propagation Length (d_i)
1	X→Y→Z	T_{XY}	$I_1 + I_2$
2	X→Y→W→Y→Z	$T_{XY} \Gamma_{WY} T_{WY}$	$I_1 + 2I_2 + I_3$
3	X→(Y→W→Y) ² →Z	$T_{XY} \Gamma_{WY}^2 \Gamma_{YW} T_{WY}$	$I_1 + 4I_2 + I_3$
⋮	⋮	⋮	⋮
N	X→(Y→W→Y) ^{N-1} →Z	$T_{XY} \Gamma_{WY}^{N-1} \Gamma_{YW}^{N-2} T_{WY}$	$I_1 + 2(N-1)I_2 + I_3$

In this Table, all the N possible paths are listed along with their respective reflection factors (g_i) and length of propagation (d_i)

2.1. PLC Channel Transfer Function on the basis on Multipath Model

The transmitted signals are affected by attenuation A(f,d) that is increased with length and frequency. The signals from the all individual paths have to be combined by using superposition principle. Therefore, the frequency response H(f) from X to Z can be expressed as:

$$H(f) = \sum_{i=1}^N g_i e^{-(\alpha_0 + \alpha_1 f^k)} \cdot e^{-j2\pi f \cdot (d_i/v_p)}$$

Where

g_i : weighing factor

$e^{-(\alpha_0 + \alpha_1 f^k) d_i}$: Attenuation Portion

$e^{-j2\pi f(d_i/v_p)}$: Delay Portion

Following table describes the parameters included in the transfer function:

Table 2: Description of the Parameters of the Transfer Function

Parameters	Description
I	Number of paths, where the path with shortest delay has index i=1
α_0, α_1	Attenuation (cable) parameters
K	Exponent factor of attenuation (theoretically between 0.5 to 1)
g_i	Weighing factor
d_i	Length of each link i
τ_i	Delay of each link i
N	Number of dominant paths

2.2. Power Line Reference Channels (RC)

Every communication link exhibits its restrictive unique profile, because of individual system structure, dominant effects of signal propagation and an individual noise spectrum. In any case, the link can be assigned to groups depending on length, type of cable and number of branches. To every group a normal reference channel is assigned. In this chapter, four reference channels [1] are proposed which are based on Multipath Model. The figures below represent silent characteristics of the reference channels, observed in various estimations. The reference channels might be utilized directly for the evaluation of channel characteristics, for system rating and for standardization. Here we are showing the Frequency Responses of these Reference Channels.

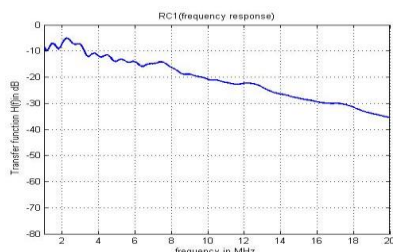

Fig - 2: Frequency Response of Reference Channel 1

RC1 is a representation of a decent power line station. It depends on a link at a length of roughly 100m – without branches. This kind of link acquires just a few reflection

points. In residential areas with equidistant column houses and house interfering cables of comparable length. The frequency response may show deep notches.

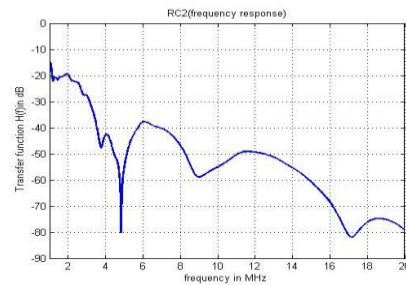

Fig - 3: Frequency Response of Reference Channel 2

RC2 is a type of link, which has a length of 110 m – with 6 branches. With extending length, this regular network structure may bring abrupt frequency response along with deep fading.

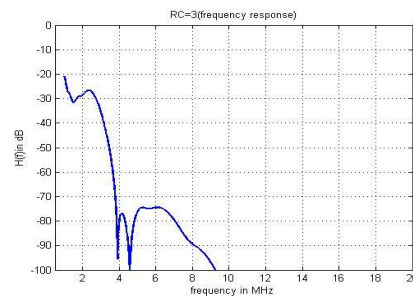

Fig - 4: Frequency Response of Reference Channel 3

RC3 is a type of link that relates to a network having length of 210m – with 8 branches. This link demonstrates an exceptionally abrupt fading with increase of attenuation.

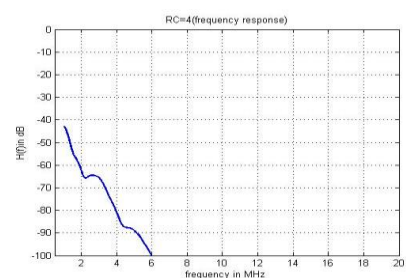

Fig - 5: Frequency Response of Reference Channel 4

RC4 is a type of link which is typically found in residential areas without significant general system structure. Because of various branches this link exhibits a large attenuation.

The database of these reference channels are considered from the European 3-phase underground distribution system using PVC isolated cables. These Reference Channels are summarized [6] as follows:

- RC 1: excellent channel, length 100m, with zero branch

- RC2: good channel, length 110m, with 6 branches
- RC3: average channel, length 210, with 8 branches
- RC4: bad channel, residential space and strong branching

2.3. Bit Error Rate (BER):

When some bits are transmitted from a transmitter, some of these bits are changed in the course of travelling from transmitter to receiver due to the noise present in the channel, hence these bits are received as errored bits eg. 1 is changed to 0. So the BER is defined as the ratio of number of bits in error to the total number of transmitted bits. For eg, if 10000 bits are transmitted and out of which 100 bits are received in error, then we can say the average Bit Error Rate equals the number of bits in error i.e. 100 divided by the total number of bits transmitted i.e. 10000. Then the Bit Error Rate is 0.01 or 1%

$$BER = \frac{\text{Number of Bits in Error}}{\text{Total number of Bits transmitted}} = \frac{100}{10000} = 0.01 \text{ or } 0.01\%$$

2.4. Orthogonal Frequency Division Multiplexing:

OFDM is basically a multi carrier modulated system [4]. Here the bandwidth of the channel is split into N parallel sub-bands, and each of these sub-bands are having different N subcarriers. The frequency of these subcarriers are spaced at the fundamental frequency F_0 i.e. $F_0, 2F_0, 3F_0, \dots, (N-1)F_0$. The high-speed data symbols are spitted into slower data streams, thus increasing the symbol duration and hence reducing the effect of impulsive noise which produces due to various electrical equipments connected in the power line. This also lessens the impact of multipath and Inter Symbol Interference as the symbol duration becomes more than the time delay i.e. Each of these slower data streams are used to modulate the subcarriers. By using cyclic prefix efficiency can be further increased by eliminating Inter Block Interference by converting the frequency selective fading into flat fading channel.. We require multiple oscillators to generate carrier frequencies, and to maintain the orthogonality of the sub-carriers these carrier frequencies must be precisely centered at the fundamental frequency. Now, if we require thousand bits to be transmitted in parallel then we require thousand such oscillators. We can replace the use of these oscillators by performing IFFT/IDFT operation at the transmitter side. At the receiver side we will perform the inverse of IDFT/IFFT i.e. Discrete Fourier Transform (DFT) or Fast Fourier Transform (FFT) to recover back the transmitted symbols without using multiple coherent detectors.

2.5 Overall System Configuration:

To analyze and study the performance of the multipath power line channel model, OFDM modulation scheme used with BPSK and QPSK. The figure illustrate Orthogonal Frequency Division Multiplexing (OFDM). System block diagram is used for this purpose. BPSK and QPSK modulation are used as the modulation scheme.

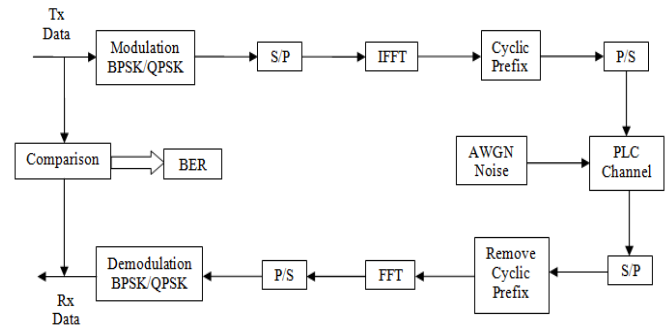

Fig - 6: PLC-OFDM System Architecture

Various steps in PLC-OFDM transmitter are given as follows:

i. Modulation

In initial step serial data is modulate by using any modulation scheme such as Binary Phase Shift Keying (BPSK) or Quadrature Phase Shift Keying (QPSK). In this thesis both schemes are used.

ii. Serial-to-Parallel (S/P) Converter

The modulated data is a serial data which is converted into parallel data by using serial to parallel converter. Because IFFT requires the parallel data streams of data for further processing.

iii. Inverse Fast Fourier Transform (IFFT)

After generation of parallel streams, IFFT block convert frequency domain signal into a time domain signal. The output sequences of the IFFT are orthogonal to each other. With the absence of local oscillators, the OFDM system complexity has been significantly reduced.

iv. Cyclic Prefix Insertion

The Cyclic Prefix is a technique in which last part of OFDM symbol is copied to the beginning of the OFDM symbol. It is used to avoid Inter Block Interference (IBI).

v. Parallel to Serial (P/S) Converter

Again the OFDM signal is converted back to serial data in order to send it through the channel.

vi. PLC Channel and Noise

The channel under consideration is multipath power line channel. The OFDM signal experiences variation in phase and amplitude of subcarriers due to power line channel characteristics and noise which adds up in the channel.

vii. Receiver end

At the receiver end, all the above mentioned steps are performed in exactly reverse manners. And the message signal is recovered back.

viii. BER Calculation:

At the last the received signal is compared with the transmitted signal to calculate the Bit-Error-Rate(BER) for different values of SNR.

3. SIMULATION AND RESULT ANALYSIS

Here we are using MATLAB for simulation, which is a high-performance language for technical computing. Steps used in MATLAB Simulation

1. Save all the target equations.
2. Write a program code in MATLAB to perform the simulation, the code is written for the performance evaluation of the PLC-OFDM.
3. Now in code input the values of Rference Channels parameters.
4. Save & compile the program in MATLAB.
5. Get the final result after simulation done by MATLAB.

3.1. Flowchart For Simulation:

Steps involve for the proposed simulation are as follows:

1. Generation of the Random Binary Sequence
2. QPSK/BPSK modulation
3. Serial to Parallel Conversion
4. Performing Inverse Fast Fourier Transform
5. Cyclic Prefix Addition
6. Parallel to Serial Conversion
7. Convolving this data with the Reference Channel coefficients
8. Adding White Gaussian Noise
9. Serial to Parallel Conversion
10. Cyclic Prefix Removal
11. Performing Fast Fourier Transform
12. Parallel to Serial conversion
13. QPSK/BPSK Demodulation
14. Counting the number of bits in error
15. Repeating for the multiple values of E_b/N_0

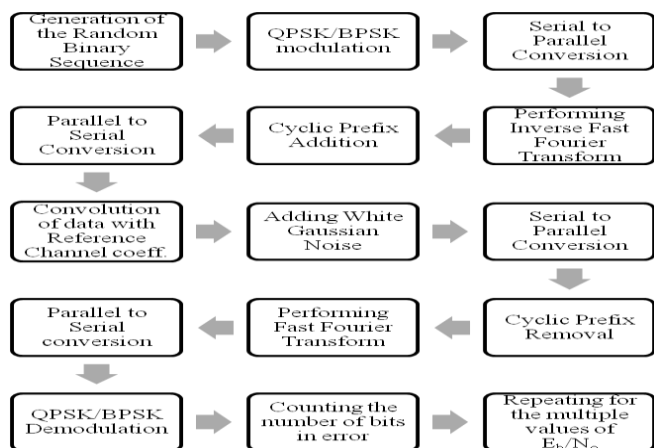

Fig - 7: Flowchart of Simulation

3.2. Reference Channels:

The reference channels are used for the study of physical properties of the channels and overall performance variation. Here two reference channels are used RC1 and RC4. RC1 is an ideal reference channel which is proposed in this thesis, and RC4 is the existing type of reference channel, which is used in the electrical network of residential areas. The parameters of these reference channels are given in the table. We are going to compare the BER of the data transferred from both there Reference Channels and find out which Reference Channel is better and can be used for the transmission of data over Power Line Cables.

3.3. Parameters of Reference Channels:

Table 3: Parameters for Reference Channel 1 and Reference Channel 4

REFERENCE CHANNEL 1			REFERENCE CHANNEL 4		
Attenuation Terms:			Attenuation Terms:		
K=1	$a_0 = 0$	$a_1 = 1.5 \times 10^{-9}$	K=1	$a_0 = 8 \times 10^{-3}$	$a_1 = 3.5 \times 10^{-9}$
Path Parameters:			Path Parameters:		
i	g_i	d_i	i	g_i	d_i
1	+0.60	100	1	+0.26	300
2	-0.08	130	2	+0.05	350
3	+0.08	160	3	-0.30	370
4	-0.08	190	4	+0.25	450
5	+0.15	300	5	-0.35	510

3.4. Result Analysis:

The results obtained from the simulation of the MATLAB program is analyzed [5] in this part. The results are in form of BER v/s SNR curve. In the graphs the comparison between various plots are made for two different modulation techniques i.e. BPSK and QPSK. Additive White Gaussian Noise is used to corrupt the channel. The BER performance is achieved by adding the PLC impulse response into the system, in a realistic PLC environment.

Now power line channel performance is evaluated using a Multipath Channels i.e. RC1 and RC4 across the same signal to noise ratio (SNR) values. The comparison is done between four plots for both the modulations i.e. BPSK and QPSK. Among these four plots, the first plot refers to the BPSK/QPSK-OFDM transmission over the Reference Channel 4 with an AWGN noise, which is our existing reference channel that represents topology of residential area with large branching and channel length of around 500 meters. The second plot refers to the BPSK/QPSK-OFDM transmission over the Reference Channel 1 with an AWGN noise, which is our proposed reference channel, with no

branches and cable length of 100 meters only. Third plot refers to the BPSK/QPSK-OFDM over the ideal channel with AWGN noise only. The fourth plot refers to theoretical BER of BPSK which is given by the formula i.e. it's minimum BER for any type of communication.

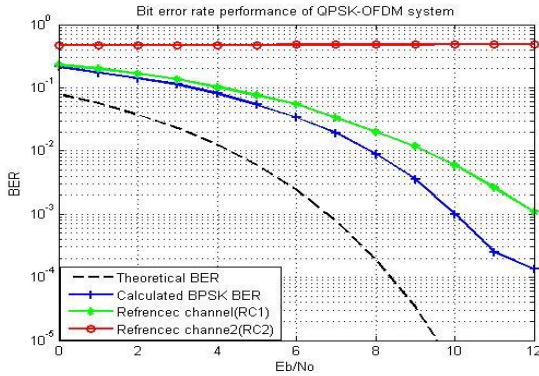

Fig - 8: BER performance of QPSK-OFDM PLC System

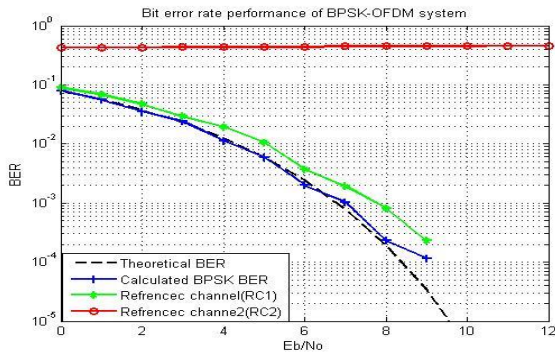

Fig - 9: BER performance of BPSK-OFDM PLC System

The plots shows the BER v/s SNR curve. The lower the plot lower is the BER value and better is the communication. Also with the increasing value of SNR the plot moves down i.e. BER reduces, hence for better BER we need higher SNR.

Now from the graphs is clearly visible that the data which is transmitted through the reference channel 4, which represents an existing residential topology, the BER curve doesn't converge and goes straight i.e. higher BER and hence poor communication channel. Thus certainly this channel cannot be used for the data transfer through it. If done so, out of total transmitted bits large number of bits will be received in error, and definitely cannot be recovered back. But if we look at the curve which represents the BER of the signal transmitted over the reference channel 1, which is our proposed reference channel with no branches and length 100 meters which is smaller than the presently used PLC lengths, we can observe that this curve converges downwards towards the theoretical BER of the BPSK/QPSK modulation. This indicates that BER can be significantly reduced if use this type of channel for communication purpose. Thus we can clearly say, if we do the wiring in our household, whose topology is similar to our proposed Reference Channel 1 i.e. no branches and wire length only

upto 100 meters, we can definitely transmit the data signals over the PLC successfully.

Now if we look at both the graphs we can see that the BER for QPSK-OFDM is higher than BER for BPSK-OFDM, which is true because BER of QPSK lower than that of BPSK, but we have compromise with the bandwidth. The BER of the BPSK is twice that of QPSK but the bandwidth required for BPSK is twice to that of QPSK.

4. Conclusions drawn from Results:

The work presented in this paper mainly requires the channel modeling of a power line communication channel. An accurate channel model is needed for a complete evaluation of any system. From the simulation graphs we can conclude that the Power Line Cables can be efficiently used for the data communication if the length of the wire is kept to be 100 meters and without branching. Also the BPSK-OFDM is better compared to QPSK-OFDM in terms of BER.

REFERENCES

- [1] Patric J. Langfeld, "The Capacity of typical Power Line Channels and Strategies for System Design", in Proc. of 5th Int'l. Symp. Power-Line Commun., Malmö, Sweden, 4.4.-6.4., pp. 271-278, 2001
- [2] Manfred Zimmermann and Klaus Dostert, "A Multipath Model For The Powerline Channel", IEEE Transactions on Communications, vol. 50, no. 4, pp. 553-559, 2002
- [3] Stefano Galli and Thomas C. Banwell, "A Deterministic Frequency-Domain Model for the Indoor Power Line Transfer Function", IEEE Journal on Selected Areas in Communications, vol. 24, no. 7, pp. 1304-1316, 2006
- [4] Amarisa Maneerung, Suvapon Sittichivapak and Komsan Hongesombut, "Application of Power Line Communication with OFDM to Smart Grid System", in Proc. of 8th International Conf. on Fuzzy Systems and Knowledge Discovery (FSKD), pp. 2239-2244, 2011
- [5] Charles U. Ndujiuba, Samuel N. John and Oladimeji Ogunseye, "Improving Data Transmission Efficiency over Power Line Communication(PLC) System Using OFDM", International Journal of Applied Engineering Research, vol. 12, no. 5, pp. 705-710, 2017
- [6] Matthis Gotz, Manuel Rapp and Klaus Dostert, "Power Line Channel Characteristics and their Effect on Communication System Design", IEEE Communication Magazine, vol. 42, no. 4, pp. 78-86, 2004