

Diode Clamped Multilevel Inverter for Induction Motor Drive

Sajal S. Samarth¹, R. A. Keswani²

¹Department of Electrical Engineering, Priyadarshini College of Engineering, Nagpur, Maharashtra, India

² Associate Professor, Department of Electrical Engineering, Priyadarshini College of Engineering, Nagpur, Maharashtra, India

Abstract - Multilevel inverters are very versatile technology and advancement in the field of power electronics. In this paper, five-level diode clamped multilevel inverter fed induction motor drive is explored related to reduction in the harmonic distortion thereby improving motor performance. Induction motor is the mostly used electric drive now a day. Most of the times for efficient control of the motor, inverter drives are used and various sources of electrical energy are employed. Multilevel inverter provides several staircase voltage levels during different phases from the capacitor banks. As the number of voltage levels increases, the output voltage appears to be approximate sinusoidal waveform, which has a reduced harmonic distortion. However, high number of levels increases the control complexity and introduced voltage imbalance. The main objective is to propose a Multilevel Inverter System Drive fed by Solar Energy as renewable source and check the performance of the system.

Key Words: Diode Clamped Multilevel Inverter (DCMLI), Total Harmonic Distortion (THD), Voltage Source Converter (VSC), unbalance DC link voltage, high efficiency, Multilevel Boost Converter (MBC)

1. INTRODUCTION

Nowadays the Multilevel Inverters (MLI) are found in various applications for medium voltage and high power system. Many MLI converter topologies have been developed so far. However, the elementary concept of a MLI to achieve high power is to use series of power semiconductor switches with several lower voltage DC sources to perform the power conversion by synthesizing a staircase voltage waveform. MLI topologies have attracted a lot of attentions of energy control in the field for high power and medium voltage applications.

Compared to traditional two-level VSCs, multilevel VSCs present several advantages such as, higher AC voltage levels, reduced harmonic distortion, relatively lower voltage stress on semiconductor switches, operation at reduced switching frequency, reduced voltage slew-rates and lower electromagnetic interference [1,2]. Despite of all these advantages, there is one major drawback of DCMLI i.e. fluctuation of the DC bus voltages. The number of level increases in multilevel inverter the control method gets complexity, so unbalance problems are occurred in DC bus voltages of diode clamped multilevel inverter [4-6]. The voltage unbalance problem reduces the efficiency of output voltage in diode clamped multilevel inverter. Multilevel

boost converter can be used to balance the DC bus voltages.

This paper proposes a multilevel boost converter integrated with renewable source to balance the dc link voltage of the five level diode clamped multilevel inverter. Therefore, in this case voltage unbalance problems are determined and the efficiency of the motor can be improved.

2. PROPOSED MODEL

Solar panel absorbs the maximum solar radiation at constant temperature thereby giving its voltage and current. The solar panel voltage is given to the multilevel boost converter. The multilevel boost converter is to boost the dc voltage from the solar panel and then the boosted dc voltage is given to the 3phase five level diode clamped multilevel inverter. The SPWM method is used to trigger the switch of DCMLI. The PWM is used to control the switch of both MBC and DCMLI and then the inverter feeds the AC load. The basic block diagram of the proposed model is shown in Figure 1.

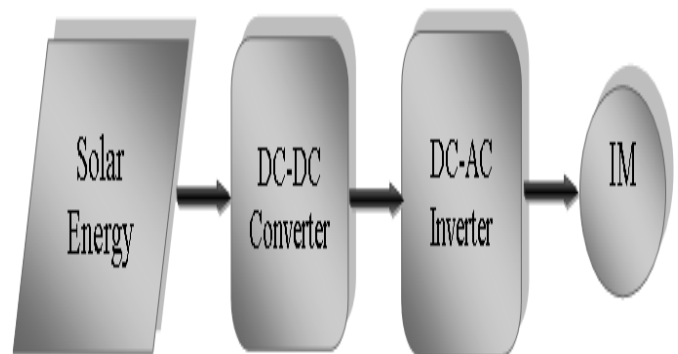

Fig -1: Block Diagram of the Proposed Model

2.1 Solar Panel Equivalent Module

For implementing the proposed scheme, Solar energy as a renewable energy source is used. Solar Power PV module using MATLAB/ Simulink is designed. The equivalent PV module is developed in MATLAB with look up table and controlled voltage source blocks. The design of this equivalent PV module is based on the reference taken from the characteristics of the WS-240 PV Module. Typical Electrical parameters of this module are given in table 1.

Table -1: Electrical Parameters of PV Module

PARAMETER	VARIABLE	VALUE
Maximum Power	P_m	240W
Open Circuit Voltage	V_{oc}	37V
Short circuit current	I_{sc}	8.65A
Voltage at P_m	V_m	30.60V
Current at P_m	I_m	7.85A
Module Efficiency	$\% \eta$	14.78%
Maximum system voltage	V	1000V

From the I-V characteristics at 25°C, the V and I parameters are taken which serves as the reference module. Equivalent module is developed in MATLAB using look up table technique and this module is developed in multiple module arrays wired in series/ parallel combination as required to meet voltage and current requirements.

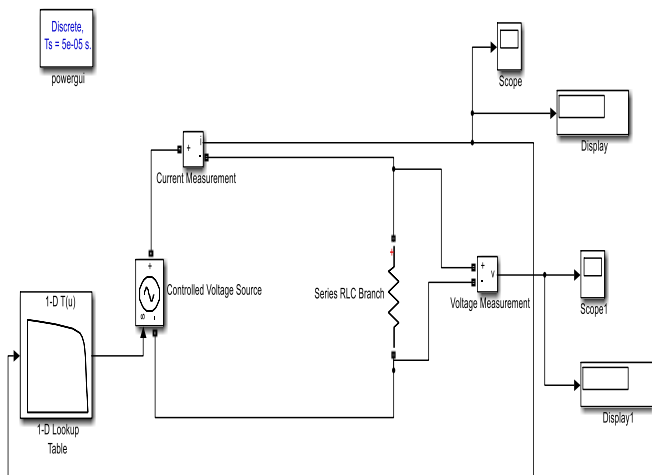

Fig -2: PV Module Simulation in MATLAB

2.2 Multilevel Boost Converter

The multilevel boost converter consists of one inductor, one switch, 2N-1 diodes and 2N-1 capacitors for an N_x converter. The schematic diagram of Multilevel Boost Converter is shown in Figure 3

The operation of MBC depends upon the gate pulse given to the switch for triggering. The multilevel boost converter is to boost the input voltage from the solar panel. But the solar panel generated voltage cannot remain constant throughout. Hence, the output of MBC also fluctuates. In order to maintain constant output voltage of converter, a voltage feedback controller is employed which controls the duty cycle. The multilevel boost converter is designed in MATLAB/ Simulink.

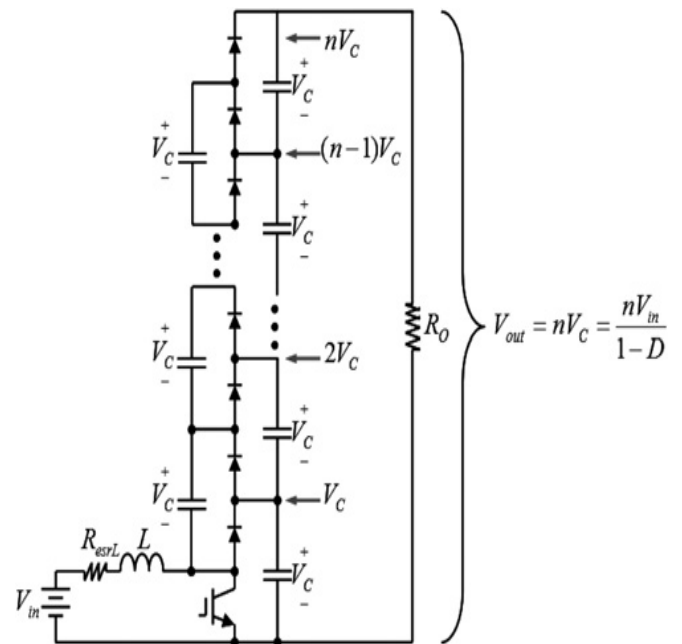

Fig -3: Schematic diagram of Multilevel Boost Converter

3.2 Diode Clamped Multilevel Inverter

A diode clamped five level converter dc link is made of four capacitors and the capacitors are connected in series. The dc link capacitors consist of $C_1, C_2, C_3,$ and C_4 . The DC bus voltage across each capacitor is $V_{dc}/4$. The circuit diagram of Diode clamped five level converters is shown in Figure 4.

The principle of operation of DCMLI is

- For output voltage $V_{ac} = V_{dc}/2$, turn on all upper switches S_1 through S_4 .
- For output voltage $V_{ac} = V_{dc}/4$, turn on three upper switches S_2 through S_4 and one lower switch S_5 .
- For output voltage $V_{ac} = 0$, turn on two upper switches S_3 through S_4 and two lower switches S_5 and S_6 .
- For output voltage $V_{ac} = -V_{dc}/4$, turn on one upper switch S_4 and three lower switches S_5 through S_7 .
- For output voltage $V_{ac} = -V_{dc}/2$, turn on all lower switches S_5 through S_8 .

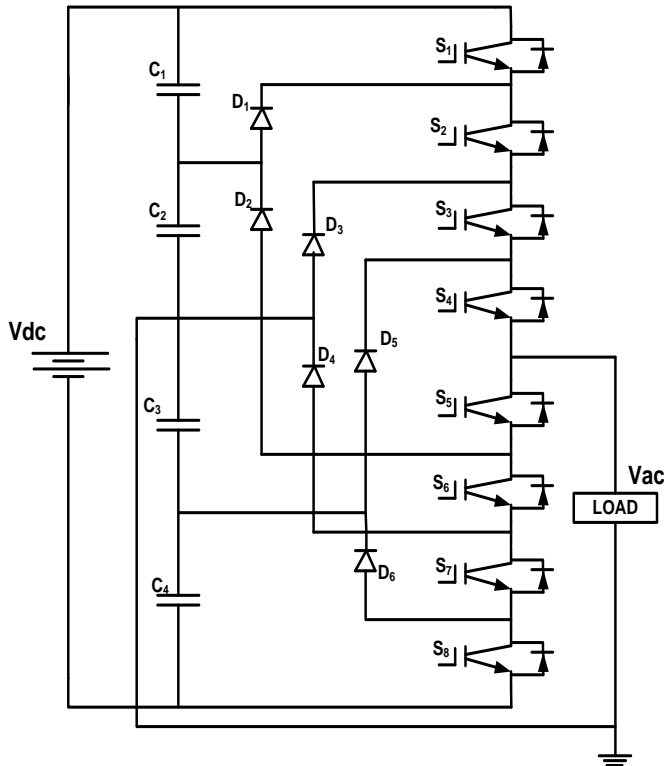

Fig -4: Diode Clamped Five Level Inverter

inverter is also performed and is shown in figure 8. In this case, THD percentage is found out to be 33.59%.

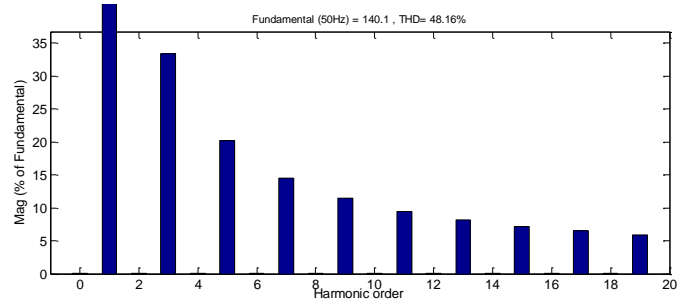

Fig -7: FFT Analysis of Output Voltage of Two Level Inverter

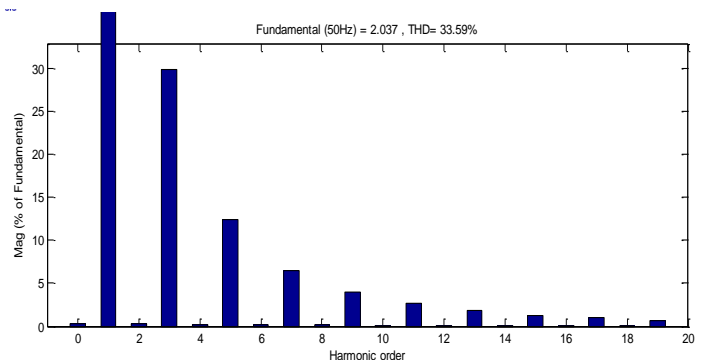

Fig -8: FFT Analysis of Output Voltage of Two Level Inverter

3. SIMULATION & RESULTS

Waveform of the two level output voltage and current of the inverter which is given to the motor is shown in figure 5 and 6 respectively.

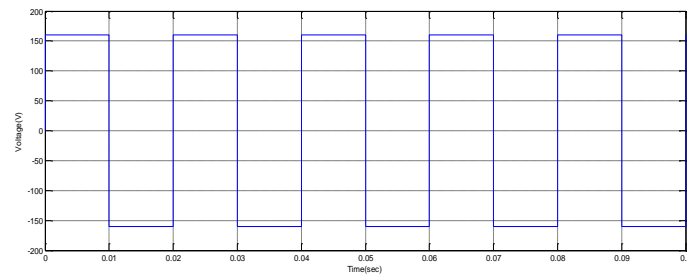

Fig -5: Output Voltage of Two Level Inverter

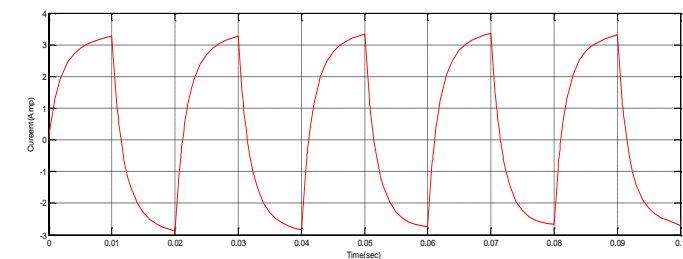

Fig -6: Output Current of Two Level Inverter

By using the Fast Fourier Transform Analysis of the two level inverter output voltage, Total Harmonic Distortion is calculated. The results of the FFT analysis in MATLAB are shown in figure 7 and THD is found out to be 48.16%. Similarly, FFT analysis of output current of the

Figure 9 shows the output voltage of a five level inverter varying from 160V to -160V on y axis against the time in seconds on x axis. Figure 10 shows the output current of Diode Clamped Inverter.

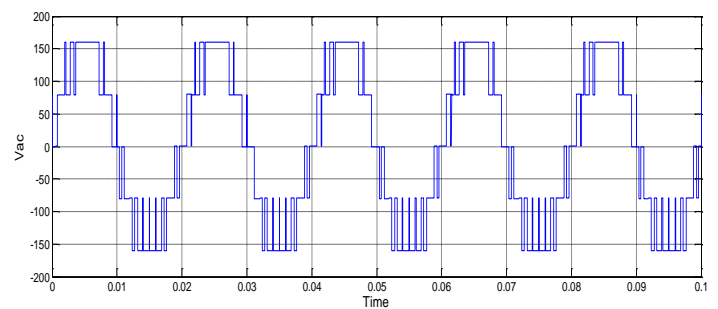

Fig -9: Output Voltage of Diode Clamped Five Level Inverter

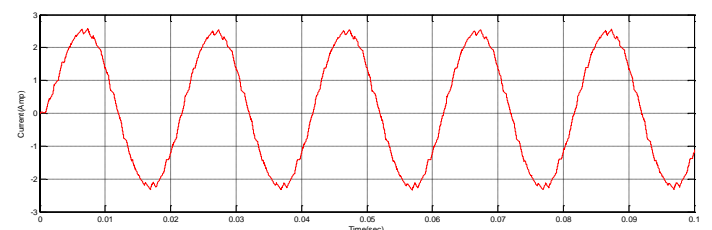

Fig -10: Output Current of Diode Clamped Five Level Inverter

The result of the FFT analysis in MATLAB is shown in figure 11 and THD is found out to be 48.16%. Similarly, FFT analysis of output current of the inverter is also done and is shown in figure 12. In this case, THD percentage is found out to be 4.10%.

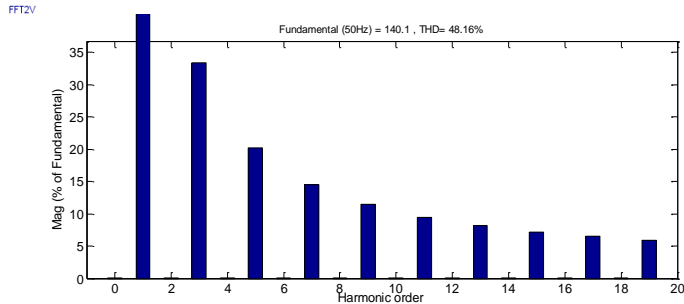

Fig -11: FFT Analysis of Five level Diode Clamped Inverter Output Voltage

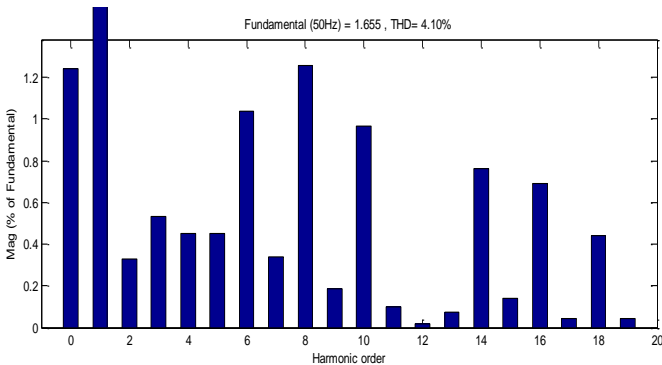

Fig -12: FFT Analysis of Five level Diode Clamped Inverter Output Current

The simulation model of the proposed system is shown in figure 13. The output voltage of the PV Cell is shown in figure 14.

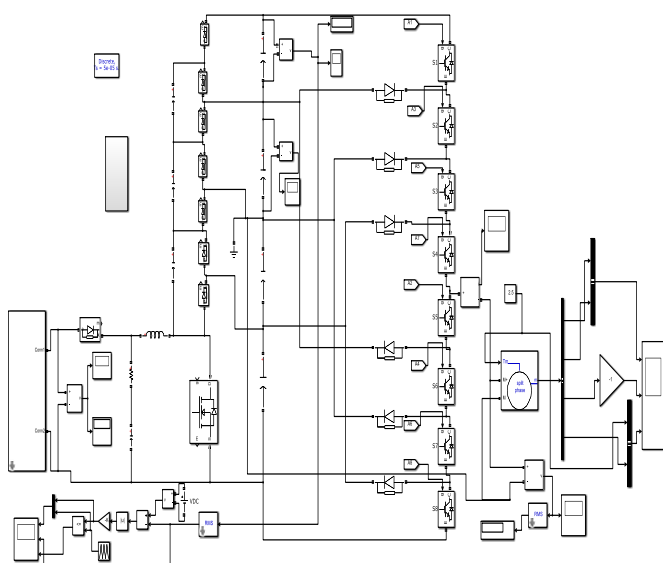

Fig -13: Simulation of the Proposed System in MATLAB

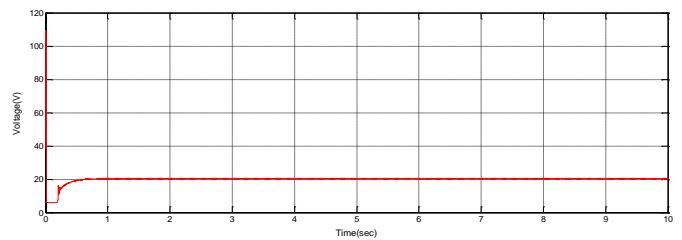

Fig -14: Output Voltage of PV Module

Figure 15 shows the voltage across a capacitor at the output of Multilevel Boost Converter.

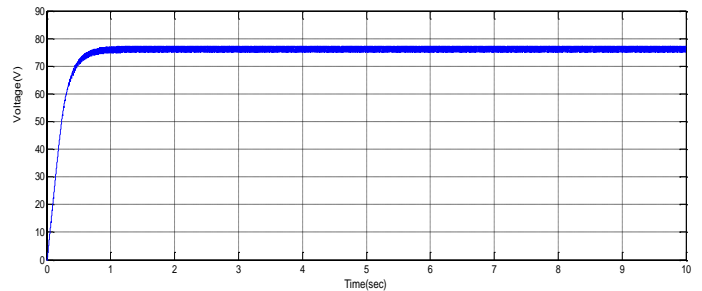

Fig -15: Voltage across a capacitor at the output of Multilevel Boost Converter

Figure 16 shows the waveform of output voltage of diode clamped multilevel inverter.

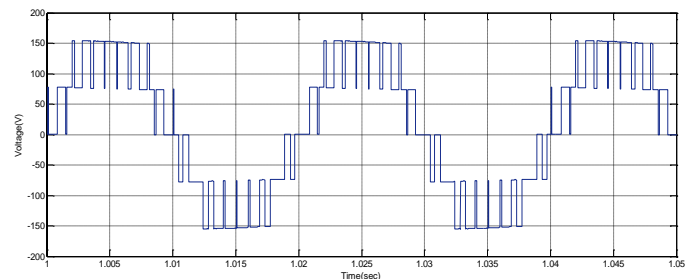

Fig -16: Output Voltage of Inverter

Figure 17 shows the output parameters of single phase induction motor. It consists of auxiliary and main winding current in amperes, speed in radian/second, and torque in N-m.

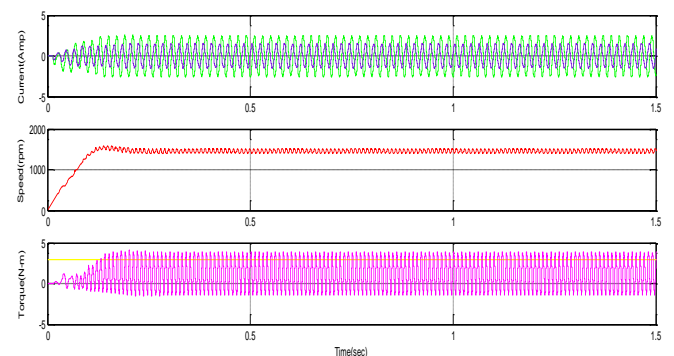

Fig -17: Induction Motor Output Parameters

3. CONCLUSIONS

A comparative analysis of the two level inverters with the multilevel (5-level) diode clamped inverter indicates that the harmonic contents in the output current of two level are more. With the use of the "Five Level Diode Clamped Inverter" the harmonic contents in the output current is reduced. Hence the efficiency of the inverter and system is increased. The solar fed inverter drive system is proposed in the paper. The output of the solar panel is not always constant and varies with the solar irradiations. Hence the output of the multilevel boost converter is also not constant. It means that the dc link voltage of the multilevel diode clamped inverter is not constant. The balance between the voltages of dc link capacitor in diode clamped multilevel inverter is achieved using multilevel boost converter with a feedback path where the inverter output voltage is compared with the set desired voltage. Thus, the unbalance in the voltages of DC link is determined and eliminated thereby efficiency of the motor can be improved. By implementing this technique, high conversion efficiency is obtained. The simulation results for obtaining the balance dc link voltage and hence input the motor is obtained.

REFERENCES

- [1] Mohammadreza Derakhshanfar, "Analysis of different topologies of multilevel inverters", Master of Science Thesis, Department of Energy and Environment, Division of Electric Power Engineering, Chalmers university of technology Göteborg, Sweden, 2010
- [2] Xiaoming Yuan, and Ivo Barbi, "Fundamentals of a New Diode Clamping Multilevel Inverter", IEEE Transactions On Power Electronics, Vol. 15, No. 4, July 2000
- [3] Praveen Bansal, "Matlab /Simulink based Analysis of Photovoltaic Array Fed Multilevel Boost Converter", National Conference on Emerging Trends in Electrical Engineering, Vol 4, No 7, 2013
- [4] M. Ranjitha, N. Mohananthini, M. Swathisriranjani "Voltage Balancing In Diode Clamped Multilevel Inverter Using Multilevel Boost Converter" , International Journal of Advanced Research in Electrical, Electronics and Instrumentation Engineering, Vol. 6, Issue 1, January 2017
- [5] Avanish Tripathi, and G. Narayanan "Evaluation and Minimization of Low-Order Harmonic Torque in Low-Switching-Frequency Inverter-Fed Induction Motor Drives" IEEE Transactions On Industry Applications, Vol. 52, No. 2, March/April 2016
- [6] Grain P. Adam, Stephen J. Finney, Ahmed M. Massoud, and Barry W. Williams "Capacitor Balance Issues of the Diode-Clamped Multilevel Inverter Operated in a Quasi Two-State Mode" IEEE Transactions On Industrial Electronics, Vol. 55, No. 8, August 2008
- [7] Hongliang Wang, Lei Kou, Yan-Fei Liu and Paresh C. Sen, "A New Six-Switch Five-Level Active Neutral Point Clamped Inverter for PV Applications" IEEE Transactions On Power Electronics, Vol. 32, No. 9, September 2017
- [8] B. S. Umesh and K. Sivakumar, "Multilevel Inverter Scheme for Performance Improvement of Pole-Phase Modulated Multiphase Induction Motor Drive" IEEE Transactions On Industrial Electronics, Vol. 63, No. 4, April 2016
- [9] R.Nagarajan, R.Yuvaraj, V.Hemalatha , S.Logapriya , A.Mekala , S.Priyanga, " Implementation of PV - Based Boost Converter Using PI Controller with PSO Algorithm" International Journal Of Engineering And Computer Science ISSN:2319-7242 Volume 6 Issue 3 March 2017, Page No. 20479-20484
- [10] Hongliang Wang, Lei Kou, Yan-Fei Liu, and Paresh C. Sen, "A Seven-Switch Five-Level Active-Neutral-Point-Clamped Converter and Its Optimal Modulation Strategy" IEEE Transactions On Power Electronics, Vol. 32, No. 7, July 2017
- [11] Manish V Kurwale, Er.N.C.Amzare, Palak G. Sharma, "Analysis of Five Level Diode Clamped Multilevel Inverter Using Discontinuous TPWM Technique" International Journal of Advanced Research in Electrical, Electronics and Instrumentation Engineering, Vol. 4, Issue 5, May 2015