

Power management system for electric vehicle charging stations using fuzzy logic controller

M Sruthi¹, N.PrakashReddy²

¹P.G. Student, Department of Electrical and Electronics Engineering, SPMVV, Tirupati, India

²Assistant professor, department of Electrical and Electronics Engineering, SPMVV, Tirupati, India

ABSTRACT:- By the end of this decennium electric vehicles are growing risk that, the rapid augmentation in number of PHEVs will demand during rush hours due to extreme surges while charging. To reduce these surges, a special charging station structure is introduced for charging of the PHEVs to maintain rate of charging, so that the high load period of charging is not burden on grid. For charging of PHEVs the required power is comes from utility or photovoltaic generator connected with grid or both. The model is the three ways interaction between the PV, PHEVs and the grid to usage of power availability charging time stability. The design criteria of PV cell, DC/DC converter and grid connected DC/AC bi-directional inverter which belong to the photovoltaic system are determined and Simulink models are established in this study. The control of DC/AC Bi-directional converter is ensured by using fuzzy logic and PI control. The results of fuzzy logic and PI control were compared. It was seen in the result of simulation that fuzzy logic control is more efficient than PI control, by using fuzzy controllers we can reduce the harmonics.

Index Terms: Hybrid electric vehicle, photovoltaic, DC/DC boost converter, DC/AC bi-directional converter, PI controller, fuzzy logic controller

I. INTRODUCTION:

Urbanization has caused many affects on public life. Presently, the daily activities are mainly dependent on vehicles. So the density of vehicles in city areas is increasing day by day. Mainly, many of these vehicles are all dependent on non-renewable energy resources like petrol and diesel. These resources are extinguishing day by day and may not last long. People are also taking war in certain countries because of oil crisis with political instability. With all these factors, it's seen that the prices of oil going high day by day making the common man's life unbearable.

The growing global awareness for a pollution free environment, will lead to an increase in the number of PHEVs in the near future. This triggers the need for charging stations that can satisfy the requirements for a significant amount of power needed to charge the PHEVs. The proliferation of these PHEVs will add stress to the already overloaded U.S grid creating new challenges for the distribution network. Though it is always advantageous to charge the EV's during night time there

will be considerable PHEV load during the day and even during the hours of peak demand. Transmission and distribution systems can be upgraded to meet the peak demand but this may result in capacity surplus during normal operating conditions. There is also a potential risk of night-charging challenge as the TOU (time-of-use) pricing is designed to discourage charging during the daytime. This would overload the distribution transformers which are otherwise designed to cool overnight. Though installing transformers with higher power rating would solve the problem, it is a rather expensive option. Hence, it's time to develop charging station infrastructure coupled with smart charging strategies which can reduce the stress imposed on the grid. One way is to use renewable energy resources to charge the PHEVs. Photovoltaic systems would be the best choice among the available options as they can be made dispatch able by employing external storage units.

The creation of battery charging station structures is critical to lessen the power request of the framework. Subsequently, sustainable powers sources emerge with develop innovation furthermore, focused on cost. The work did it in was investigated the conceivable effect of electric vehicles would causes the power network at top position.

The creator plans an arrangement of clever control utilizing of photovoltaic framework.

It is important to distinguish the potential issues which are caused by the expansion of clients with module hybrid electric vehicle (PHEVs) sooner rather than later. As per, in the coming years, it won't be conceivable, with the present framework, to take care of the power demand for PHEVs. There are contemplates which talked about the improvement of smart systems to diminish the overhead electrical system and additionally it is assessed the effect caused by the incorporation of individual electric vehicles (PEVs) and PHEV in the electric system with respect to it is proposed programs for the advancement of the vitality.

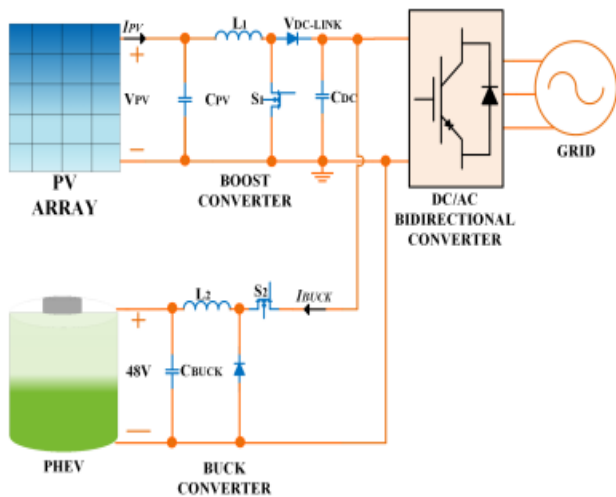

Fig. 1. Schematic of the proposed system.

Also, in was talked about the economy that is accomplished by building up a charging station for electric vehicles.

A correlation between the achievability of building up a stopping in light of PV plates or the proprietor introduce in their own parking space, including the establishment cost and support costs, yet pointing the benefit inside the lifetime of the sun oriented boards . As indicated by the National Family unit Travel Survey, 60 % of the vehicles spend more than 5 hours in the parking places, and in this parking time, they can be energized. The introducing sun oriented gatherers in parking’s parts barn payback time.. **There are three levels of characterization:** Level 1 AC, Level 2 AC and Level 3 DC. For changing the electrochemical batteries through the mains level 1 and level 2 static converters are used. Both are contrast in a pinnacle current, at level 1 current is most of 16A and no level is 80A. To build in general productivity in photovoltaic stations Levels 3 static DC-DC converters are utilized.

In Figure 1, shows the schematic framework for reviving electrochemical batteries of electric vehicles is described. It comprises of a sun based PV generator coupled to a lift converter that offers the DC link connect with an AC-DC converter associated with the network and a DC-DC buck converter which conveys the bank of electrochemical batteries of the EV.

II. DESCRIPTION OF THE SYSTEM:

A. Maximum Power Point Tracking MPPT:

The immediate association of the sun powered board to a gear it shows a low efficiency and does not present voltage direction. The Maximum Power Point (MPP) of the sun based board ceaselessly changes non-direct varieties with the accessible temperature and irradiance. Besides, computational devices are utilized to enhance the

functionality of the board at the purpose of grasping power exchange. There are a few techniques in the writing for the extraction of greatest power, for example, consistent voltage, Open-Circuit Voltage, Short-Current Pulse Circuit, Perturb and Observe, Incremental Conductance, among others. Perturb and Observe (P&O) and Incremental Conductance are the most variable techniques.

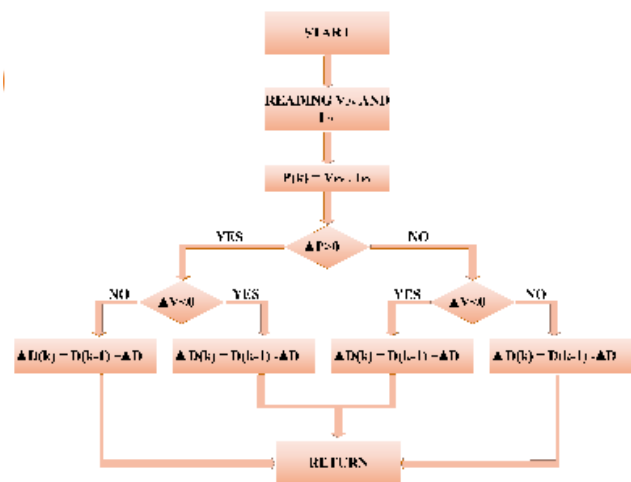

Fig. 2. Schematic of MPPT used.

The calculation actualized in this task was the incremental conductance, in which the sun oriented board voltage (V_{PV}) and the current (I_{PV}). With these the figuring of the power variety of the framework power (ΔP) and the voltage (ΔV) is performed. At the point when the time subordinate of intensity equivalents to zero it will be the MPP of the framework, as shown in Figure 2.

B. Static Converters:

The application attributes must be watched to discover the topologies of the static converters.. It is vital to investigate the working of voltage and energy how much will be produced by the sun powered boards under perfect states of sun based radiation and temperature, voltage is wanted in the DC interface and the ostensible voltage of the battery to discover the topologies of the static converter in MPP.

1) DC/DC Boost Converter:

As before explained, for which the board will work in MPP, it ought to be forced a working voltage board. A static power converter and boar are interconnected with the DC interface so it is conceivable to work the board in the MPP and increasing the voltage. For this examination, it was reenacted the BP Solar boards. In the Figure 3, the MPP simulated from the model reenacted, display in perfect states of temperature and light, 25°C what's more, 1000 W/m². The yield voltage of the board plan exhibit achieves roughly 160 V. the lift converter developed with 0.5duty

cycle and current ripple 2% are shown in figure 4. The lift converter acts as an open mesh, and the MPPT of input board arrangement and duty cycle is varying.

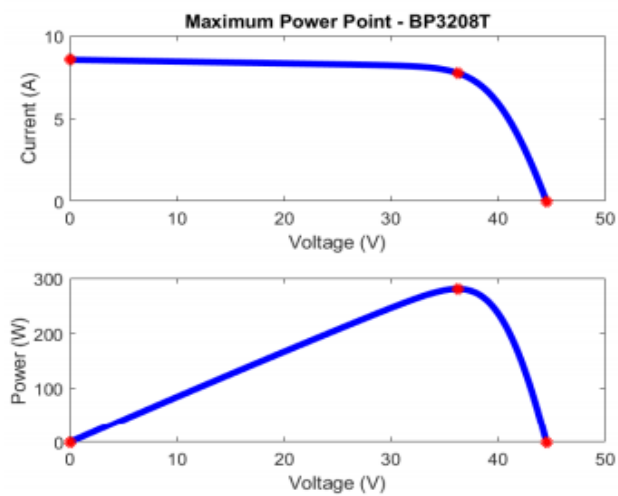

Fig. 3. Solar Panel MPP Curve



Fig. 4. Boost Converter Control.

2) DC/AC Inverter:

To interface with the mains connector and the DC transport, it was utilized a converter Voltage Source Converter (VSC) with dual levels and six switches. Depending on the stumbling of the switches, the inverter operates bidirectional and can infuse or devour control from the circulation network.

In this study, the VSC is performed through the arrangement of synchronized directions or dq in the control system. In the framework, the present pivot in conjunction iq is specifically identified with the stream of receptive power and current direct pivot id with the stream of dynamic power, which is associated with the DC transport. The control system utilized as a part of the VSC is performed through the arrangement of synchronized directions or id.

In the framework, the quadrature pivot current iq is straightforwardly identified with the responsive power transition and the immediate pivot current id dynamic power transition is associated with the DC transport voltage. Furthermore, the quadrature pivot current control is done by a twofold control circle, in which the outside circle controls the transport voltage and through a PI controller reference is inward current circle id, shown in Figure 5.

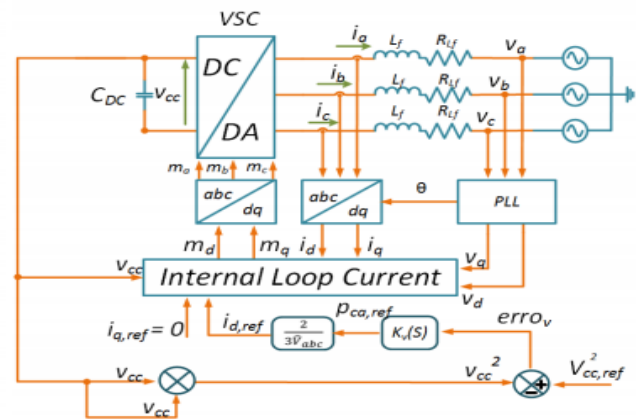

Fig. 5. Schematic of the control used for the VSC

The control was actualized with a vector investigation; voltages are utilized as the reason for the usage of vector control d-q, causing the dynamic and receptive forces are controlled in one circuit. Along these lines, control turns out to be speedier and compelling is more than a scalar control. The Stop Transform plays out the (abc) change of voltages or currents into a symmetrical vector framework that is synchronized with the recurrence of the AC grid.

Keeping in mind the end goal to the VSC framework be synchronized with the mains, a recurrence and stage location framework is utilized at the basic point of common coupling. For this, the estimation of system parameter is the Phase Locked Loop (PLL), in which is generally send out from frameworks of broadcast communications and power electronic being utilized like gadget trackers and removes the recurrence parts.

3) DC/DC Buck Converter:

The methodology used in buck converter is shown Figure 6 which GI (s) speaks to the controller utilized and H(s) the converter model is controlled. For the converter control improvement, it was utilized the technique factor k: a numerical strategy which characterizes the qualities of the recurrence reaction of the converter controller. Despite the converter controller to be utilized, the factor k is one of the approach to get pick up lessening at low frequencies and increment the pick up at high frequencies, by designating the posts what's more, zeros of the venture, in connection to the cut-off recurrence it was utilized the Proportional Integral (PI) controller.



Fig. 6. Control of Buck Converter.

C. Battery Design:

1) Recharge Methods:

It is crucial to think about a few vital elements, for example, stack time accessible and the wage which it is pursuit so as to amplify. These variables are connected so as to acquire a stacking time quicker is required to acquire higher current esteem, subsequently bringing about a lower. Subsequently, it is watched the restricting variables of a charging procedure are temperature and terminal. For battery reviving, there are a few strategies introduced in the writing: present and consistent voltage, steady power, beat current and the blended strategies, which convey the heap exchanging between the strategies specified above.

In this investigation, it was utilized the consistent current stacking technique. Be that as it may, the voltage must be observed all through the charging procedure to keep away from the high voltages in battery.

2) State of charge (SOC):

In frameworks where the battery charge control is performed, it is important to screen its state of charge (SOC). This parameter is basic to stay away from over-burdening or profound release of the battery. The SOC of a corrosive lead battery can be resolved through open circuit voltage or by estimating the causticity of the electrolyte. This last test, nonetheless, isn't achievable, since the batteries are by and large fixed and the electrolyte isn't open.

The connection amongst the open circuit voltage and SOC can be near to a straight conduct. The assurance of the proportion can be performed through testing on drums and some of the time educated by the producer. Be that as it may, the strategy for open circuit voltage isn't appropriate in frameworks where the battery is in control and release process. The technique utilized as a part of this investigation, it is based on the records of the current taken from the battery.

$$SOC(t) = \frac{Q(t_0) + \int_{t_0}^t i_{buck} dt}{Q_{Rated}} * 100 \quad (1)$$

in $Q(t_0)$ is the nominal charge of the input current(A) battery (Ah) $i(t)$. The initial charge of the battery the open circuit voltage and initial load is determined and their nonlinearities, and then its recalculated after some time.

CONTROLLER USING FUZY CONTROLLER:

Fuzzy logic is a form of many truths or false logic values in between 0 and 1.it is in different from Boolean logic, the truth values of variables only be 0 or 1.bur in case of Fuzzy logic it has many ranges in between 0 and 1 they are completely true completely false, partially true, partially false. these are managed by specific functions.

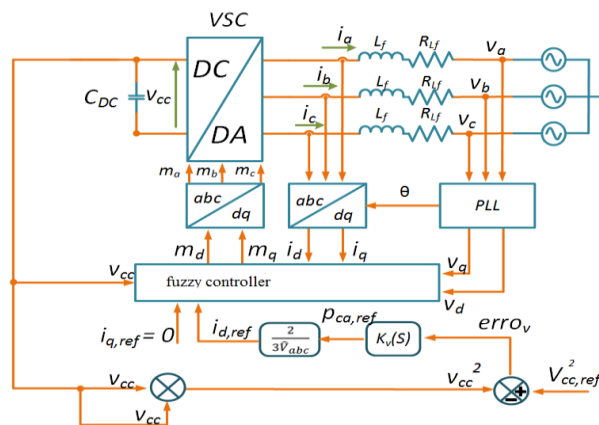
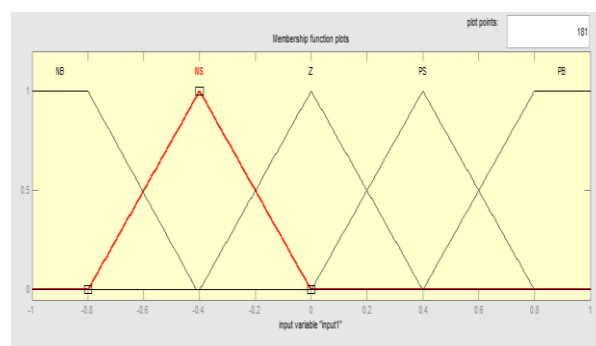
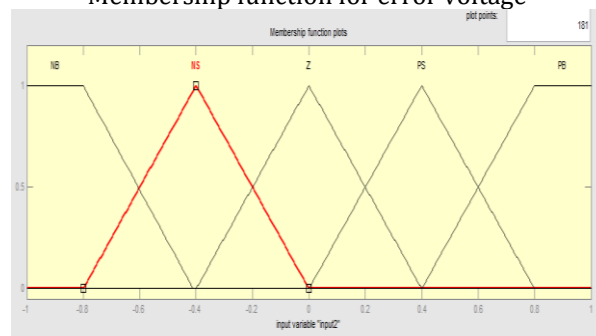

Fig7. Controller block diagram using fuzzy controller



Membership function for error voltage



Membership function for change in error for voltage

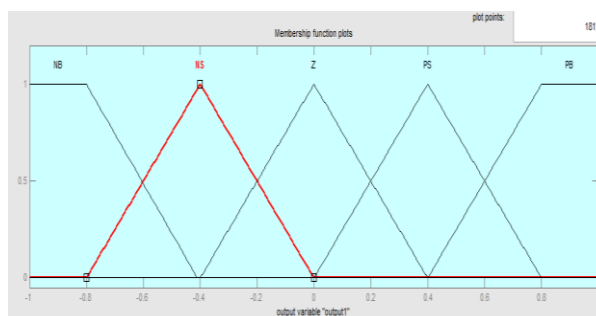

Membership function for current

Fig8: membership functions

The main fuzzy logic controls variables are three. They are the error, range in error and output. Each has five triangle

membership functions. These are shown in fig 8.the fuzzy variables are expressed by linguistic variable from positive big(PB),positive small(PS),zero(Z).

And from negative side negative big(NB), negative small(NS) and zero.(Z) the above rules are sets based on the working of the system.

According to the inputs the rules of the fuzzy logic controller PWM duty cycle is adjusted. We can set the desired number of rules for the five membership functions the numbers of rules are 25 errors and the change in error (inputs of the FLC).

Table 1: Rule base of FLC

e	NB	NS	Z	PS	PB
Δe					
NB	Z	Z	NB	NB	NB
NS	Z	Z	NS	NS	NS
Z	NS	Z	Z	Z	PS
PS	PS	PS	PS	Z	Z
PB	PB	PB	PB	Z	Z

SIMULATION RESULTS:

Simulation results by using PI Control method:

The temperature and radiation of the solar energy throughout the day is shown in graphs. The temperature and radiations were changed in 24seconds due to simulation of static converter dynamic control. And it has switching frequency of 20 khz .

In short intervals there is no sudden changes in temperature and radiation. In this case, there is a more restrictive operating situation compared practice. From the graph noted that the time taken to perform system is 12.27 seconds and state of charge is 0.03%.

The Proportional Integral (PI) controller, which is widely, used thanks to its versatility, discharges benefits and facility of implementation.

A very common method to determine the constants of this controller and Fuzzy logic is very good for nonlinear systems and with very wide ranges of operation with the Fuzzy logic.

The modes of operation sing PI controller and fuzzy logic controller is shown in Fig 9.

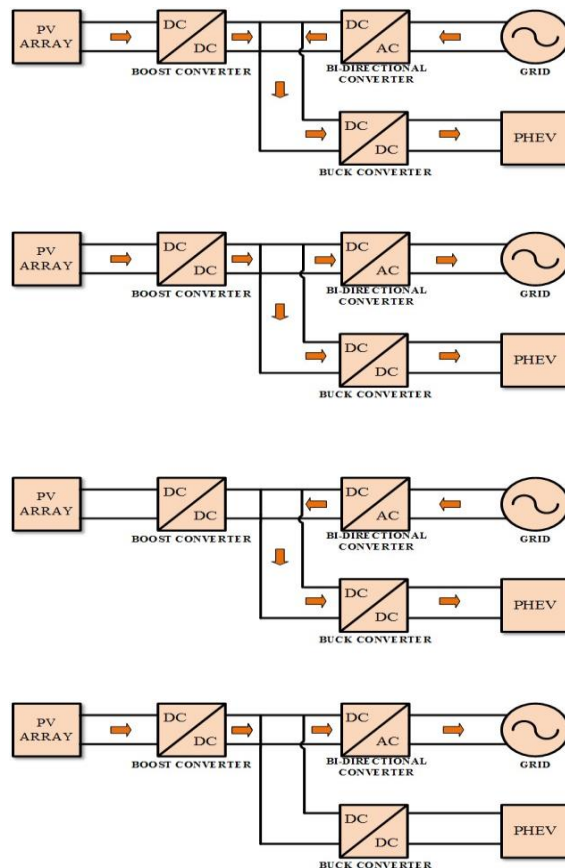

Fig 9: Modes of operation Mode 1: PV charging and Grid connected rectification, Mode 2: Grid connected inversion and PV charging, Mode 3: Grid connected rectification, Mode 4: Grid connected inversion

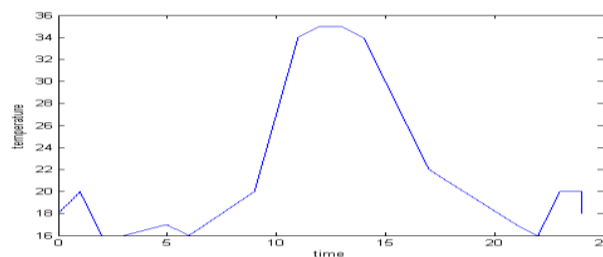

Fig 10. Temperature during one day graph.

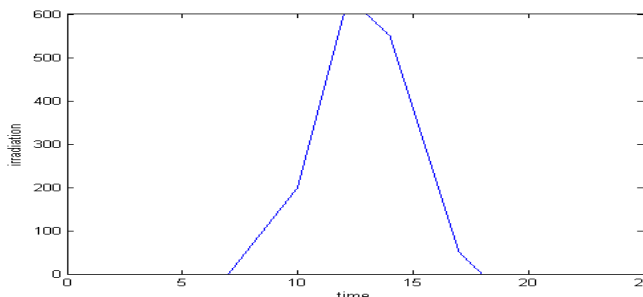

Fig. 11 Irradiation of one day

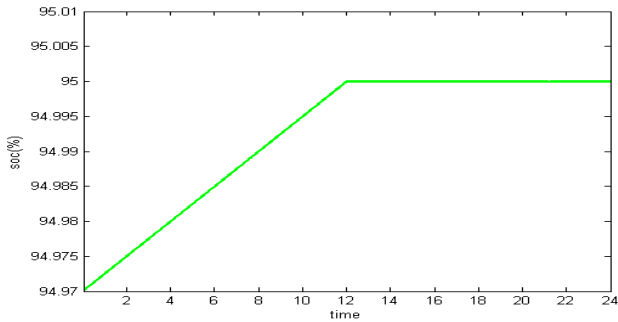

Fig.12 Battery recharge process

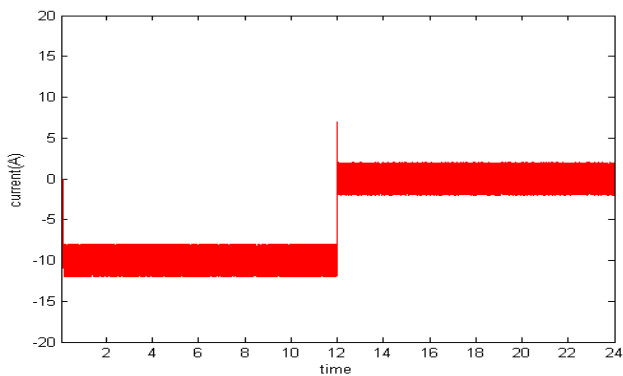

Fig. 13 Control system for battery recharging

it is possible to observe that the recharge the EV is required to control the charge of constant power of the EV up to state of charge reaches 95%. So the vehicle recharge from power grid (MODE 3) and maintains as long as solar radiation is low, when the solar radiation increase the power required from the power grid becomes reduces (MODE1). Then the solar generation is more the power required to charge EV starts receiving from solar and grid power (MODE2). when the solar radiation is decreases the power generated from the solar board is also reduces, then the charging starts repeat MODE1 and MODE3.

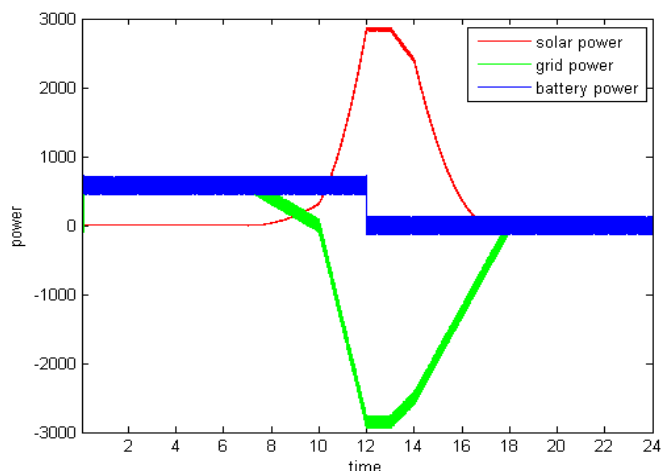

Fig. 14 Power Transfer in the system

Simulation Results by using fuzzy control:

The temperature and radiation of the solar energy throughout the day is shown in graphs. The temperature and radiations were changed in 24seconds due to simulation of static converter dynamic control. And it has switching frequency of 20 khz .In short intervals there is no sudden changes in temperature and radiation. In this case, there is a more restrictive operating situation compared practice. By using fuzzy logic controller we can reduce the harmonics.

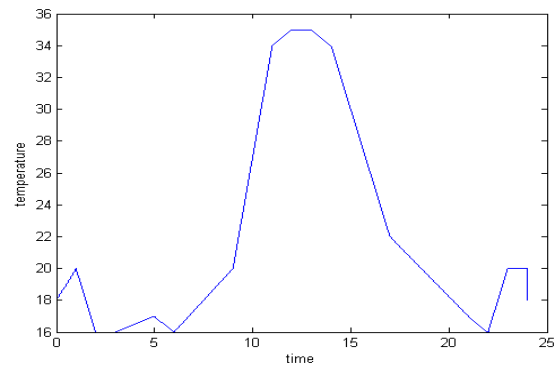

Fig. 15 Temperature during one day graph.

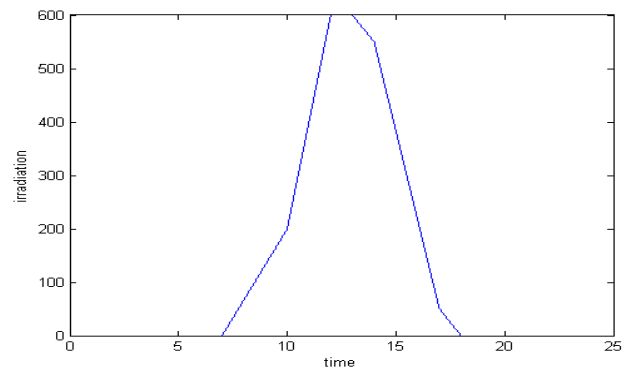

Fig.16 Irradiation of one day

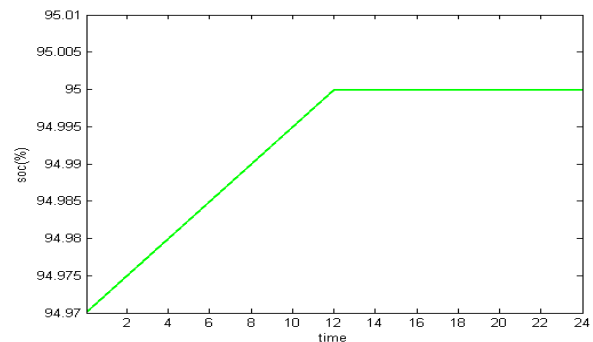

Fig. 17 Battery recharges process

Table 2. FFT analysis

Parameter	PI controller	Fuzzy controller
V _g (THD)	0.54%	0.17%
I _g (THD)	0.54%	0.17%

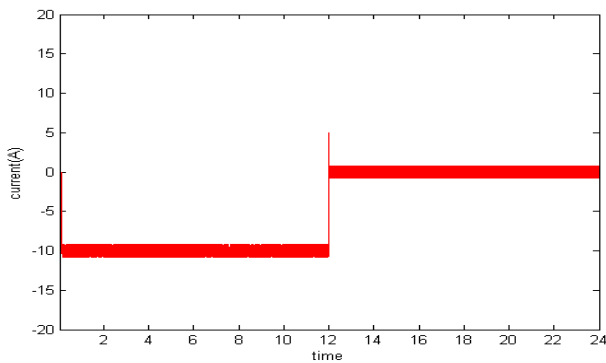

Fig. 18 Control system for battery recharging

It is noted that the system takes approximately 12.27 seconds to perform the 0.03% load of the SOC. By using fuzzy controllers we can reduce harmonics

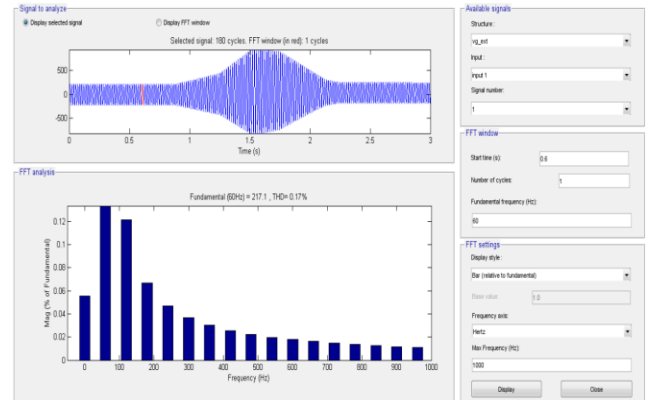

Fig.21 Vg FFT analysis using fuzzy

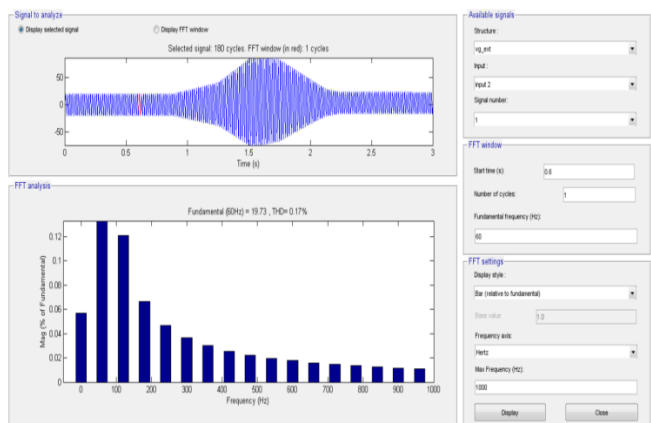

Fig. 22 Ig FFT analysis using fuzzy

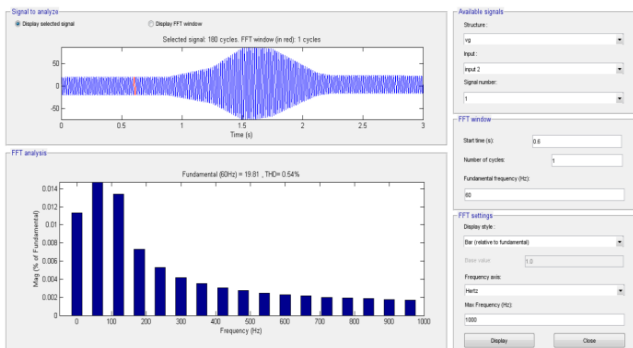

Fig.19 Vg FFT analysis using PI

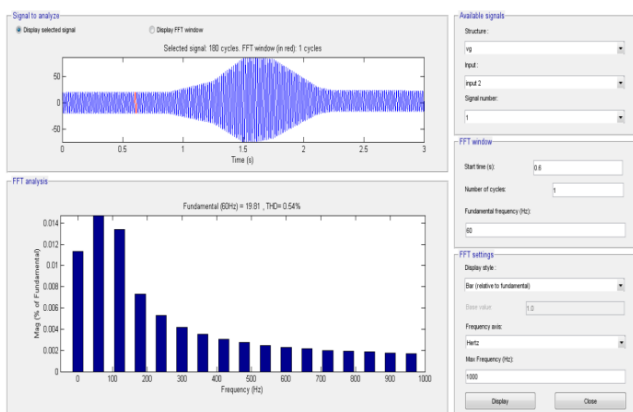

Fig.20 Ig FFT analysis using PI

III. CONCLUSION:

In this paper the design criteria of PV cell, DC/DC converter and grid connected DC/AC bi-directional inverter which belong to the photovoltaic system are determined and Simulink models are established in this study. The control of DC/AC Bi-directional inverter is ensured by using fuzzy logic and PI control. The results of fuzzy logic and PI control were compared. It was seen in the result of simulation that fuzzy logic control is more efficient than PI control, by using fuzzy controllers we can reduce the harmonics.

REFERENCES:

[1] L. H. ROCHA, "Carroeletrico-desafios para suainserc, ao no mercado ~ brasileiro de automoveis," Ph.D. dissertation, Universidade de S´ao Paulo, ~ 2013.

[2] Z. Wan, D. Sperling, and Y. Wang, "China's electric car frustrations," Transportation Research Part D: Transport and Environment, vol. 34, pp. 116-121, 2015.

[3] P. d. A. Sobreira Junior ´ et al, "Conversor cc-cc boost entrelac,adoaplicado no processamento da energia de arranjo solar fotovoltaico," 2011.

[4] R. Kemp, Zero emission vehicle mandate in California: misguided policy or example of enlightened leadership. Edward Elgar: Cheltenham, UK, 2005.

[5] J. F. Mendes and P. Ribeiro, "Electric mobility in Portugal: the beginning," in PLURIS 2012-5o Congresso Luso-Brasileiro para o Planejamento Urbano, Regional, Integrado e Sustentavel'. Universidade de Brasíli. Faculdade de Arquitetura e Urbana, 2012, pp. 1-12.

[6] D. L. Mesquita, A. F. Borges, J. Y. Sugano, and A. C. dos Santos, "O desenvolvimento de processos de inovac,ao sob a ~ otica da teoria dos ´ custos de transac,ao: O caso da tecnologia flex-fuel," ~ RAI Revista de Administrac,ao e Inovac, ~ ao~, vol. 10, no. 1, pp. 119-140, 2013.

[7] N. C. Lima and G. H. S. de Souza, "A demand do etanol e suacaracterizac,ao no mercadobrasileiro de combust ~ ives," Organizac,oes ~ Rurais&Agroindustriais, vol. 16, no. 4, 2015.

[8] M. A. De Brito, L. P. Sampaio, G. Luigi, G. A. e Melo, and C. A. Canesin, "Comparative analysis of mppt techniques for pv applications," in Clean Electrical Power (ICCEP), 2011 International Conference on. IEEE, 2011, pp. 99-104.

[9] D. A. Siqueira and A. A. Siqueira, "Estudo e avaliacao da tecnologia ~ flex fuel," in CONGRESSO NACIONAL DE ESTUDANTES DE ENGENHARIA MECANICA ^ , vol. 11, 2004.

[10] F. L. Bronzatti and A. IAROSINSKI NETO, "Matrizes energeticas ´ no Brasil: cenario 2010-2030," ~ Encontro Nacional de Engenharia de Producao~, vol. 28, 2008.