

Design and Implementation of a Smart Home (Smoke, Fire, Gas and Motion Detector)

PHILIP KPAE, F .O.¹, MACMAMMAH Michael², EZEKIEL Nsikak D.³, WOJI Chigozinum T.⁴, ABUBAKAR Abdullahi⁵ & KPAA Friday O.N.⁶

^{1, 2, 3, 4, 5, 6} Department of Electrical/Electronic Engineering, Ken Saro Wiwa Polytechnic, P.M.20, Bori. Rivers State, Nigeria.

Abstract - Smart Home" is the term normally used to express a dwelling that has appliances, illumination, heating, computers, air conditioning, TVs, entertainment audio, video and camera systems, security systems that are capable of connecting with one another and can be measured remotely by a time schedule, from any apartment in the household, as well as distantly from any locality in the world by phone or internet. This project is aimed to Design a Gas, smoke, fire and motion detector with SMS alarm for house, office, and shop security utilizing uninvolvement derived pyroelectric (PIR) movement locator either the owner is at home or not. The importance of this project is to give an alert when there is leakage of Gas, detection of smoke, fire and motion (intrusion) via SMS. It helps to enhance safety. At the end of this project, the result "fire detected, smoke detected, gas leakage detected, and motion detected was achieved". Smart homes will one day be the manner in which all homes are lived in. This anyway will require some investment. Like the presentation of power in the turn of the century, the shrewd domestic undertaking needs time to develop before it winds up standard. There are, in any case, numerous advantages to owning a smart home because of the security and accommodation it can give.

Key words: Smart Home, GSM Module, Motion Detector, Gas Leakage, Smoke.

1 INTRODUCTION

When one mention smart home, it is not unreasonable to think of high technology devices developed in the silicon age. Smart Home" is the term normally used to express a dwelling that has appliances, illumination, heating, computers, air conditioning, TVs, entertainment audio, video and camera systems, security systems that are capable of connecting with one another and can be measured remotely by a time schedule, from any apartment in the household, as well as distantly from any locality in the world by phone or internet [3]. A growing imperative feature of a smart home is maintenance of the earth's limited properties. An ever increasing number of individuals are getting to be alarm of the capacity to make their homes honestly cunning — and green — by misusing home controllers joined with all home sub-frameworks to expand reserve funds by controlling lighting, window covers, HVAC, water system and by watching utilization [2]. Numerous home controllers have worked in observing frameworks whereby they figure and log use by every single associated gadget, giving the mortgage holder elevated mindfulness and the information to roll out improvements as important. These frameworks can even be gotten to over the Internet from anyplace on the planet so the mortgage holder can change utilization whenever, anyplace.

Actually, the idea of a Smart home framework is one that was concocted long prior. As critical as these improvements where, it was not until 1852 that the main electro-mechanical alarm was imagined. Edwin Holmes was an American innovator from Boston Massachusetts; the alert he formulated was oversimplified however compelling. A solenoid struck a gong when an outing wire was aggravated, in spite of the fact that his caution framework is nothing contrasted with the present contributions except for it was emphatically gotten in its days. Today, Smart home have progressed significantly further. The quick and extended utilization of the web has upset Smart home monstrously, as it has now turned out to be smart.

The smart home system is able to sense its environment and accordingly send alerts to the user on registered device or account. The alert consists of information related to environmental data. This information may include level of different gases in the environment, temperature, humidity, light intensity etc. alert may be sent to user on regular basis at predefined time. Alert may be sent over email, as a text message, through tweets or through any other social media [35].

Powerful home usages accompany self-learning abilities whereby they can take in the mortgage holder's timetables and alter as required. Brilliant homes empowered with lighting control enable property holders to diminish power utilize and along

these lines advantage from vitality related cost reserve funds. Some home robotics frameworks caution the property holder if any movement is identified in the home abide away, and some can call the fire office in the event of up and coming circumstances. Smart home operate with a sensor which is calibrated and programmed to read physical status of the intelligent home and give a feedback to his client [31].

Smart Home is technology to make a house to become intelligent and automated. Usually, that technology has automation systems for lighting, temperature control, security and many other functions [3]. Smart homes can include frameworks that are remote or hardwired. Remote frameworks are taken a toll inviting and simpler to introduce while hardwired frameworks are viewed as more solid and are regularly harder to hack. While hardwired frameworks are additionally more costly than remote alternatives, introducing a hardwired framework can expand the resale estimation of a home. Introducing remote home robotics with highlights, for example, savvy lighting, atmosphere control and security can cost a few thousand dollars.

1.1 SIGNIFICANCE OF A SMART HOME.

The principle significance of Gas, smoke, fire and motion detector is to detect Gas, smoke, fire and motion and caution the vendor by means of SMS. Sensors work when you are not at home or when you tell the framework you are not there. Some security frameworks can record occasions by means of surveillance camera when motion is distinguished.

Gas, smoke, fire and motion detector stand watch, prepared to respond to different circumstances, for example, developments in your lounge room, windows or entryways being open or shut, or a broken window. Gas, smoke, fire and motion detector can;

- Alert you when there is a gas leakage.
- Alert you in case of flame episode
- Alert you in case of smoke
- Triggers an entryway chime when somebody approaches the front entryway
- Alert you when kids enter confined region in the home, similar to storm cellar, exercise center or pharmaceutical bureau
- Save vitality by utilizing movement sensor lightning in empty spaces
- Notify you if pets enter territory where they shouldn't be.

A PIR (passive infrared pyro electric) sensor detects infrared light that is emitted from object on its field of view. PIR sensors differ from other infrared sensors because they can only receive infrared waves. Because all objects emit infrared waves (electromagnetic waves that travels with heat) PIR sensors can only detects object that are in front of them. PIR sensors can detect many things that humans cannot. PIR sensors are used in many applications, such as night vision, motion detection and laser range finding.

2.0 LITERATURE REVIEW

A device which can open and close a garage door remotely doesn't make it system a real Smart Home Installation. Smart Homes begins with simple automation system. Smart is when intelligent functions support your everyday life – whether the functions make you smile through their ingenuity, or just help save you money.

[30], Explains that Smart Home is the term commonly used to define a residence that uses a Home Controller to integrate the residence's various home automation systems. The most popular Home Controllers are those that are connected to a Windows based personal computer (PC) during programming only, and are then left to perform the home control duties on a standalone basis. Integrating the home systems allows them to communicate with one another through the home controller, thereby enabling single button and voice control of the various home systems simultaneously, in preprogrammed scenarios or operating modes.

Internet of Things (IoT) is an emerging technology that is making our world smarter. The idea of connected world cannot be imagined without IoT. An IoT based Smart Home is one such example. In IoT enabled Smart Home environment, various things such as lighting, home appliances, computers, security camera etc. all are connected to the Internet and allowing user to monitor and control things regardless of time and location constraint [35].

2.1 A SMART HOME

Smart home is defined as a home that has programmable electronic controls and sensors that regulate heating, cooling, ventilation, lighting, and appliance and equipment operation in a way that responds to interior climate conditions in order to conserve energy. Smart homes use home automation technologies to provide homeowners with intelligent feedback and information by monitoring many aspects of a home on daily basis [6].

Main elements of smart home:

1. Internal network – wire, cable, wireless.
2. Intelligent control – gateway to manage the systems.
3. Home automation – products within the homes and links to services and systems outside the home.

Smart home is an exceptionally encouraging territory, which has different advantage, for example, giving expanded solace, more prominent wellbeing and security, a more reasonable utilization of vitality and different assets along these lines adding to a critical funds [33].

The Smart home known as house autionation, with utilization of new innovation, to make the local exercises more advantageous, agreeable, secure and sparing [38].



(Fig 2.0: Interface of a smart home. Retrieved 12/5/18)

(Source: <http://smarthomeenergy.co.uk>)

An automated device has ability to work with versatility, diligence and with lowest error rate. The idea of home automation system is a significant issue for researchers and home appliances companies. Automation system not only helps to decrease the human labor but it also saves time and energy. Early home automation systems were used in labor saving machines but

nowadays its main objective is provide facilities to elderly and handicapped people to perform their daily routine tasks and control the home appliances remotely [24].

A Smart Home" is one where different "Smart" gadgets are coordinated together making a situation that can be robotized and effortlessly controlled. Smart devices are commonly IP empowered and controllable by an application [3]. Normal gadgets in an "Associated Home" include:

- ❖ Smart indoor regulators
- ❖ Smart speakers
- ❖ Smart lights
- ❖ Smart cameras and additionally, sensors, locks, shades, carport entryways, and so forth. Sadly the vast majorities of these items have their own particular application and don't coordinate well with others.

A research work proved that Bluetooth system is faster than wireless and GSM systems. Bluetooth technology has ability to transmit data serially up to 3 Mbps within a physical range of 10m to 100m depending on the type of Blue tooth device [24].

Propelled brilliant homes may incorporate a few other "smart" segments. For instance, understanding blinds can close to keep the house cool or open to permit more warmth in through the windows. A few blinds can be modified to open gradually toward the beginning of the day to enable you to wake up to common lighting.

[40], Smart Home System is an intelligent home network combined with advanced communication technology, sensing control technology and some embedded systems to carry out effective control and information exchange. While currently the Smart Home System is mainly used in a number of upscale communities and has not been widely used for ordinary people.

A smart home also referred to as a connected home or e-Home is an environment for living that has highly advanced automatic systems. A smart home appears "intelligent" because its daily activities are monitored by a computer. A smart home consists of many technologies via home networking for improving quality of living [8]. A smart home is a place that has highly advanced automatic systems for controlling and monitoring lighting and temperature, home appliances, multi-media equipment, and security systems and many other functions. IOT plays an important role in building smart home [35].

It is true that to say that smart home is the utilization of control frameworks and data innovations to lessen the requirement for human work in the generation of products and ventures. Smart home-empowered gadgets can incorporate devices like coolers, clothes washers, dryers, and toaster stoves, and in addition warming, ventilating, cooling units and lighting gadgets. A few cases of smart home-empowered electronic gadgets are sound and video stimulation frameworks, camera and security frameworks, and PCs, workstations and different hardware cell phones.

2.2 FUNCTIONS OF SMART HOME

Smart home offers a range of options and application to its users. It does not only provide comfort, but also provide security and safety to it client. Smart home may function in so many ways which include;

1. Adaptability for new gadgets and apparatuses. Smart home frameworks have a tendency to be magnificently adaptable with regards to the convenience of new gadgets and machines and other innovation. Regardless of how best in class your apparatuses appear to be today, there will be more up to date, more amazing models created over the long prior [13].
2. Amplifying home security. When your fuse security and observation includes in your smart home system, your home security can rise. There are huge amounts of alternatives here - just a couple of dozen of which are as of now being investigated. For instance, smart home mechanization frameworks can associate movement finders, observation cameras, computerized entryway locks, and other substantial safety efforts all through your home so you can initiate them from one cell phone before going to bed. You can likewise get security cautions on your different gadgets relying upon the season of day an alarm goes off, and screen exercises continuously whether you're in the house or most of the way around the world [37].
3. Remote control of home capacities. Try not to think little of the energy of having the capacity to control your home's capacities from a separation. On an outstandingly hot day, you can arrange your home to end up cooler in simply

enough time before you return home from work. In case you're in a rush to eat began yet you're still at the store, you can have your stove begin to preheat while you're still on your way home. You can even verify whether you cleared out the lights on, who is at your front entryway, or ensure you killed every one of your media while you're away [19].

4. *Control:* This function of smart home allows user to control different activities. The activities may include switching on/off lights, air-conditioner, and appliances; lock/unlock doors, open/close windows and doors and many more. User can control things from same place or from remote location. This function even allows user to automate activity such as automatically switch on/off air-conditioner when room temperature high/low [35].
5. Enhanced machine usefulness. Smart homes can likewise enable you to run your machines better. A smart TV will enable you to discover better applications and channels to find your most loved programming. A smart stove will help you with cooking your chicken to flawlessness - while never stressing over overcooking or undercooking it. A smart planned home theater and sound framework can make dealing with your motion picture and music gathering easy while engaging visitors [8].

2.3 CLASSIFICATION OF SMART HOME

From the figure below (fig. 2.1), Smart home can be classified according to its functional purpose which constitutes an important interdisciplinary research area of PC designing that is set at the meeting of PC systems [7].

Thus, smart home is classified as follows;

- ❖ A smart home that contains an arrangement of home apparatuses.
- ❖ They are electric and electronic indecencies that is full of a few capacities in the house for the prosperity of the house holders, including for instance, washing and cooking machines, iceboxes, heaters, thermometers, lighting framework, electrical plugs, vitality meters, smoke indicators, TVs, amusement supports and other excitement gadgets, windows and entryways controllers, aeration and cooling systems, camcorders, sound detectors.
- ❖ Their capacities can be generally isolated into sensors, actuators or both [2].

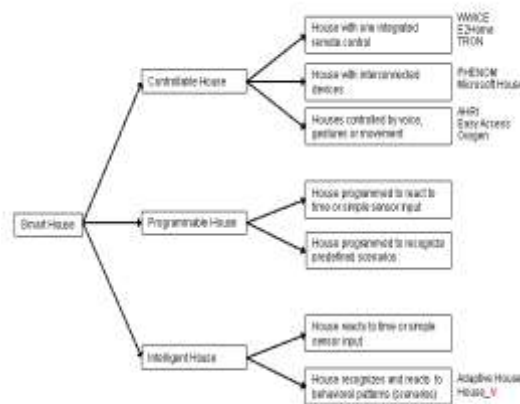

Fig. 2.1: classification of smart home, retrieved 14/5/2018

(Sources: <http://smarthomeenergy.co.uk>)

A Control System that consolidates human with programming based control by utilizing the data provided by the sensors and the directions sent to actuators so as to accomplish at least one abnormal state objective or elements of the smart home, as required by home holders.

2.4 STRUCTURE OF SMART HOME

As earlier said, a Smart Home is made out of the accompanying parts: Home Automation System, Control System and Home Automation Network [5], [10], [15] [20].

The Home Automation System may contain a huge variety of home machines that are picked relying upon specific applications. Smart home is comprised of three essential parts [23], [24], [30]:

- (i) The physical part that speaks to the question in reality;
- (ii) The equipment framework that is vital for attributing brilliant abilities to the protest;
- (iii) The product layer that really gives the Smart capacities of the object.

The Home Automation Network is represented by physical innovation and correspondence conventions. Home Network advances are ordered in three primary classes: Power-line, bus-line and remote.

- ❖ The power-line uses a medium of cable to regulate signal.
- ❖ Bus-line home systems utilize a different physical media for transporting electrical signals.
- ❖ Remote home systems utilize remote correspondences, for instance infrared or radio frequency, and have the upside of being more attractive for the clients, as they don't require any cabling.

2.5 GAS LEAK DETECTOR

Gas leakages can cause real accident bringing about both human wounds and money related disasters. To maintain a strategic distance from such circumstances, a lot of effort has been given to the improvement of solid methods for recognizing gas spillage.

Gas is a flammable mixture of hydrocarbon gases used as a fuel in heating appliances and vehicles. Varieties of LPG bought and sold include mixtures that are primarily propane (C₃H₈), primarily butane (C₄H₁₀) and, most commonly includes both propane and butane, depending on the application [26].

A gas detector is a device that detects the presence of gases in an area, often as part of a safety system. This type of equipment is used to detect a gas leak or other emissions and can interface with a control system so a process can be automatically shut down. A gas detector can sound an alarm to operators in the area where the leak is occurring, giving them the opportunity to leave. This type of device is important because there are many gases that can be harmful to organic life, such as humans or animals.

It can be used to detect combustible, flammable and toxic gases, and oxygen depletion. This type of device is used widely in industry and can be found in locations, such as on oil rigs, to monitor manufacture processes and emerging technologies such as photovoltaic.

The gas leakage alarm circuit operates on a 9V PP3 battery. Zener diode ZD1 is used to convert 9V into 5V DC to drive the gas sensor module. A preset in the module is used to set the threshold. Interfacing with the sensor module is done through a 4-pin SIP header.

Whenever there is Gas concentration of 1000 ppm in the area, the OUT pin of the sensor module goes high. This signal drives timer IC 555, which is wired as an astable multivibrator. The multivibrator basically works as a tone generator.

Output pin 3 of IC 555 is connected to LED1 and speaker-driver transistor SL100 through current-limiting resistors R5 and R4, respectively. LED1 glows and the alarm sound to alert the user of gas leakage. The pitch of the tone can be changed by varying preset VR1. It Uses a suitable heat-sink for transistor SL100 [36]. They may be used in firefighting. Gas leak detection is the process of identifying potentially hazardous gas leakag by sensors. These sensors usually employ an audible alarm to alert people when a dangerous gas has been detected. Exposure to toxic gases can also occur in operations such as painting, fumigation, fuel filling, construction, excavation of contaminated soils, landfill operations, entering confined spaces, etc. Common sensors include combustible gas sensors, photoionization detectors, infrared point sensors and ultrasonic sensors and electrochemical gas sensors, and semiconductor sensors [36].

2.6 COMPONENT OF A GAS LEAK DETECTOR

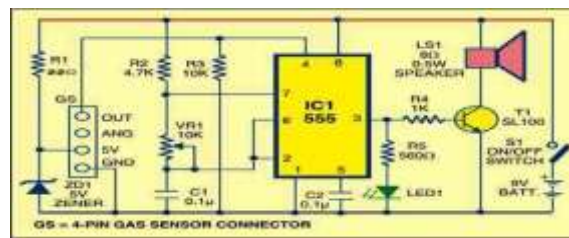

Fig 2.2: Gas leak detector schematic

(source: <http://electroschmatic.com>, retrieved 13/5/2018)

As seen from the circuit above, the gas leak detector uses SEN-1327 gas sensor module, a preset in the module is utilized to set the limit. Interfacing with the sensor module is done through a 4-stick SIP header. Stick points of interest of the gas sensor module are appeared in the Figure. A MQ-6 gas sensor is utilized as a part of the gas sensor module. The sensor can likewise be utilized to recognize ignitable gases, particularly methane. Other component used are, resistors, transistors, LEDs, diodes, speakers, capacitors, switches etc.

2.7 CAUSES OF GAS LEAKAGE

Gas leaks in the home are usually the result of poorly fitted, badly maintenance or faulty appliances like cylinders, boilers and cookers.

Numerous machines in your home may utilize flammable gas or propane to make warm, including water radiators, dryers, stoves and chimneys. As these apparatuses become more established, the seals that associate the channeling can consume and cause a gas spill. Apparatuses such like stoves or clothing machines that utilization a start to light the gas for utilize can end up flawed and not touch off the gas. On the off chance that somebody neglects tighten the gas handle; the gas can escape into the home [14].

2.8 PREVENTION OF GAS LEAKAGE

It is far simpler to manage a gas spill by preventing it from happening in any case. Your first line of guard is with your family apparatuses.

Continuously ensure they are introduced by an authorize Gas Safe Register specialist, and ensure you check them all the time for indications of wear and tear.

In like manner, on the off chance that they do require upkeep, ensure your specialist is enrolled. To keep away from carbon monoxide harming, introduce a capable of being heard carbon monoxide caution in your home. These are shoddy to buy from DIY stores and look simply like smoke alerts. Ensure they are introduced in an open space like a foyer, and change the batteries yearly [25].

2.9 MOTION DETECTOR

Different security frameworks can be discovered introduced in homes and workplaces alike. For instance, Closed-circuit Television (CCTV) is a famous innovation utilized widely with the end goal of home and office security and observation. Albeit, such frameworks may offer a few merits as minimal effort and relative simplicity of establishment, in any case they additionally have some real downsides [21]. Motion indicator or interloper identifier, giving spotlight on the few innovations connected, incorporate remote transmission and gathering of caution message and charge through GSM/GPRS, TCP/IP and it includes advancement of online gatecrasher alarm observing and control equipment and programming [28].

The home automation refers to household condition that enhances the nature of inhabitant's life by encouraging an adaptable, agreeable, solid and safe condition. With fast improvement in PC and system, the web base home security has propelled a ton

in inhabitant regions [34]. The motion detector provides ideal solution to the problems faces by home owner in daily life [32]. Due to the expanding fast development of individuals, security innovation is required which has a normal for versatile innovation as far as getting data effortlessly and rapidly [11].

3.0 IMPLEMENTATION OF MOTION DETECTOR

By utilizing a blend of sensors and chip that are portrayed in the accompanying areas, this framework can consolidate some critical highlights into its working. These are clarified beneath:

This framework utilizes shrewd sensors to screen the nearness of trespassers and conceivable interlopers close to the homes section focuses such as entryway, windows and so forth. This element empowers the framework to begin recording video just when it sees the risk. Consequently, a client does not need to look over hours of unimportant video information. The motion detection system is about firewall. The fire wall protects an organization from malicious attack from the internet and the motion detector detect if someone tries to access in through the firewall or manages to break in the firewall security [1].

This spares time as well as abatements the general memory and preparing power prerequisites Furthermore, the executed framework utilizes the locally accessible Wireless LAN (WLAN) network to send an email to the client with the video recorded as a connection. Therefore no extra equipment establishments are required to caution the client [21].

3.1 SMOKE DETECTORS

Smoke is a visible suspension of carbon or other particles in the air which emitted from a burning substance. It is commonly an unwanted by-product of fires and fireplaces but may also be used for pest control, communication as smoke signals, defense as smoke-screen and inhalation of tobacco or other drugs. Smoke inhalation is the primary cause of death in victims of indoor fires. Many compounds of smoke from fires are highly toxic and poisoning. The most dangerous is the carbon monoxide which leading to carbon monoxide poisoning. Those who inhale large amount of smoke quickly lead to incapacitation and loss of consciousness [28].

Smoke Detector is a sensitive device against the smoke. Whether using ionization or photoelectric technique, the presence of the smoke is detected. The components used in this project are a photoelectric smoke detector, encoder, decoder, transmitter, receiver and siren. The relay is built in the smoke detector. When the smoke is detected, the relay is triggered [28].

Smoke detectors, these devices are one of the best early-warning devices of a fire. They are designed to sense low levels of smoke and sound an alarm. Some smoke alarms are what are known as "single station," or stand-alone devices. If they go into alarm, only the one detector is activated, alerting people right around it. Some detectors may be connected to the building's fire alarm system. When this detector senses smoke, it may either sound an alarm in the room, or send a signal to the building fire alarm system. It is important that smoke alarms are located in areas where they cannot be set off accidentally by steam from showers or from cooking smoke. Smoke detectors have two main types: Photoelectric Smoke Detectors, and Ionization Smoke Detectors [13].



Fig. 2.3: Design of a Smoke Detector)

(Source: explainthatstuff.com retrieved 14/5/2018)

3.2 COMPONENT OF SMOKE DETECTOR

An ICSD smoke detector is composed of a housing made of polyvinylchloride or poly-styrene plastic, a small electronic alarm horn, a printed circuit board with an assortment of electronic components, and a sensing chamber and reference chamber, each containing a pair of electrodes and the radioactive source material such as;

- Alarm Initiating Devices
- Alarm Notification Devices
- Smoke Alarm Control Panel (FACP)
- Backup Power Supply
- Remote Control & Display Panels
- Sprinkler Systems.

3.3 FIRE DETECTOR

A fire detector is a sensor designed to identify and react to the immediacy of a fire or fire, permitting fire recognition. Reactions to a recognized fire rely upon the design establishment, yet can incorporate sounding an alert, deactivating a fuel line, (for example, a propane or a flammable gas line), and actuating a fire concealment framework. The fire detector raises alarm whenever fire is detected at any place [22]. Thermistor is utilized to sense temperature of the home, when the temperature of the room increment past the reference temperature. it detects that the temperature of the home has expanded. when it detects warm, it change over temperature to voltage and the flag from it is little along these lines its intensified through the intensifier, LM385 and its opened up twice, before it is sent to the principle board microcontroller [27].

Automatic fire alarm system is a typical multi-sensor type of event-driven wireless sensor network (WSN), but with its special requirements [4].

- ❖ System reliability, credibility, we must consider the indoor multi-path scattering, echo, interference, interruption, to deal with collision detection;
- ❖ System works a minimum of 5 years life cycle;
- ❖ Switchboard and must be two-way communication between detectors;
- ❖ Alarm signal transmission time must be within 10 seconds;
- ❖ System interference and failure detection time to less than 100 to reflect seconds.



(Fig. 2.4 formation of fire)

(Source: smarthomeenergy.co.uk, retrieved 15/5/2018)

The primary purpose of fire alarm system is to provide an early warning of fire so that people can be evacuated & immediate action can be taken to stop or eliminate of the fire effect as soon as possible. Alarm can be triggered by using detectors or by manual call point (Remotely). To alert/evacuate the occupants siren are used [13].

A fire alert framework has various gadgets cooperating to identify and caution individuals through visual and sound machines when smoke, fire, carbon monoxide or different crises are available. Fire detector are designed to respond at an early stage to one or more of the four major characteristics of combustion, heat, smoke, flame or gas [17]. These cautions might be enacted naturally from smoke sensors, and heat identifiers or may likewise be actuated by means of manual fire alert initiation gadgets, for example, manual call focuses or pull stations. A fire detector is usually implemented as a smoke sensor due to its early fire detection capability, fast response time and relatively low cost [16].

3.4 CLASSES OF FIRE

Combustible materials, when burning, do not always lead to fires with the same characteristics. We all know that the cooking gas, butane, doesn't burn like a match, not only by the colour of the flame as in the amount of heat released (google.com). The study of various fuels has led to the standardization of the fuels and fires, creating four classes: **Class A** - Fires arising from the combustion of solid materials. Ex.: Wood, Fabric, Rubber. **Class B** - Fires arising from the combustion of liquid materials. Ex.: Petrol, Alcohol, Oil... **Class C** - Fires that result from combustion of gases. Ex.: Butane, Propane, Acetylene. **Class D** - Combustion of metals. Ex.: Sodium, Potassium, Magnesium.

2.5.2 CAUSES OF FIRE

The dominant part of flames took care of by safeguard administrations are caused in non-private structures, with a significant number of these being recorded as working environment episodes. There are numerous components that can improve the probability of a fire being caused. Notwithstanding you can take measures to stay away from flame in home and guarantee the wellbeing of your family. The following are the absolute most normal reasons for house flames, and a few hints to play it safe (realinsurance.com).

- Cooking Equipment
- Heating
- Smoking in bedrooms
- Electrical Equipment.
- Candles
- Curious Children
- Faulty Wiring
- Barbeques
- Flammable Liquids
- Lighting.

3.5 TYPES OF FIRE

There are four different types of fire:



Class A fires involve solid materials of an organic nature such as wood, paper, cloth, rubber and plastics that do not melt.

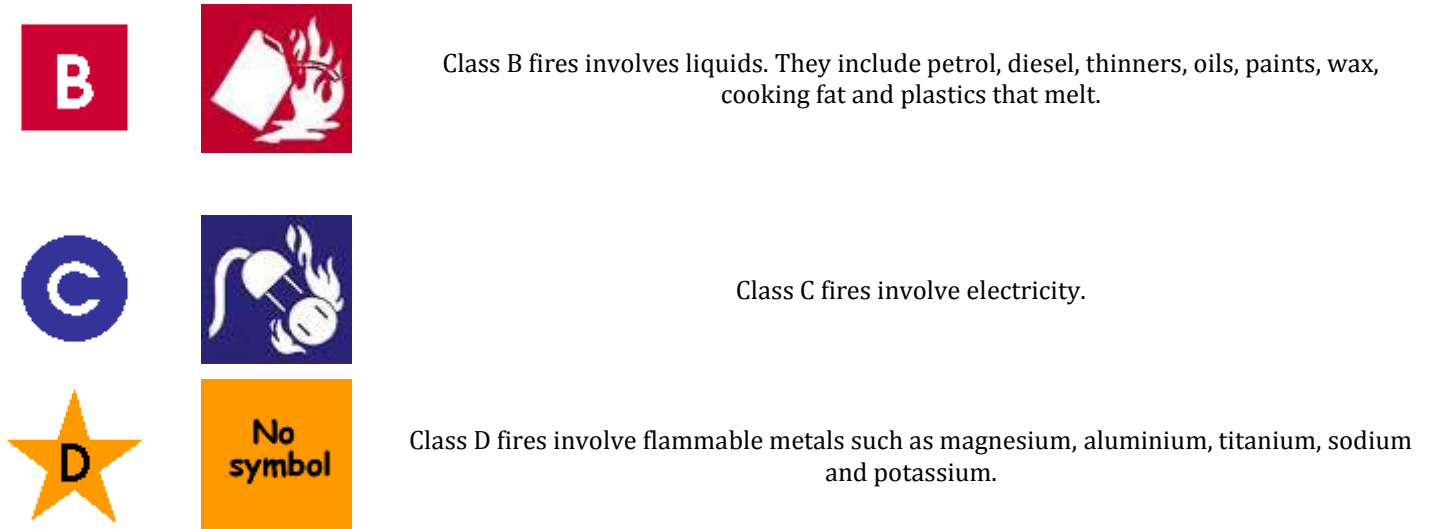

Fig 2.5: Classes of fire symbols.

3.7 PREVENTION OF FIRE

The Fire Prevention Triangle - Heat, Oxygen and Fuel

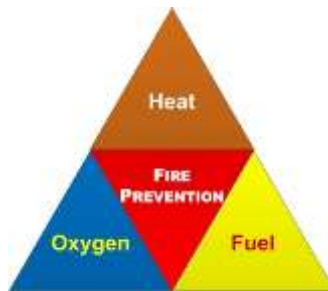

Fig. 2.5.1: Fire triangle

A fire needs three elements - heat, oxygen and fuel. Without heat, oxygen and fuel a fire will not start or spread. A key strategy to prevent fire is to remove one or more of heat, oxygen or fuel. The risk assessment should include detail on all three elements to minimize the risk of a fire starting/spreading.

3.6 GSM MODULE

A GSM module or a GPRS module is a chip or circuit that will be used to establish communication between a mobile device or a computing machine and a GSM or GPRS system. The modem (modulator-demodulator) is a critical part here.

GSM Module encodes and decodes signals sent to and from the network servers. Modems are frequently associated with telephone systems, but wireless modems are used with computers and also with communication mediums. Wireless modem interfaces include PCMCIA, Compact Flash, USB and Serial Port. GSM is used as a communication medium to help establish connection in places where there may not be proper internet connectivity [31].

The GSM Module system is battery powered which made home automation system safer from internet hacks. [34]. A GSM modem is a network device which connects to a GSM network. A GSM modem is a specialized type of modem which accepts a SIM card, and operates over a

Subscription to a mobile operator, just like a mobile phone, it can be used for sending and receiving SMS [13].

These modules consist of a GSM module or GPRS modem powered by a power supply circuit and communication interfaces (like RS-232, USB 2.0, and others) for computer. A GSM modem can be a dedicated modem device with a serial, USB or Bluetooth connection, or it can be a mobile phone that provides GSM modem capabilities [29].

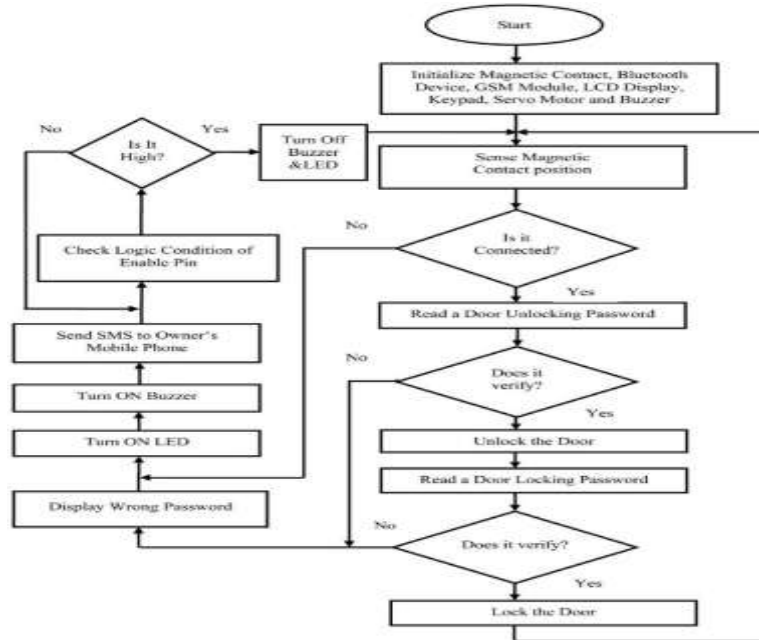

(Figure 2.6: Program flow chart of the proposed home security system).

(Source: electroschmatic.com, retrieved 18/5/2018).

The program flow chart of the proposed home security system has been shown in Fig 2.6, which explains the whole software design procedures. Software Code Vision AVR is used as a compiler for designing the program in C- Language. The proper instructions perform the desired function sequentially according to the flow chart. At first, the program initializes all peripheral devices (Magnetic Contact, Bluetooth Device, GSM Module, LCD Display, Keypad, Servo Motor and Buzzer).



Fig 2.6.1 GSM Module

(Source: electroschmatic.com. retrieved 15/5/2018)

3.8 APPLICATION OF GSM MODULE

A GSM module is a gadget simply like a telephone, and obviously is needs a SIM (what GSM does not?!). With the present GSM modules you can do anything a telephone can do, utilize it for information exchange and so forth. This zone is called M2M -

Machine 2 (to) Machine interchanges. Some famous module producers are Motorola, Siemens and Nokia. There are obviously some more. Some come in implanted OEM module composes while others are in an outside case. GSM modem can be dedicated modem device with serial, USB or Bluetooth connection, or mobile phone that provided GSM modem capabilities [27].

3.9 INTERFACE OF GSM MODULE

The figure below demonstrates how to interface the GSM with microcontroller. The GSM module is impart the microcontroller with cell phones through UART. To impart over UART or USART, we simply require three fundamental signs which are to be specific, RXD (get), TXD (transmit), GND (shared view).

GSM modem interfacing with microcontroller for SMS control of modern supplies. The sending SMS through GSM modem when interfaced with microcontroller or PC is substantially more straightforward as contrasted and sending SMS through UART.

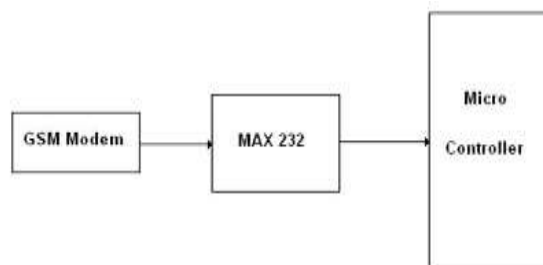

Fig 2.6.2: Interface of GSM Module

(Sources: electroschmatic.com, retrieved 16/5/2018).

The transmit flag of serial port of microcontroller is associated with transmit flag (TxD) of the serial interface of GSM Modem while get flag of microcontroller serial port is associated with get flag (RxD) of serial interface of GSM Modem.

The SMS message in content mode can contain just 140 characters and no more. It relies on the measure of data gathered from GPS Engine that you require at the base station for following vehicle or individual.

4.0 ARCHITECTURE OF GSM MODULE

A GSM module comprises of the following parts:

- ❖ A Mobile Station: It is the cell phone which comprises of the handset, the show and the processor and is controlled by a SIM card working over the system.
- ❖ Base Station Subsystem: It goes about as an interface between the versatile station and the system subsystem. It comprises of the Base Transceiver Station which contains the radio handsets and handles the conventions for correspondence with mobiles. It additionally comprises of the Base Station Controller which controls the Base Transceiver station and goes about as an interface between the portable station and versatile exchanging focus.
- ❖ System Subsystem: It gives the fundamental system association with the portable stations. The fundamental piece of the Network Subsystem is the Mobile Service Switching Center which gives access to various systems like ISDN, PSTN and so forth. It likewise comprises of the Home Location Register and the Visitor Location Register which gives the call steering and wandering abilities of GSM. It additionally contains the Equipment Identity Register which keeps up a record of all the versatile types of gear wherein every portable is recognized by its own IMEI number. IMEI remains for International Mobile Equipment Identity.

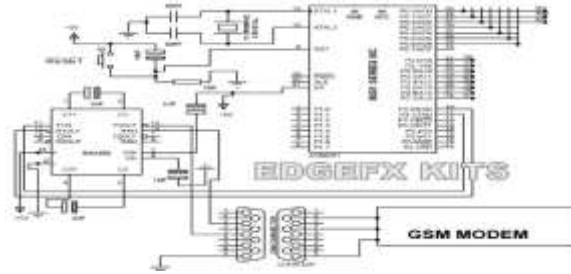

Fig 2.6.3: Working principle of a GSM module

(Source: <https://www.elprocus.com>, retrieved 16/5/2018).

4.1 WORKING PRINCIPLES OF GSM MODULE

From the above circuit, a GSM modem properly interfaced to the MC through the level shifter IC Max232. The SIM card mounted GSM modem after getting digit charge by SMS from any wireless send that information to the MC through serial correspondence. While the program is executed, the GSM modem gets charge 'STOP' to build up a yield at the MC, the contact purpose of which are utilized to incapacitate the start switch. The charge so sent by the client depends on a suggestion got by him through the GSM modem 'Caution' a customized message just if the information is driven low. The total activity is shown more than 16x2 LCD show (<https://www.elprocus.com>).

GSM module allows correspondence anyplace, whenever, and with anybody. The practical design of GSM module utilizing wise systems administration standards, and its philosophy, which gives the improvement of GSM is the initial move towards a genuine individual correspondence framework that enough institutionalization to guarantee similarity.

5.0 DESIGN CONSIDERATION

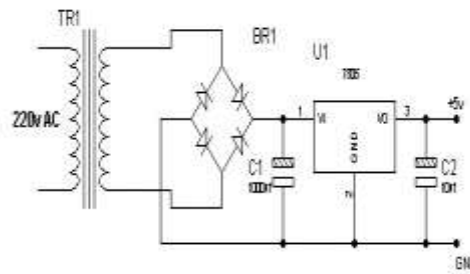

FIG 3.1 Circuit Diagram

Source: electroschmatic.com, retrieved 2/7/2018

Controlling your home with a cell phone has been workable for quite a while. In any case, for the past years there has been a pile of new innovations that offer us the opportunity to make our own smart home which can be controlled from our telephone without the requirement for a degree in electronic plan. With smart remote controls, you can be in entire control of your home regardless of where you are.

In designing a smart home, the following priority has to be considered;

- Security
- Safety

- Control
- Detection

5.2 SYSTEM ARCHITECTURE

The smart home architecture comprises mainly two components, the hardware interface and the software control components.

❖ THE POWER SUPPLY UNIT

This is a simple approach to obtain a 5V DC power supply using a single circuit. The circuit uses 7805 for obtaining the required voltages. The AC mains voltage is stepped down by the transformer T1, rectified by bridge B1 and filtered by capacitor C1 to obtain a steady DC level. The IC (7805) regulates this voltage to obtain a steady 5V DC at its output. In this way, a 5V DC is obtained.

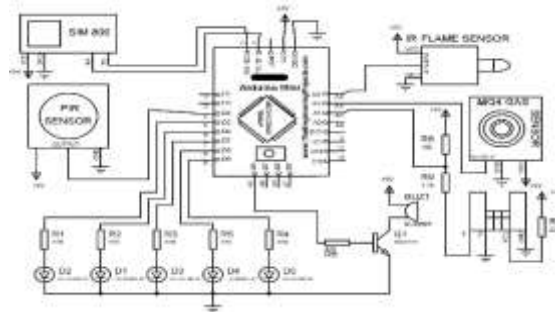

Fig 3.1 Power supply circuit.

5.3 DESIGN CONSTRUCTION

The entire device is built around the Arduino pro-mini which utilizes the atmega 328p microcontroller.

The following steps were considered to complete the design construction of this research:

Step 1: The SIM800L GSM Module is connected to the RX, TX Pin.



Fig 3.2 SIM800L GSM Module



Fig 3.3: Connection of the GSM module

Step 2: The motion detector sensor (PIR Sensor) is connected to the digital pin 4 of the microcontroller.

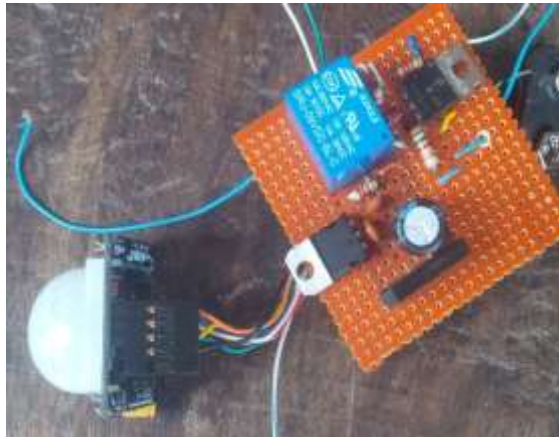

Fig 3.4: PIR Sensor



Fig 3.5: connection of the PIR to the packaging box

Step 3: The IR flame sensor is connected to analogue pin 3 of the microcontroller.



Fig 3.6: IR flame sensor



Fig 3.7: IR sensor connected to packaging box.

Step 4: The MQ4 Gas sensor is connected to the pin 2 of the microcontroller.



Fig 3.8: MQ4 Gas sensor



Fig 3.9: MQ4 Gas sensor connected to the packaging box.

Step 5: The MQ2 Smoke sensor is connected to the pin 1 of the microcontroller.



Fig 3.10: MQ2 Smoke sensor



Fig 3.11: MQ2 Smoke sensor connected to the packaging box.

Step 6: The buzzer is connected to the digital pin 6 through transistor Q1.

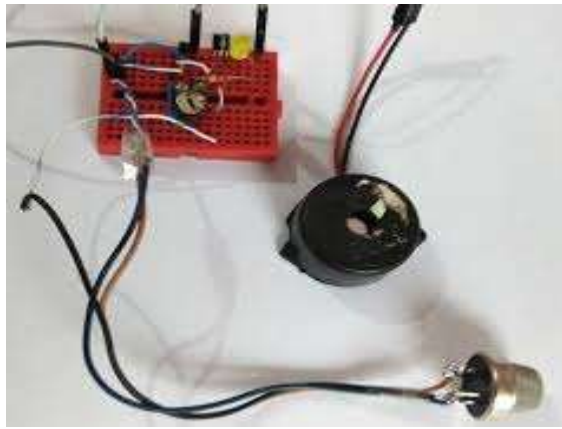

Fig 3.12: image of the buzzer

Step 7: The smoke detector LED is connected to the digital pin 5 of the microcontroller.

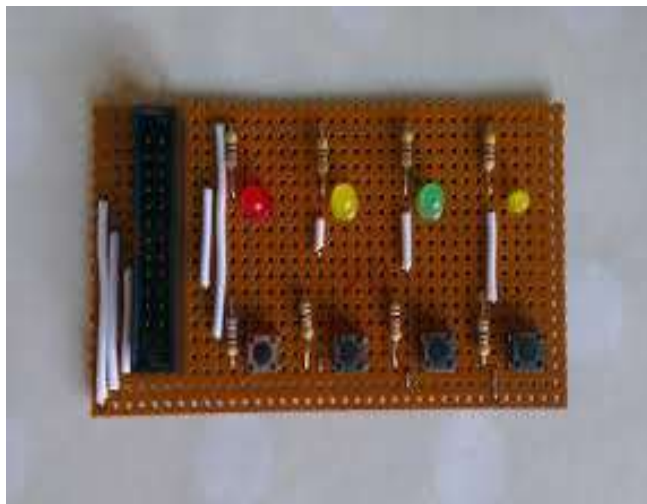

Fig 3.13: connections of the LED

Step 8: The Gas indicator LED is connected to the digital pin 6 of the microcontroller.

Step 9: The Fire indicator LED is connected to the digital pin 7 of the microcontroller.

Step 10: The Motion indicator LED is connected to the digital pin 8 of the microcontroller

Step 11: The Power indicator LED is connected to the digital pin 9 of the microcontroller

Step 12: The Vcc terminals of the microcontroller and sensors were connected to the 5V terminal of the power supply.



Fig 3.13: connection of the Vcc terminal

Step 13: The GND (Ground) terminals of the microcontroller and sensors were connected to the GND terminals of the power supply.

Step 14: The C Program is loaded into the microcontroller.



Fig 3.14: Packaging of all components

Step 15: The final step was to couple the circuit.



Fig 3.15: Final packaging.

3.5 COST ANALYSES

SN	COMPONENT	QUANTITY
1	Arduino promini	1
2	SIM 800 GSM Module	1
3	Mq4 Gas Sensor	1
4	IR Flame Sensor	1
5	MQ4 Smoke Sensor	1
6	PIR Sensor	1
7	Buzzer	1
8	Transistor	1
9	LEDs	6
10	Resistors	7
11	Step down transformer	1
12	Bridge rectifier	1
13	Capacitors	2
14	Voltage Regulator 7805	1
15	Packaging box	1
16	Connection wires	Several
17	Vero board	1
18	Soldering Lead	1

6.0 RESEARCH PRESENTATION

The research was presented on a trip board which is a widely-used type of electronic prototyping board characterized by a 0.1 inch (2.5mm) regular grid of holes, with wide parallel strips of copper cladding running in one direction all the way across the side of the board it is usually known by the name "Vero board" which is a trade mark in the UK, of British company Vero technologies limited and pixel print limited Canada. in using the board, breaks are used in the tracks, usually round holes to divide the strips into multiple electrical nodes. With care, it is possible to break between holes to allow for components that have two pin rows only in one position apart such as twin row header for IDCs. The components are mounted as shown in fig 1.0. the components and links where made properly to form electrical circuit.

6.2 TESTING AND RESULT

The circuit was tested as it was being developed. During the construction, the following faults were initially encountered and corrected as explained further below;

- Microcontroller not functioning.
- Mal-functioning of the alarm system.

❖ MICROCONTROLLER NOT FUNCTIONING

The system did not work at all when it was connected to the voltage source at the first time of testing the project. The microcontroller had to be re-programmed being the heart of the project and every other circuit depending on it to function. The problem was solved after the re-programming of the microcontroller was done.

The program is as follows:

```
#include <SoftwareSerial.h>

SoftwareSerial mySerial(11, 10);

int smoke = A3;

int fire = A1;

int gas = A2;

int motion = A0;

int active_led = 5;

int smoke_led = 8;

int gas_led = 6;

int motion_led = 7;

int fire_led = 4;

int buzzer = 9;

int sensor_smoke;

int sensor_gas;

int sensor_motion;

int sensor_fire;

int sms_count=0;

void setup()

{

pinMode (smoke, INPUT);

pinMode (fire, INPUT);

pinMode (gas, INPUT);

pinMode (motion, INPUT);

pinMode (active_led, OUTPUT);

pinMode (smoke_led, OUTPUT);

pinMode (gas_led, OUTPUT);
```

```
pinMode (motion_led, OUTPUT);
pinMode (fire_led, OUTPUT);
pinMode (buzzer, OUTPUT);
Serial.begin(9600);
mySerial.begin(9600);
digitalWrite (active_led, LOW);
digitalWrite (smoke_led, LOW);
digitalWrite (fire_led, LOW);
digitalWrite (gas_led, LOW);
digitalWrite (motion_led, LOW);
digitalWrite (buzzer, LOW);
Serial.println("AT+CNMI=2,2,0,0,0" );
delay(500);
Serial.println("AT+CMGF=1");
digitalWrite (active_led, HIGH);
}
void loop()
{
//smoke detection section//
if(digitalRead(smoke)==LOW)
if(digitalRead(gas)==HIGH)
if(digitalRead(fire)==HIGH)
if(digitalRead(motion)==LOW)
while(sms_count<1)
{
digitalWrite (smoke_led,HIGH);
digitalWrite (fire_led, LOW);
digitalWrite (gas_led, LOW);
digitalWrite (motion_led, LOW);
```

```
digitalWrite (buzzer, HIGH);
sms_count=1;
}else{
sms_count=0;
}
//gas detection section//
{
if(digitalRead(smoke)==HIGH)
if(digitalRead(gas)==LOW)
if(digitalRead(fire)==HIGH)
if(digitalRead(motion)==LOW)
while(sms_count<1)
{
digitalWrite (smoke_led,LOW);
digitalWrite (fire_led, LOW);
digitalWrite (gas_led, HIGH);
digitalWrite (motion_led, LOW);
digitalWrite (buzzer, HIGH);
sms_count=1;
}else{
sms_count=0;
}
//fire detection section//
{
if(digitalRead(smoke)==HIGH)
if(digitalRead(gas)==HIGH)
if(digitalRead(fire)==LOW)
if(digitalRead(motion)==LOW)
while(sms_count<1)
```



```
{
digitalWrite (smoke_led,LOW);
digitalWrite (fire_led, HIGH);
digitalWrite (gas_led, LOW);
digitalWrite (motion_led, LOW);
digitalWrite (buzzer, HIGH);
sms_count=1;
}else{
sms_count=0;
}
//motion detection section//
{
if(digitalRead(smoke)==HIGH)
if(digitalRead(gas)==HIGH)
if(digitalRead(fire)==HIGH)
if(digitalRead(motion)==HIGH)
while(sms_count<1)
{
digitalWrite (smoke_led,LOW);
digitalWrite (fire_led, LOW);
digitalWrite (gas_led, LOW);
digitalWrite (motion_led, HIGH);
digitalWrite (buzzer, HIGH);
sms_count=1;
}else{
sms_count=0;
}
//smoke, gas, fire and motion detection section//
{
```

```
if(digitalRead(smoke)==LOW)
if(digitalRead(gas)==LOW)
if(digitalRead(fire)==LOW)
if(digitalRead(motion)==HIGH)
while(sms_count<1)
{
digitalWrite (smoke_led,HIGH);
digitalWrite (fire_led, HIGH);
digitalWrite (gas_led, HIGH);
digitalWrite (motion_led, HIGH);
digitalWrite (buzzer, HIGH);
sms_count=1;
}else{
sms_count=0;
}
//smoke and gas detection section//
{
if(digitalRead(smoke)==LOW)
if(digitalRead(gas)==LOW)
if(digitalRead(fire)==HIGH)
if(digitalRead(motion)==LOW)
while(sms_count<1)
{
digitalWrite (smoke_led,HIGH);
digitalWrite (fire_led, LOW);
digitalWrite (gas_led, HIGH);
digitalWrite (motion_led, LOW);
digitalWrite (buzzer, HIGH);
sms_count=1;
```

```
}else{
sms_count=0;
}
//smoke and fire detection section//
{
if(digitalRead(smoke)==LOW)
if(digitalRead(gas)==HIGH)
if(digitalRead(fire)==LOW)
if(digitalRead(motion)==LOW)
while(sms_count<1)
{
digitalWrite (smoke_led,HIGH);
digitalWrite (fire_led, HIGH);
digitalWrite (gas_led, LOW);
digitalWrite (motion_led, LOW);
digitalWrite (buzzer, HIGH);
sms_count=1;
}else{
sms_count=0;
}
//smoke and motion detection section//
{
if(digitalRead(smoke)==LOW)
if(digitalRead(gas)==HIGH)
if(digitalRead(fire)==HIGH)
if(digitalRead(motion)==HIGH)
while(sms_count<1)
{
digitalWrite (smoke_led,HIGH);
```

```
digitalWrite (fire_led, LOW);
digitalWrite (gas_led, LOW);
digitalWrite (motion_led, HIGH);
digitalWrite (buzzer, HIGH);
sms_count=1;
}else{
sms_count=0;
}
//gas and fire detection section//
{
if(digitalRead(smoke)==HIGH)
if(digitalRead(gas)==LOW)
if(digitalRead(fire)==LOW)
if(digitalRead(motion)==LOW)
while(sms_count<1)
{
digitalWrite (smoke_led,LOW);
digitalWrite (fire_led, HIGH);
digitalWrite (gas_led, HIGH);
digitalWrite (motion_led, LOW);
digitalWrite (buzzer, HIGH);
sms_count=1;
}else{
sms_count=0;
}
//gas and motion detection section//
{
if(digitalRead(smoke)==LOW)
if(digitalRead(gas)==HIGH)
```

```
if(digitalRead(fire)==LOW)
if(digitalRead(motion)==HIGH)
while(sms_count<1)
{
digitalWrite (smoke_led,LOW);
digitalWrite (fire_led, LOW);
digitalWrite (gas_led, HIGH);
digitalWrite (motion_led, HIGH);
digitalWrite (buzzer, HIGH);
sms_count=1;
}else{
sms_count=0;
}
//fire and motion detection section//
{
if(digitalRead(smoke)==HIGH)
if(digitalRead(gas)==HIGH)
if(digitalRead(fire)==LOW)
if(digitalRead(motion)==HIGH)
while(sms_count<1)
{
digitalWrite (smoke_led,LOW);
digitalWrite (fire_led, HIGH);
digitalWrite (gas_led, LOW);
digitalWrite (motion_led, HIGH);
digitalWrite (buzzer, HIGH);
sms_count=1;
}else{
sms_count=0;
}
}
```

❖ **MAL-FUNCTIONING OF THE SENSORS**

The sensors are meant to sense signals when a gas, fire, smoke or motion is detected. It was discovered, however, that the sensors did not detect any of it due to wrong connections. After troubleshooting, it was discovered to be as a result of bugs in the control program. The bug was corrected in the program and it worked normal.

6.4 RESULT

The figure below shows the result (alert) of the design.

❖ **For smoke detection**

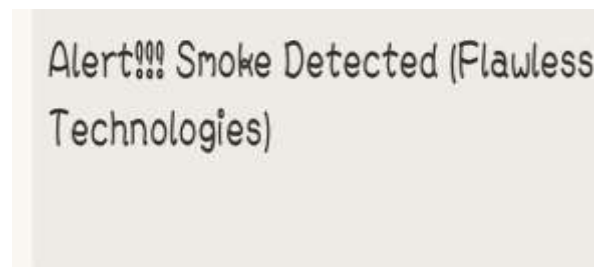

Fig 4.1: alert for smoke detection

❖ **For gas detection**

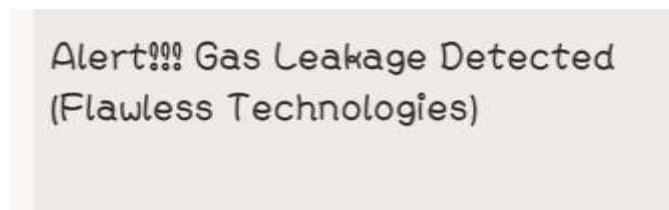

Fig 4.2: alert for Gas detection

❖ **For fire detection**

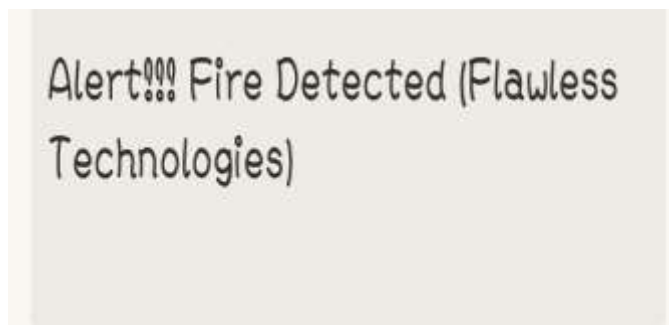

Fig 4.3: alert for fire detection

❖ For motion detection

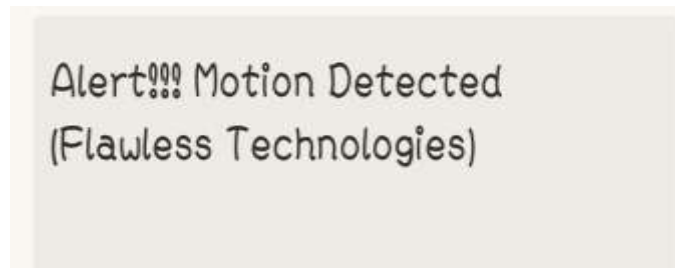

Fig 4.4: alert for motion detection

6.5 ANALYSIS AND DISCUSSION

At the end of the design, it is discovered that smart home users make it conceivable to gather extra data about the house hold. On account of smart home automation, this procedure happens in individuals' normal lives and ordinarily without their comprehension of the suggestions that this gathering may have on their protection and home security. The digital traces that the users leave behind may also be combined and extended with more general personal data, such as, aggregated neighborhood statistics, to a personal profile making both home and user vulnerable to various intrusions. The utilization and abuse of data may accordingly influence the potential advantages of presenting brilliant home computerization frameworks

6.6 SUMMARY

Smart home automation is design to ensure safety and security to our home remotely. At the end of the design, the information received from the sender at the receiving end show that the design was in a good working condition.

6.7 CONCLUSION

Having come to an end of the construction of gas, smoke, fire and motion detectors with SMS alert, we can now say that we have acquired a great wealth of experience in the field of electronics. We now understand how a circuit is designed using data sheets for specification and calculations. Acquainted with the knowledge of electronic components and identifying them using a multitude of test for values, building a circuit, soldering and assembling a circuit.

6.8 RECOMMENDATION

Having constructed the Gas, smoke, fire and motion detectors with SMS alert which worked effectively, we hereby recommend that provision for security alarm system should be included in the electrical services design for every home, office, industry, shop, bank and every area where humans are to be restricted. The government should embark on enlightenment campaign on the importance and use of the burglar alarm system.

We suggest that this device be used in indoor/outdoor security, offices, stores etc.

This burglar alarm is thus very good in safeguarding valuables.

6.9 NEED FOR FURTHER IMPROVEMENT

The need for further improvement is necessary so as to enable the system to operate in a wider range. For other improvement, other sensors can be included such as metal detection, weather detection etc.

REFERENCE

- [1] Abdul Razaque, Peter Oddo , Fathi H. Amsaad , Mohit Sangavikar, Sushil Manchikatla, (2016). Power Reduction for Smart Homes in an Internet of Things Framework, 2016 IEEE International Conference on Electro Information Technology (EIT). 10.1109/EIT.2016.7535225
- [2] Andrea C, Alessandra Papetti, Margherita Peruzzini, Michele Germani (2015). A smart home information management model for device interoperability simulation, a Department of Industrial Engineering and Mathematical Sciences, Università Politecnica delle Marche, Via Brecce Bianche 12, Ancona 60131, Italy.
- [3] Andi Adriansyah, & Akhmad Wahyu Dani (2014). Design of Small Smart Home system based on Arduino, Department of Electrical Engineering, Faculty of Engineering, Universitas Mercu Buana Jl. Raya Meruya Selatan, Kembangan, Jakarta, 11650, Indonesia.
- [4] Ananthram Swami, S. Barbarossa & Gesualdo Scutari (2007). Achieving Consensus in Self-Organizing Wireless Sensor Networks: The Impact of Network Topology on Energy Consumption. DOI: 10.1109/ICASSP.2007.366367 · Source: IEEE Xplore Conference: Conference: Acoustics, Speech and Signal Processing, 2007. ICASSP 2007. IEEE International Conference on, Volume: 2
- [5] Bittermana N. & D. Shach-Pinslya (2015). Smart home – a challenge for architects and designers, Faculty of Architecture and Town Planning, Technion – Israel Institute of Technology, Haifa 32000, Israel.
- [6] Boban Davidović & Aleksandra Labus (2016). A smart home system based on sensor technology, Vaimo Norge AS, Oslo, Norway, Faculty of Organizational Sciences, University of Belgrade, Serbia
- [7] Costin Badica, Marius Brezovan & Amelia Badica, (2016). An overview of smart home environments: Architectures, technologies and applications. University of Craiova Bvd. Decebal, 107, 200440 Craiova, Romania.
- [8] David J. Brooks (2011). Intruder alarm systems: Is the security industry installing and maintaining alarm systems in compliance to Australian Standard AS2201. Security Research Centre (SECAU), Edith Cowan University, 100 Joondalup Drive, Joondalup, WA 6027, Australia.
- [9] Davor Bogdanović, Tea Kvolik, & Goran Horvat (2016). Modular Smart House System Based on a Wireless Sensor Network, Josip Juraj Strossmayer University of Osijek, Faculty of Electrical Engineering, Department of Communications KnezaTrpimira 2b, Osijek, Croatia.
- [10] Dr. S.Vijayarani¹ and Ms. & Maria Sylviaa.S (2015). Intrusion Detection System – A Study. Department of Computer Science, Bharathiar University, Coimbatore
- [11] Freddy K Santoso & Nicholas C H Vun, (2015). Securing IoT for smart home system. Conference: Conference: 2015 IEEE International Symposium on Consumer Electronics (ISCE). DOI: 10.1109/ISCE.2015.7177843
- [12] Hari Priya. D, & Lalith Babu, (2014). Gas leakage system. ECE, Saveetha School of Engineering, International Journal of Scientific and Research Publications, Volume 4, Issue 9, September 2014.
- [13] Hussam Elbehiery, (2012). Developed Intelligent Fire alarm system, Department of Computer Science, Faculty of Information Technology, Misr University for Science and Technology (MUST), Cairo, Egypt.
- [14] Huan Hui Yan, & Yusnita Rahayu, (2014). Design and Development of Gas Leakage Monitoring System using Arduino and ZigBee. Faculty of Electrical and Electronics Engineering Universiti Malaysia Pahang Kampus Pekan, 26600 Pekan, Pahang Darul Makmur.
- [15] Jan Dolezal (2008). Design of Smart home Multi-layer Control system, Czech Technical University In Prague Faculty of Electrical Engineering Department of Control Engineering.

- [16] Juan Carlos Augusto, Juan Carlos (2006). *Augusto Designing Smart Homes: The Role of Artificial Intelligence. Designing Smart Homes: The Role of Artificial Intelligence*, ISBN:354035994X
- [17] Kausik Sen, Jeet Sarkar, Sutapa Saha, Anukrishna Roy, Dipsetu Dey, Sumit Baitalik, Chandra Sekhar Nandi (2015). *Automated Fire Detection and Controlling System*, Faculty of Applied Electronics and Instrumentation Engineering Department, University Institute Of Technology, Burdwan University, W.B. India.
- [18] Liu, Z.G.; Makar, J.M. & Kim, A.K (2001). *Development of fire detection systems in the intelligent building*, Institute for Research in Construction National Research Council of Canada, Ottawa, Canada.
- [19] Lili Liua, Eleni Strouliab, Ioanis Nikolaidisc, Antonio Miguel-Cruza,d, Adriana Rios Rincona (2016). *Smart homes and home health monitoring technologies for older adults: A systematic review*. Department of Occupational Therapy, Faculty of Rehabilitation Medicine, University of Alberta, 2-64 Corbett Hall, Edmonton, T6G 2G4 AB, Canada.
- [20] Martin Lärka, (2015). *Smart homes with smartphones* Umeå University Department of Applied Physics and Electronics.
- [21] Manish P. Deshmukh & Dr. P.M. Patil (2013). *Rotation and Translation Invariant System for Criminal Identification by Palm Print Evidence*. *International Journal of Application or Innovation in Engineering and Management*.
- [22] Md Iftekharul Mobin, Md Abid-Ar-Rafi, Md Neamul Islam, and Md Rifat Hasan (2016). *An Intelligent Fire Detection and Mitigation System Safe from Fire (SFF)*. Department of Computer Science and Engineering University of Liberal Arts Bangladesh, 4/A anmondi, Dhaka-1209.
- [23] Muhammad Asadullah, , Khalil Ullah (2018), *Smart Home Automation System Using Bluetooth Technology*. Department of Electrical Engineering National University of Computer and Emerging Sciences Peshawar, Pakistan.
- [24] Muhammad Asadullah, Ahsan Raza (2017), *An Overview of Home Automation Systems*, Department of Electrical Engineering National University of Computer and Emerging Sciences Peshawar, Pakistan.
- [25] Muhammad Yahya Bin Hamdzani (2013). *Gas Leakage And Fire Alert Warning System Via Gsm*, Faculty of Electronics and Computers Engineering Universiti Teknikal Malaysia Melaka.
- [26] Nimsiri Abhayasinghe, Iain Murray (2014). *Human activity recognition using thigh angle derived from single thigh mounted IMU data*. DOI:10.1109/IPIN.2014.7275474
- [27] Omorogiuwa Eseosa, Elechi Promise (2014). *GSM Based Intelligent Home Security System for Intrusion Detection*. *International Journal of Engineering and Technology Volume 4 No. 10, October, 2014*
- [28] Othman O. Khalifa, A. Albagul, Sheroz Khan, Mohd Rafiqul Islam, Noruzaihan Mod Usman (2008) *Wireless Smoke Detection System*, *Electrical and Computer engineering, Kulliyah of Engineering, International Islamic University Malaysia*,
- [29] Raqibull Hasan, Mohammad Monirujjaman Khan, Asaduzzaman Ashek, Israt Jahan Rumpa (2015). *Microcontroller Based Home Security System with GSM Technology*, Department of Electrical and Electronic Engineering, Primeasia University, Dhaka, Bangladesh. *Open Journal of Safety Science and Technology*, 2015, 5, 55-62.
- [30] Roslin John Robles¹ and Tai-hoon Kim (2010) *Applications, Systems and Methods in Smart Home Technology: A Review* *1School of Multimedia, Hannam University, Daejeon, Korea*
- [31] Satish Palaniappan, Naveen Hariharan, Naren T Kesh, Vidhyalakshimi S, Angel Deborah S, (2015), *CSE, SSN College of Engineering, Anna University, Chennai, India International Journal of Computer Applications (0975 – 8887)*.
- [32] Sadeque Reza Khan, Ahmed Al Mansur, Alvir Kabir, Shahid Jaman, Nahian Chowdhury (2012). *Design and Implementation of Low Cost Home Security System using GSM Network*, *International Journal of Scientific & Engineering Research*.

- [33] Shiu Kumar (2014). Ubiquitous smart home system using Android application Department of Information Electronics Engineering, Mokpo National University, 534-729, Mokpo, South Korea.
- [34] Sheikh Azid, & Sushil Kumar, (2011). Analysis and Performance of a Low Cost SMS Based Home Security System. School of Engineering and Physics The University of the South Pacific.
- [35] Timothy Malche, Priti Maheshwary, (2017). Internet of Things (IoT) for building Smart Home System, AISECT University, Bhopal, MP, India.
- [36] Venkatesan N.E., Tarun Agarwal, V.Lalitha, P.Vijay Kumar (2010). Distributed intrusion detection in the presence of correlated sensor readings: Signal-space and communication-complexity view-point. <https://doi.org/10.1016/j.adhoc.2010.07.015>
- [37] Vincent Ricquebourg, David Menga, David Durand, Bruno Marhic, Laurent Delahoche, Christophe (2014). The Smart Home Concept : our immediate future, Avenue des Facultés le Bailly 80000 Amiens France.
- [38] Vaishnavi S. Gunge, Pratibha S. Yalagi (2016). Smart Home Automation: A Literature Review. Walchand Institute of Technology Solapur. International Journal of Computer Applications (0975 – 8887).
- [39] Wickramasinghe M. G.. D. D, N. Abhayasinghe (2014). LP Gas Leakage Alarm, Department of Electronic and Computer Engineering, Sri Lanka Institute of Information Technology (SLIIT), Malabe, Sri Lanka.
- [40] Xiang Gao, Li Zhao (2010). Research and Design of Smart Home System Based On Zigbee Technology. Automation College Nanjing University of Posts and Telecommunications, NJUPT Nanjing, China.