

Smart Tracking System for Healthcare Monitoring Using GSM/GPS

Nazia Sulthana¹, Diwakar Tiwary²

¹M.Tech Scholar, ECE Department, Sree Dattha Institute of Engg and Sc, Ibrahimpatnam, Telangana State, India

²Assistant Professor, ECE Department, Sree Dattha Institute of Engg and Sc, Ibrahimpatnam, Telangana State,

Abstract - The designing and undertaking of subtle, consistent observing in the house or doctor's facility with the obtained patient's well being checkup. The plan incorporate temperature transducers which notice the surrounding temperature of individual, beat checking transducer peruse the beat rate. These sensors take parameters and send to a u-controller; the microcontroller gathers the parameters and orchestrates in particular organization for the qualities if display inside advances the parameters to the client portable in the sms arranges utilizing G.S.M Module. The sensor esteems are gathering by clients versatile which enable the gathered parameters which can lead to the wellbeing agent. G.P.S device in tracking situations.

Key Words: Transducer, Sensor, Microcontroller, G.S.M Module, G.P.S device.

1. INTRODUCTION

In investigation of overall information worldwide weight of hypertension that is heart illnesses, the examination demonstrates that many individuals are getting affected. As opposite to the hypertension ailments, the high blood is a factor and ascribes to cause numerous different issues, for example, stroke aneurysms, ischemic. The fatal issue of heart disappointment, the Hypertension is practically expanded by factor a few overlay, and represents around 25% of all heart disappointment cases. Also, the hypertension in 90% of cases went before or propelled the heart disappointment adjustably for elderly. Hyper - tension was positioned thirteenth worldwide reasons. Measurements of quantities responsible for sickness and were not accessible for awful state of numerous nations center East locale, so this task may urge applicable establishments to gather such insights.

In a time of sluggishness and lack in daily workout, fat, sugar, meats, smoking, corpulence, and the absence of eating leafy foods. Below the dimness of troublesome monetary circumstance, physical weakness, stretch and to having dignified life the circulatory strain illness has been the renowned in century cause poor dietary patterns. These neurological conditions are head of this sort of ailment, in numerous nations. The medicinal mediation is degrade the impacts however Smart and Innovative arrangements have to be received to build the responsive activities quality in both time and level. Here we advise framework engineering for brilliant social insurance with G.S.M and G.P.S advancements.

2. RELATED WORK

In perspective to this it was certified and sufficiency of this endeavors and engages correspondence between the person and his master. Utilizing the available organizations of G.S.M and G.P.S advances to construct a keen is sent in a flash to the essential individual contains: the name, heartbeat rate, disease/illness, the zone and the relating UTC time-stamp. Plotting of Electro-cardiogram (E.C.G) patterns by sending the scrutinizing to a specific processor.

2.1 Embedded Technology: A correct significance of embedded structures is troublesome. Basically communicated, all figuring systems of valuable PC (with screen, reassurance, etc.) are embedded structures.

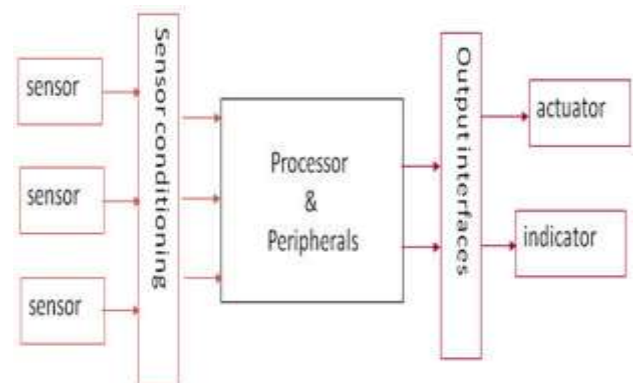

Fig 1 Block diagram of embedded system

Few embedded systems in existence

- ❖ Avionics, inertial heading systems, airplane control hardware/ programming composed structures in machine and rockets.
- ❖ Mobile/Cellular central switching.
- ❖ Engine controllers and non-solidifying ceasing gadget controllers for vehicles.
- ❖ Home robot things indoor controllers, air circulation/cooling frameworks, sprinklers, and security watching systems.
- ❖ Handheld calculators.
- ❖ Handheld/Portable PC control.

2.2 Characteristics: Introduced structures area unit relied on to try and do some explicit task needed to be totally necessary laptop for various endeavours. Some equally have execution necessities should be famed, for reason, as a relevant example, prosperity and usefulness. Others have low execution essentials, empowering the structure hardware cost reduction. This is not given by and large an alternate square - all the time physically worked in to the device that is controlling. The item created for introduced structures is routinely called firmware, and is secured in perused just memory or Flash memory chips more than a circle drive. It frequently continues running with compelled hardware resources: almost no comfort, screen, and little memory.

2.3 CPU platform: uProcessors are often of 2 clear classes: chip (μ P) and littler scale controllers (μ C). Littler scale controllers have worked in peripherals on-chip, decreasing structure's size. The famous variety of CPU structures used as an emb. plans.

- ❖ **Software tools:** There are a couple of unmistakable sorts of programming designing in like way use.
- ❖ **Simple Control Loop:** In this layout the item merely with a circle. The circle calls subroutines, it's managing somewhat gear or programming.
- ❖ **Interrupt based system:** Some systems are dominantly impeded controlled. This implies endeavours applied by the system are enacted by totally different events. Associate in Nursing impede may well be used, by checking in an exceedingly predefined repeat, or by an interface controller obtaining a computer memory unit. The low torpidity is needed by the system properties handlers of short and clear for this reason.

These systems run a necessary task in a necessary circle in same, but this endeavour is not particularly fragile to surprising deferrals interrupt idleness to a base. One or two of times longer assignments square measure intercalary to a line structure within an interfere handler to be started with a commonplace circle later. This passes on structure nearly a multitasking phase with separate methodology.

2.4 Debugging: Implanted Debugging might be performed at distinctive levels in offices accessible, going from get together or source-level troubleshooting with a built-in emulator or available debugger as the appearance of inserted frameworks develops, larger amount apparatuses and working frameworks are relocating into hardware where it available phones, individual advanced collaborators purchaser PCs frequently require critical programming that is obtained or given by a man to other hardware.

2.5 Reliability: Embedded frameworks required to run persistently for a considerable amount without mistakes and

sometimes recoup by them if a blunder happens. Hence, the product is typically created and tried more deliberately than that for PCs, and problematic mechanical moving parts, for example, plate drives, switches or catches are evaded.

Recuperation from blunders might be accomplished with systems, for example, a guard dog clock that resets the PC unless the product occasionally advises the guard dog. Particular unwavering quality issues may include:

- ❖ The framework can't securely repair, or it is excessively hard in repair. Arrangements may include subsystems with excess extras that can be changed over to, or programming "limp modes" that give halfway capacity. Illustrations incorporate space frameworks, undersea links, navigational signals, drill gap frameworks, and vehicles.
- ❖ The framework must be continued running for wellbeing reasons. Frequently reinforcements are chosen by an administrator. Cases incorporate air ship route, reactor control frameworks, wellbeing basic compound plant controls, prepare signals, motors on single-motor flying machine.
- ❖ The framework will lose cash when Telephone switches, Processing Plant controls, extension and lift controls, stores exchange and market making, mechanized deals.

High vs. Low Volume: For high volume structures helpful music players or phones, constraining cost is by and large the arrangement thought. Planners generally select hardware in adequately "extraordinary" for limitable execution. For low volume or model embedded structures, comprehensively valuable PCs are balanced by obliging the activities or by supplanting the working system progressing working state.

Interrupt controlled system: The dominantly hindering controllable system coded embedded system. This implies errands perform by the framework are different in various situations. A hinder could be produced by a clock in a predefined recurrence, or by a serial port controller getting a byte. These structures frameworks are utilized if occasion handlers require least idleness and handlers are short and straightforward.

Generally these structures frameworks run a straight forward undertaking in circle likewise, yet this errand is not extremely delicate to startling deferrals. The undertakings performed with handlers kept the intruder on idleness to a base. These assignments no further added to a line structure with handler to be prepared in the fundamental circle later. This strategy conveys the framework near a portion with discrete procedures.

III. PROPOSED METHOD

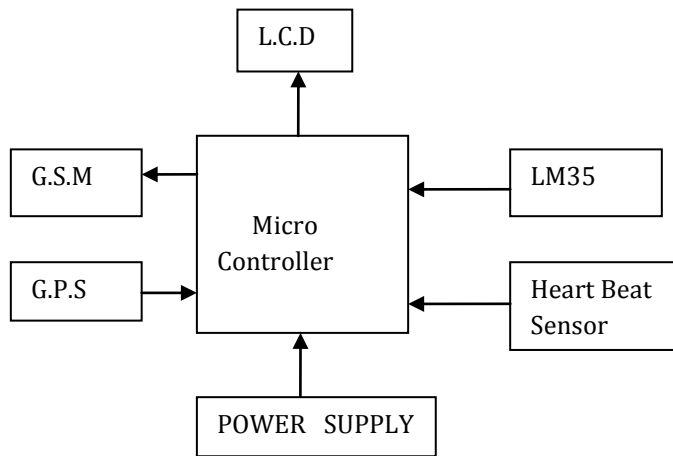

Fig 2 Block Diagram of proposed model

IV SCHEMATIC DIAGRAM

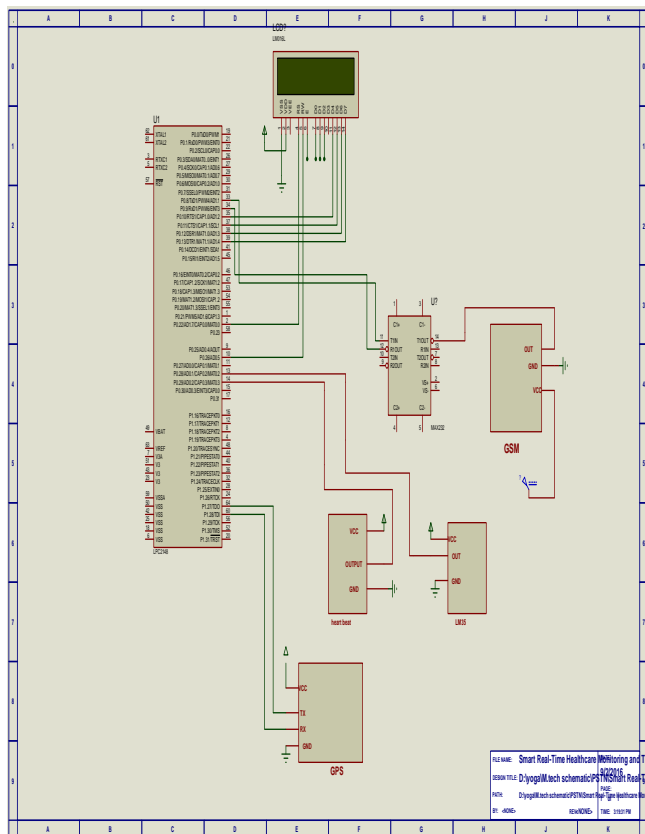

Fig 3 Schematic diagram of proposed model

4.1 Cooperative multitasking: There is no preemptive system is on a very basic level the same as the fundamental control hover plot, except for that the circle is concealed in an API. Build of prototype portrays a movement of assignments, and each endeavor gets its own condition to "run" in. By then, when an endeavor is apparatus, it calls a sit

without moving routine (called "stop", "hold up", "yield", etcetera.). This focuses and shortcomings are in general the same as the control hover, except for that including new writing computer programs is less requesting, by simply composed work another process or other addition to the line interpreter.

4.2 Preemptive multitasking: A code exchanges between errands clock. This is the level at which the systems here are considered to have a "working structure", and exhibits each one complexities of managing different assignments running evidently meanwhile. Any program task coding will hurt the data of another endeavor; they precisely secluded. Accessing the shared information synchronization system and the message lines or semaphores or a non-blocking synchronization plan. These complexities are customary for relationship to consistent working structure, empowering the application engineers considering contraption handiness in the simple system organizations.

V ARM PROCESSORS FOR EMBEDDED DESIGNS

5.1 The Complex Instruction Set Computer

All present uC chips depend on C.I.S.C architecture method. The commonplace C.I.S.C microcontroller has well much guidelines intense and exceptionally particular for particular control assignments. It is very basic for the guidelines to all carry on in an unexpected way. Few systems just certain address spaces or registers can just perceive certain tending to modes. The advantageous C.I.S.C design is that considerable guidelines are full scale like, enabling the developer to utilize one direction set up of numerous difficult directions. Likewise, numerous nonstandard state programming develops are upheld. To separate the unpredictability of guidelines, a miniaturized scale sequencer inside the C.P.U is utilized.

5.2 Cache

As said some time as of late relationship between a brisk processor and by and large direct memory could transform into a bottleneck. This issue is had a tendency by introducing stores. A save is a more common, speedier memory store data with main and useful memory regions. Right when the processor wishes to scrutinize or form a territory on a basic level memory, it at first checks whether that memory zone is in the save. The memory region is within the save then we are saying that successful store went on else we need to mention a save miss. A save hit the processor rapidly scrutinizes or makes the info within the store line. A save miss, most stores dole out another section, which includes the data from the memory essentially missed. Exactly when holding of data, it should provide runtime process in guideline memory moreover.

ARM LPC2148

The LPC2148 microcontroller relies upon a 32/16 bit ARM7TDMI-S CPU with progressing duplicating and embedded take after reinforce, that joins the microcontroller with introduced quick burst memory stretching out from 32 kb to 512 kb.

In view of unassuming size and low power usage, LPC21418 is ideal for applications where downsizing is a key essential; get the chance to control and reason for offer.

Program Counter (PC)

During ARM State processing:

- ❖ All directions are 32-bit wide.
- ❖ All directions must be adjusted as word.
- ❖ Therefore, the PC esteem is put away in bits 31:2 with bits 1:0 vague (as direction can't be half expression of byte adjusted).

HD162A L.C.D a display

16*2 Alphanumeric Dot Matrix Modules

As recently the Liquid Crystal Display is finding broad utilize replacement light-emitting diode (seven-fragment Light Emitting Diodes or alternative multi portion Light Emitting Diodes):

- ✓ The declining costs of L.C.D s.
- ✓ The capacity to show numbers, characters and designs.
- ✓ This is in contract to L.E.D which is constrained to numbers characters.
- ✓ Ease of programming for characters and designs.

5.3 SERIAL COMMUNICATION Port

PCs will move information in 2 ways: the parallel technique and serial technique. The parallel information trades. Instances of parallel information trade area unit printers and arduous plates; every usage joins with several wire strips. To trade to a device discovered many meters away, the serial method is compulsory. Serial correspondence to 8051 is the subject of this part. The 8051 has serial correspondence limit consolidated with it impacting possible brisk data to trade using less wires.

If data is to be traded respect to telephone line, it must be changed over from 1s to sound tones, which are sinusoidal-framed signs. A periphery contraption which stays for "modulator/demodulator", plays out this change. Serial data correspondence uses two techniques, unique and synchronous.

In data transmission it is a duplex transmission. This is rather than simplex transmissions, in which the PC just sends data. Duplex transmissions can be half system or full

system duplex, dependent upon paying little respect to whether the data trade can be synchronous. If data is transmitted one course double, it is suggested as half duplex. If the data can go the two courses meanwhile, it is full duplex. Clearly, full duplex requires two wire courses for the data lines, one for transmission and one for social occasion, with a particular true objective in the data trading and security.

5.4 MAX 232 Serial Line Drivers

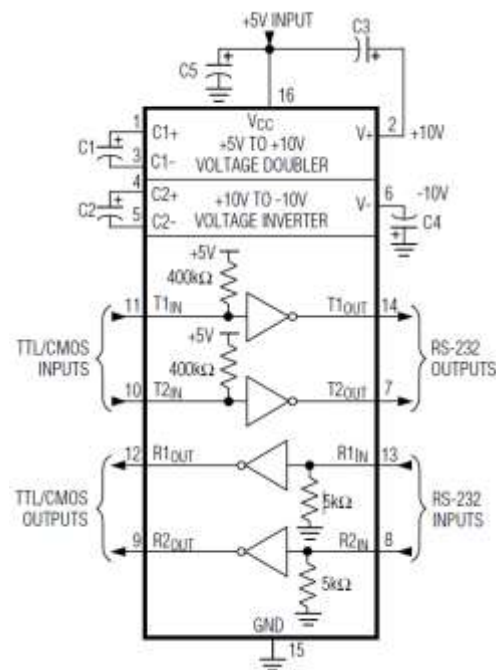

Fig 4 MAX 232 Operating Circuit

The Pin 11, 10 frame the double contributions with TTL rationale while 14, 7 shape the yields for RS 232 rationale, and the 12, 9, 13, 8 frame the different part is data device/sources and yields as appeared in figure. The sources of info and yields of drivers and beneficiaries are appeared.

Asynch. Serial Communication with Data Framing

The data alluring is difficult to understand the data unless the sender and authority yield to a course of action of standards, a tradition, on how the data is squeezed, what number of bits constitutes a character, and when the data begins and wraps up.

Bits for Start Bit or Stop Bit in Frame

Non-simultaneous serial data correspondence is by and large used for character-orchestrated transmissions, while piece arranged data trades use the synchronous system. In the unique system, each character is set among start Bits and stop Bits. This is called limiting. In the data surrounding for

strange exchanges, the data, the start bit is always one piece, however the stop bit can be perhaps a few bits. The start bit is reliably a 0 (low) and the stop bit (s) is 1 (high).

5.5 G.S.M MODULE

This is a Quad band phone, which tackles a repeat of 900/1800 and be used to get to the services and for oral correspondence (gave that it is related with an intensifier and a little rambunctious speaker) and for S.M.S. Remotely, little doubt an interesting package (0.94 inches' x zero.94 inches' x zero) with L-shaped contacts on four sides in order that they will be sure each as slightly of discernment and at the bottom. Inside, the module is supervised by associate AMR926EJ-S processor, that controls phone correspondence, knowledge correspondence (through a joined the correspondence with the cellular phone itself. The processor is same as responsible for a S.I.M card (3 or 1.8 V) which joined to the outside mass of module. In addition, the G.S.M900 device consolidates an easy interface, associate degree A/D convertor, a R.T.C, a S.P.I transport, an I²C, and a P.W.M module. The radio section is G.S.M organize 2/2+ great and is either class 4 (2 W) at 850/900 MHz or class (1 W) at 1800/1900MHz. G.S.M electronic equipment is either an overseas correspondence module or an electronic equipment convenience, which have influence a computer processor to impart over a system. G.S.M electronic equipment needs a S.I.M card for operation and works over a system extend signed by the supervisor. It is often related the computer through a serial device or U.S.B or Bluetooth association.

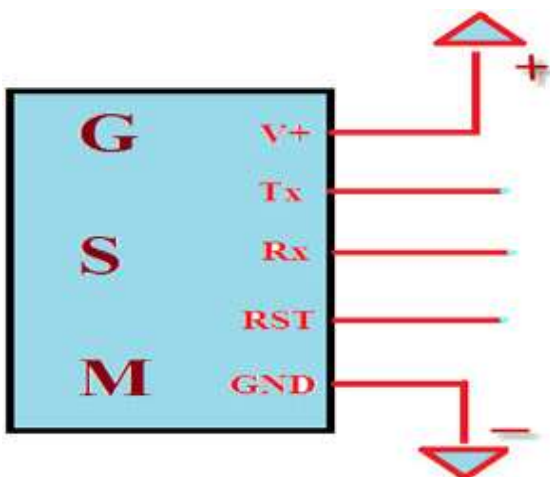

Fig 5 G.S.M Modem

Step1: Configuring the G.S.M Modem

The setting of "AT" commands with instant messages. These AT charges customized in the microcontroller guarantees sending or accepting a S.M.S from the G.S.M modem, without which the instant messaging facility.

Step2: Testing the G.S.M Modem

The G.S.M modem comprises of two L.E.Ds for example, green or red L.E.Ds for the sign of system association. The off chance the older system, at that point the red L.E.D gleams, and if a system is accessible then the green L.E.D shines with the goal that one can watch the G.S.M modem's working.

Associate a power supply to a S.I.M contained G.S.M modem and wait till it is enlisted in the G.S.M arrange. At that point a S.M.S to the G.S.M modem for testing; in the event that it gets the message from the versatile – it is working fine, or else – it is flawed.

Step3: Interfacing the G.S.M Modem with the ucontroller

The modem of G.S.M can't be related with a u-controller in light on way that the microcontroller works with 5v DC control supply, however the G.S.M modem with a12V DC.

The G.S.M is interfacing with microcontroller through a M.A.X-232 gadget with the assistance of R.S-232 link for serial information correspondence where in the M.A.X-232 gadget is utilized to change the T.T.L/C.O.M rationale levels to R.S-232 rationale levels amid serial correspondence of microcontroller to the G.S.M modem.

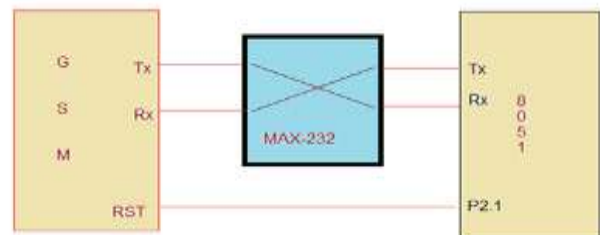

Fig 6 G.S.M and 8051 communication setting

5.6 G.P.S MODEM

A G.P.S recipients utilize a star grouping of available satellite. The ground available stations to register state and timing anyplace on earth.

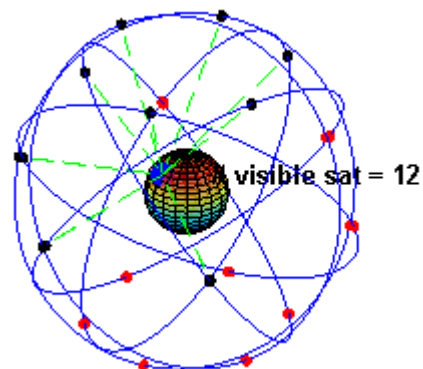

Fig 7 G.P.S receiver calculation of its state/timings

The packet data sent common sense from each satellite contains different scraps of information that empowers your G.P.S gatherer to definitely figure its position and time. A basic piece of apparatus on each G.P.S satellite is a to an extraordinary degree correct atomic clock. The packages are sent sensible nearby orbital position and section times at different concentrations in the sky. From this information, the recipient now, knows the G.P.S partition to each satellite in observe. If the G.P.S beneficiary's receiving wire can capture min. 4 satellites, it can unequivocally find out its position and time.

Readings from a G.P.S data

- 1) Available systems of G.P.S supported comm. which influences them to communicate with a u-controller or PC.
- 2) **Connecting a G.P.S to a u-controller**

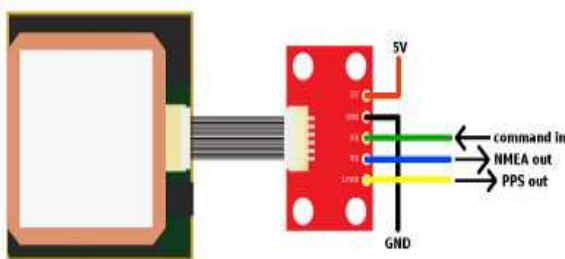

Fig 8 EM406 G.P.S with EM406 Breakout

It is regular for the ucontroller to analyse the N.M.E.A info. Parsing is simply discharge the lumps from the N.M.E.A pack sentence that the microcontroller will accomplish one thing valuable with the knowledge.

5.7 SENSORS

Choosing Sensor

Variables to consider while picking a sensor:

- ❖ **Accuracy:** The measurable change about the correct perusing.
- ❖ **Calibration:** Required for most measuring frameworks since their readings will float after some time.
- ❖ **Cost Environmental:** Sensors regularly have temperature or potentially dampness limits.
- ❖ **Range:** Limits of estimation or the sensor.
- ❖ **Repeatability:** The change in a sensor's perusing when a solitary condition is over and again measured.
- ❖ **Resolution:** The littlest augmentation of sensor can distinguish.

Temperature transducer/Sensor (LM35): The LM35 course of action is precision facilitated circuit temperature sensors, whose yield voltage is straightly versus the scale of degree Centigrade. The LM35 in this manner has leverage over straight temperature sensors balanced in ° Kelvin, as the customer isn't required to subtract a considerable consistent voltage from its respect get supportive. The LM35 does not require any outside arrangement or trimming normal exactness's of $\pm 1/4^{\circ}\text{C}$ at room temperature and $\pm 3/4^{\circ}\text{C}$, over a full -55 to $+150^{\circ}\text{C}$ temperature broaden.

Features:

1. Calibrated specifically in Celsius Centigrade scale.
2. Linear output voltage of +/- 10 milli Volt.
3. $1/2$ degree precision ensure capable.
4. Rated for full -55° to $+150^{\circ}\text{C}$ territory.
5. Suitable for remote applications.
6. Low cost because of wafer-level trimming.
7. Operates from 4 to 30 volts.
8. $60 \mu\text{A}$ current deplete.
9. Low self-warming, 0.08°C in still air.
10. Nonlinearity just $\pm 1/4^{\circ}\text{C}$ common.
11. Low impedance yield, 0.1W for 1 mA current.

HEART BEAT SENSOR: Heart beat sensor is planned propelled yield of warmth beat when a finger is put on it. At the purpose of beat finder is functioning, the beat junction rectifier flashes collectively with each pulse.

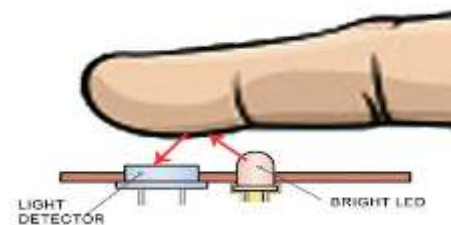

Fig 9 Heart beat finder sensor

This electronic yield is connected with microcontroller Beats every Minute Beats. It tackles the administer of sunshine amendment by blood travel through finger at each pulse. A clear heartbeat signal transducer is created by infrared L.E.D and a highly reliable phototransistor. It works since skin goes about as a savvy plane or surface side for infrared light. The IR reflectivity of skin depends in respect to thickness of blood in it. Blood thickness rises high and falls down with the organizing active heart. So in this way transmitted to the photo transistor path rises high and falls down with every pulse.

Applications

1. Digital Heart Rate Screen.
2. Patient Monitoring System.

3. Control of mechanical autonomy and applications etcetera.

Working Principle: The sensor comprises of a red L.E.D bright one and light finder. The L.E.D should be super splendid as the most extreme light should pass spread in finger and distinguished by identifier. Presently, when the heart pump the blood in veins, the finger turns out to be marginally mistier thus less light achieved the finder. With increasing beats, the identifier flag fluctuates. This variety is changed over to electrical heartbeat. This flag is activated through a loud speaker which yields +5V rationale level flag. The yield flag is likewise demonstrated by a L.E.D which squints on every pulse and the given sensor flag yield diagram.

Underneath figure demonstrates real heart beat got by identifier (Yellow) and the trigger purpose of sensor (Red) after which the sensor yields advanced flag (Blue) at 5V level.

6. RESULT

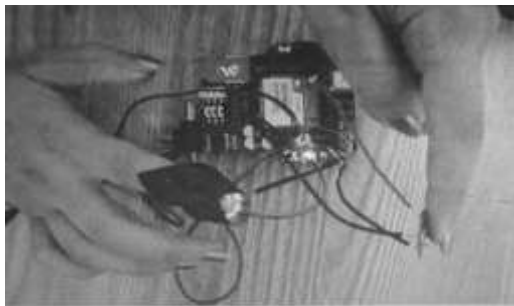

Fig 10 -Working of the proposed model

7. CONCLUSION AND FUTURE SCOPE: Point of Smart City ideas is in relation with better life to society and give imaginative and innovative arrangements in each eight mainstays of shrewd city. Social insurance field is one of most sensitive and imperative field to be produced an improved Smart frameworks intended to introduce economical therapeutic mediations at way time where the savvy framework straightforward and continuous criticism.

The framework outlined tested and paper granted success nature of wellbeing administrations and to diminish the aggregate cost in social insurance by evading that an individual granted by the great facilities who really wanted them.

It is a framework with quantify pulse rate and temperature of human and impart them in circumstances of uncommon practices to supervision medicinal elements utilizing G.S.M and also G.P.S and web advancements to convey quick activities to safeguard patients existence with probability later on to include and consider other indispensable components estimations as indicated by accessible sensor in the market accomplish the task giving a

dependable powerful application to ongoing wellbeing checking and following.

This venture of 2 dependent variables is; first its multi-uses and administrations by making some pharmaceutical on product numerous ailments and ailments like Alzheimer, mental and movement patients could be benefited from this framework; also, remote advances could be utilized to dodge wired associations which by one means may constrain versatility.

ACKNOWLEDGEMENT

The authors are thank full to the management of Sree Dattha Institute of Engineering and Science for providing the lab resources. They are also thank full to the central library resources i.e digital library, ebook and other books.

REFERENCES

- [1] Sarwant Singh, Smart Cities – A \$1.5 Trillion Market Opportunity, Accessed: (29/11/2015), available <http://www.forbes.com/sites/sarwantsingh/2014/06/19/smart-cities-a-1-5-trillion-market-opportunity/>
- [2] Mikhail St-Denis, LifeLine, Accessed:(29/11/2015), available <http://www.mikhailstdenis.com/projects/personal-Life-Line.html>
- [3] Eckerson, Wayne W. "Three tier client/server architectures: achieving scalability, performance, and efficiency in client/server applications." Open Information Systems 3.20 (1995): 46-50.
- [4] P. M. Kearney, M. Whelton, K. Reynolds, P. Muntner, P. K. Whelton and J. He, Global burden of hypertension: analysis of worldwide data, Elsevier Ltd, 15 January 2005.
- [5] A. V. Chobanian, The Seventh Report of the Joint National Committee on Prevention, Detection, Evaluation, and Treatment of High Blood Pressure, JAMA, the Journal of the American Medical Association, May 21, 2003.
- [6] W. Kannel and J. Cobb, Left ventricular hypertrophy and mortality results from the Framingham Study,1992.
- [7] World Health Organization, The Global Burden of Disease, 2008.
- [8] World Health Organization, Disease and injury country estimates,2009.
- [9] Behance, LifeLine on Behance, Accessed: (13/11/2015), available at <http://www.behance.net/Gallery/LifeLinea/321119>.

- [10] Angel, Lumo Run - Revolutionary Smart Running Shorts, Accessed: (13/11/2015), available at <http://www.lumobodytech.com/>.
- [11] Thepu, how mobile is making us healthier, Accessed: (13/11/2015), available at <http://thepu.sh/trends/take-two-wearables-and-call-me-in-themorning-how-mobile-is-making-us-healthier/>.
- [12] Arduino Uno, Arduino - ArduinoBoardUno, Accessed: (13/11/2015), available at <https://www.arduino.cc/en/Main/ArduinoBoardUno>.
- [13] Dfrobot, GPS/GPRS/GSM Module V2.0 (SKU:TEL0051) - Robot Wiki, Accessed: (13/11/2015), available <http://goo.gl/r5Dm6u>.
- [14] 4project, Pulse sensor, Accessed: (13/11/2015), available <https://www.4project.co.il/product/pulse-sensor>.
- [15] dash.co.il, LilyPad Temperature Sensor, Accessed: (13/11/2015), available <http://goo.gl/xnglsv>.

BIOGRAPHIES



Ms Nazia Sulthana is M.Tech Scholar in Embedded System from Sree Dattha Institute of Engg and Sc. She has completed her B.Tech from JJIIT Maheshwaram, Hyderabad, Telangana in 2015. She has presented paper in Mahaveer Engg College and her major project got certificate in BSNL, Gachibowli in 2015.



Mr Diwakar Tiwary is Assistant Professor and M.Tech Coordinator in Sree Dattha Institute of Engg and Sc. He is PhD Scholar from Himalayan University and UGC NET qualified in 2014. He is having 8 national and 12 international paper to his credit. His area of interest include low power vlsi design, Digital signal processing and Embedded system.