

RESPONSE SPECTRUM ANALYSIS OF ELEVATED WATER TANK

Aleemuddin Tirandaz¹, Shameena Khannavar², M.H.Kolhar³

Research Center, Civil Engineering Department, Secab. I.E.T, Vijayapur. Karnataka, India.

Abstract - Storage reservoirs and overhead tank are used to store water, liquid Petroleum, petroleum products and similar liquids. The force analysis of the reservoirs or tanks is about the same irrespective of the chemical Nature of the product. All tanks are designed as crack free structures to eliminate any leakage, This project gives in brief, the theory behind the Analysis of liquid Retaining structure (Intze water tank with rigid base and Circular water tank) using STAAD Pro V8i. This Report also includes computer subroutines to analyze.

Key Words: Intze Water Tank, Circular Water tank, Response Spectrum Analysis, Hydrostatic Pressure, Base Shear, Nodal Displacement,

(Size 10 & Bold) Key word1, Key word2, Key word3, etc (Minimum 5 to 8 key words)...

1. INTRODUCTION

Storage reservoirs and elevated water storing tank are utilized to collect water, crude oil, oil based products and comparative liquids. Water or crude oil holding slab and Walls could be strengthened with sufficient covering to support. Water as well as oil responds along concrete and in this manner, so there is no need of extra treatment to the surface. Industrial waste can likewise be gathered and handled into the tanks along with couple of exemptions. oil based good, for example, petroleum products, crude oil, industrial chemicals and so on are probably going to leak through the concrete walls, in this manner such tanks require extraordinary layers to avoid spillage, and should also be free from any cracks. Repository is a typical term connected to fluid stockpiling structure and Liquid stockpiling, basically there are two types of tanks: tanks below ground and the other is Elevated tank. Repositories underneath the ground i.e., underground type of tanks are regularly used to stock vast amounts of water while the other type of elevated sort are worked for coordinate dispersion by gravitational flow stream and they can be rested on RCC columns, steel, RCC framing, or stone work platform, length of columns normally changes from 7 m to 25 m, and usually are of smaller capacity, This investigation is to distinguish the conduct of over head water tanks under various seismic zones and displaying of tank utilizing supporting programming Staad Pro V8i SS5 and Indian Standard codes.

1.2 Objective

1. Make a study on the modeling and analysis of water tanks.
2. Understand the design procedure for liquid storing structures in accordance with the IS-codes.
3. Gain knowledge about the analysis viewpoint for economical and safe water tank design.
4. Study the behavior of base shear, nodal displacements for various seismic zones and various loading conditions.

2. LITERATURE REVIEW

Several literatures were given in connection to technical documents to now on Seismic investigation of overhead Tanks. Several problems and points are dealt with this analysis, -i.e., dynamic response of framed staging and hydrodynamic pressure, and so forth. Some of them are given underneath.

- **Issar Kapadia, Purav Patel, Nilesh Dholiya, Nikunj Patel (2017):** In their paper entitled "Analysis and Design of INTZE Type Overhead Water Tank under the Hydrostatic Pressure as Per IS: 3370 & IS: 456 -2000 by Using STAAD Pro Software". carried out the study with help of the STAAD Pro Software, We made the conclusion as pointed

There is an increase in moment when the, height of the structure increases. When using fix joint at the base its remarkable reduction in base settlement. This type tank is simplest form as compare to the circular tank. We have given the inclination to the staging of water tank because as respected inclination the tank performs better than that type of straight one.

- **Rajkumar, Shivaraj and Prof. Mangalgi (2017):** In their paper entitled "Response-Spectrum Study Of High-Rised Intze and Circular Water Tanks" The total base shear in full tank condition are more than those in empty tank condition and half-filled condition in both seismic zones II and seismic zone V for both Intze and circular type of tank. Hence design is governed by full tank condition, 8.Design of elevated water tank is very complex which involves lot of mathematical calculations and time consuming. Hence Staad pro gives all parameters which are useful in design of elevated water tank.

- Ankush N Asati, Dr. Mahendra S. Kadu (2014):** In their paper entitled “**Seismic Investigation of Reinforced Concrete Elevated Water Tank for Different Types of Staging-Patterns**” Radial arrangement with six staging levels is best suited for ten numbers of columns followed by cross and normal. Full tank condition shows critical response than empty tank conditions. But we can't neglect empty tank condition.
- Nitesh J Singh, Mohammad Ishtiaque:** In their paper entitled “**FOR DIFFERENT WIND SPEED AND SEISMIC ZONES AS PER INDIAN CODES, ANALYSIS AND COMPARISON OF INTZE TYPE OF WATER TANK**” As the breeze speed and earthquake zones increments in favor of a similar withstanding ability quality of steel and quantity of concrete and increases while wind speed rises, the strength of the wind speed on the stage continues to increase for several cases. In any case, with the increase in load and moments of foundation, the size of the Raft Foundation continues to increase. In any situation, as wind speed continues to change or increase, the wind moments are computed by hand and checked by the Staad Pro varies between 4 % and 5 %.

Table -1: Parameters of Elevated Intze Tank

Particulars	Values or Dimensions
The Thickness of Top Dome	100mm
Rise of Top Dome (h1)	1.667m
Size of Top Ring Beam	300mm x 300mm
Diameter of Cylindrical Wall	10m
Height of the Cylindrical wall	3.3m
Thickness of Cylindrical Wall	150mm
Size of Middle Ring Beam	1000mm x 600mm
Height of Conical Dome	1.875m
Average diameter of Conical dome	6.25m
Thickness of Conical Dome	400 mm
Rise of Bottom Dome	1.25 m
Radius of Bottom Dome	3.125 m
Thickness of Bottom Dome	250 mm
Size of Bottom Ring Girder	480 mm x 1000 mm
No. of Columns	8nos
No. of Bracing Levels	3m,6m,9m,12m
Distance between intermediate Braces	3m
Size of Bracing	500 mm x 500 mm
The Size of Columns	0.6 m radius

3. DISCRIPTION OF MODELS

In the present investigation eight numbers of overhead Intze and circular water tanks of ability 3 Lakh liters upheld on Reinforced Cement Concrete frame staging in seismic loads according to IS:1893: 2002 code Part II are considered, including four Intze-type models, and four circular-type models. The analysis of the response spectrum for elevated Intze and circular tank with full and empty state which lies in earthquake zone V and III are done utilizing the software Staad-Pro V8i SS5.

3.1 Elevated Intze tank.

The model considered here is Intze kind of overhead water tanks of capacity 3L liters which is supported in the assembly of RCC frames of 12 m and 6 columns with horizontal beams connected at every 3 meter height at four levels which is also known as bracing. The overhead storage tank is located in zone III and zone V, type of soil is medium. Fe-415 steel and M20 grade concrete is used is for this thesis. The models are analyzed by Response Spectrum Analysis method in Staad - Pro V8i SS5.

3.1.1 Basic Components Of Intze Tank

Basic components of an Intze tank includes the following:

1. Upper circular dome
2. upper ring beam
3. Side circular walls
4. Beam of the lower ring
5. bottom Conical dome
6. Bottom circular dome
7. Bottom round gurder
8. Supporting Rcc Columns
9. Horizontal beam bracing and footing

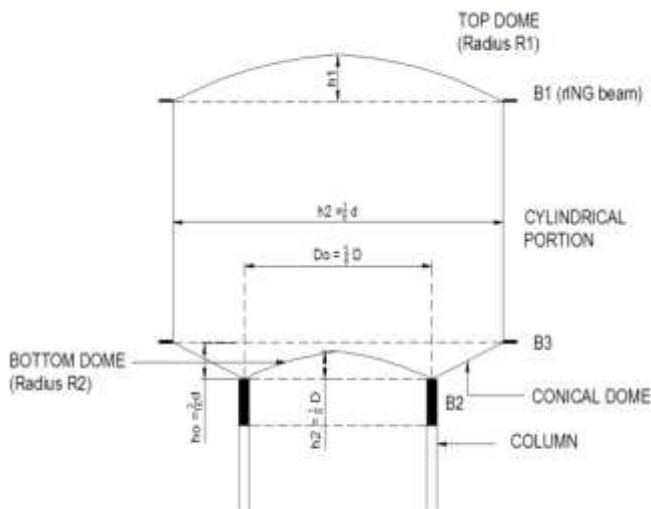

Fig 1: Components Of Intze Tank

3.2 Elevated Circular tank.

The second model considered here is circular kind of overhead tanks of capacity 4L liters resting on RCC staging of height 12 m and 6 no's of supporting column with parallel RCC bracings at 4 stages. The overhead tank is located in zones V and III on medium type soil. M₂₀ grade mix is used and Fe-415 reinforcement is used for this study. The models are analyzed using Response Spectrum Analysis in Staad Pro V8i SS5.

Table -2: Parameters of Elevated Circular Tank

ITEMS	DIMENSIONS
The Width of upper Dome	100 mm
ascend of upper Dome	1.467 m
Radius of upper Dome at base	8.8 m
dimension of upper Ring Beam	230 mm x 230 mm
Dia of Cylindrical Wall	8.8 m
Height of Cylindrical wall	5.68 m
width of Cylindrical Wall	200 mm
depth of Bottom floor Slab	480 mm
Bottom Ring Girder Size	480 mm x 1050 mm
Number. of Columns	8 nos.
Number of Stages in Bracing.	3, 6, 9, 12 meters
Difference between intermediate Braces	3 m
Size of Beam Bracing	500 mm x 500 mm
Size of supporting Column	0.6 m radius

3.2.1 Basic Components Of circular Tank

Basic components of an Circular tank includes the following:

1. Upper dome
2. Upper ring beam
3. Side Circular wall
4. Base Slab
5. Bottom ring girder beam
6. Supporting Rcc column
7. Horizontal beam bracing & Footing

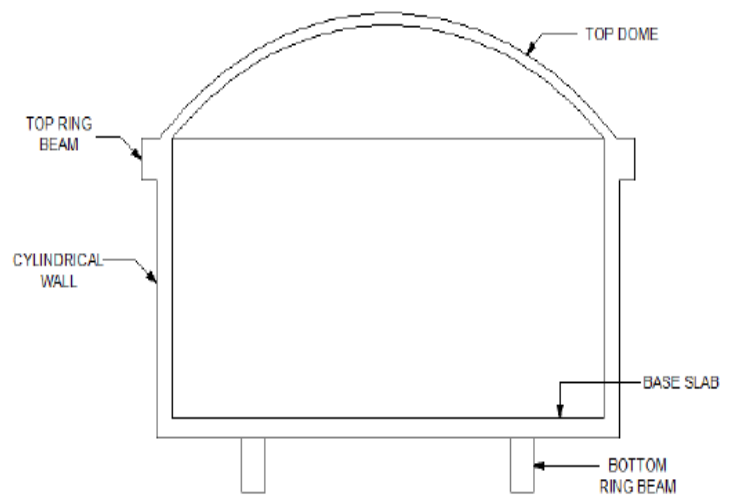

Fig 2: Components Of Circular Tank

4. RESULTS AND DISSCUSSION

The maximum reactions are acquired for different parameters of overhead storage tanks. These responses incorporate, nodal displacement, base shear constrain and time period. The seismic demands of the overhead tank are settled using the reaction range examination for the empty and full tank condition. The seismic zones III and V are taken for the examination

4.1 Base Shear in (KN)

Base shear values for Intze and circular model are acquired utilizing Response Spectrum Analysis from stad.pro.

Table -3: Base Shear Values For Zone III

BASE SHEAR VALUES FOR ZONE III		
WATER LEVELS IN TANK	CIRCULAR TANK	INTZE TANK
	IN KN	IN KN
EMPTY TANK	283.91	180.54
FULL TANK	537.41	1104.6

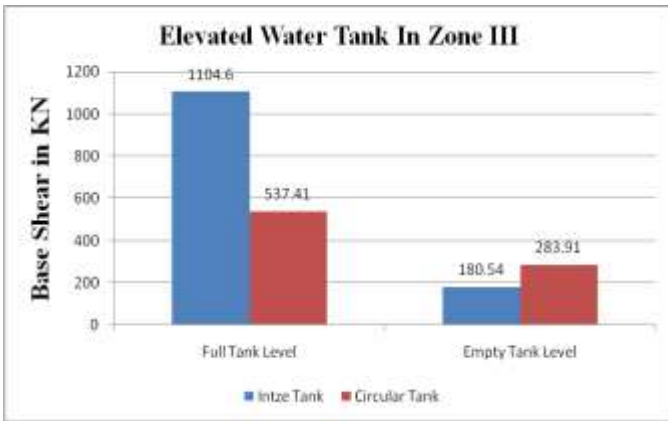

Chart 1: Base shear values for Intze tank and circular tank in zone III

Table -4: Base Shear Values For Zone III

BASE SHEAR VALUES FOR ZONE V		
WATER LEVELS IN TANK	CIRCULAR TANK	INTZE TANK
	IN KN	IN KN
EMPTY TANK	638.81	405.05
FULL TANK	2677.80	2482.82

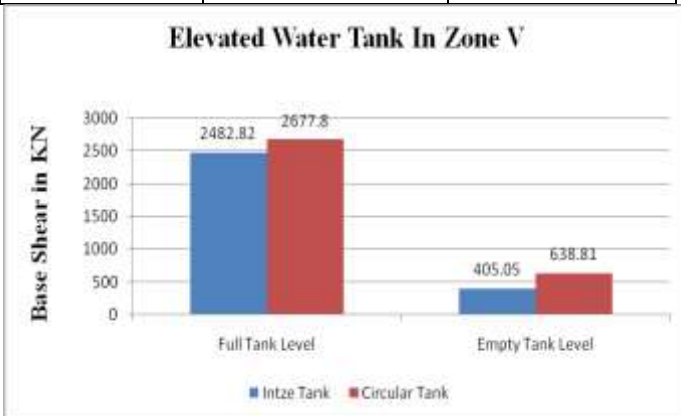

Chart 2: Base shear values for Intze tank and circular tank in zone V

Discussion on Base Shear values of the models.

1. Base shear of full water tank and empty water tank are increased with seismic zone II-V because of zone factor, response reduction factor etc. while considering seismic analysis.
2. Base shear in full condition tank is slightly higher than empty tank due to absence of water or hydro static pressure.

4.2 Nodal Displacement.

Displacement values for circular and Intze models are obtained from Response spectrum analysis from the staad.pro software under seismic zones III and V for different levels of water.

Table 5: Displacements in Intze Tank in zone III

Seismic Zone-III		
Response Spectrum Analysis of Elevated Intze Tank		
Node Numbers	Displacements in mm	
	full	empty
747	29.349	5.830
743	61.547	12.168
714	93.194	18.173
11	114.964	22.328
31	121.516	23.637

Seismic Zone-V		
Response Spectrum Analysis of intze Tank		
Node Numbers	Displacements in mm	
	full	empty
747	66.035	13.117
743	138.983	27.379
714	209.687	40.889
11	258.668	50.233
31	273.412	53.265

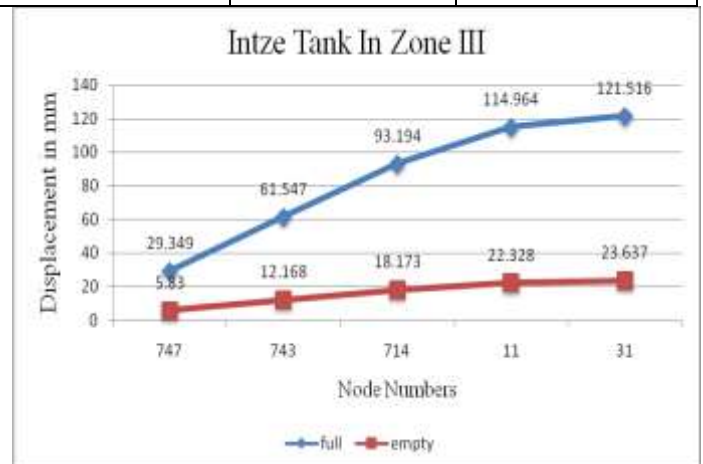

Chart 3: Displacements in Intze Tank in zone III

Seismic Zone-III		
Response Spectrum Analysis of Elevated Circular Tank		
Node Numbers	Displacements in mm	
	full	empty
409	6.292	8.791
401	12.766	8.421
381	19.064	7.002
31	23.311	4.779
11	24.824	2.388

Table 6: Displacements in Circular Tank in zone III

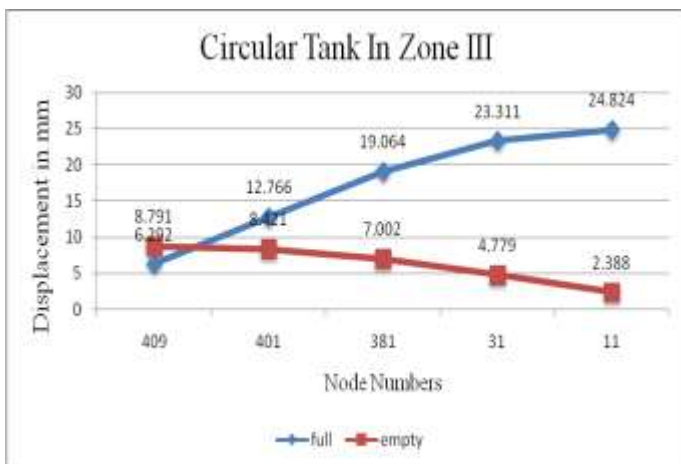

Chart 4: Displacements in Circular Tank in zone III

Table 7: Displacements in Intze Tank in zone V

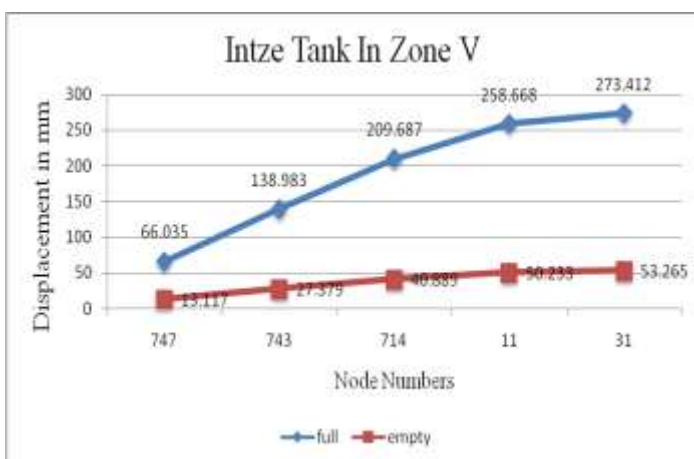

Chart 5 Displacements in Intze Tank in zone V

Seismic Zone - V		
Response Spectrum Analysis of Circular Tank		
Node Numbers	Displacements in mm	
	full	empty
409	31.259	5.375
401	63.411	10.752
381	94.688	15.755
31	115.761	18.946
11	120.637	19.780

Table 8: Displacements in Circular Tank in zone V

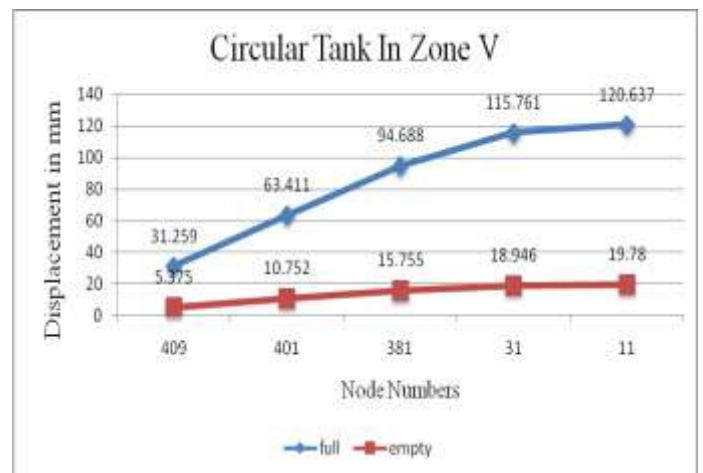

Chart 6: Displacements in Circular Tank in zone V

4.2.1 Discussion On The Nodal Displacements On The Models.

1. The maximum displacement usually occurs at top most nodes and minimum at the bottom supports node for all models irrespective of shape.
2. The displacement increases 4.85 times for the circular tank in full tank condition when Zone III is changed to Zone V.
3. The displacement increases 2.25 times for the Intze tank in full tank condition when Zone III is changed to Zone V.

5. CONCLUSIONS

1. Base shear of full water tank and empty water tank are increased with seismic zone III & V because of zone factor, response reduction factor etc. while considering seismic analysis.

2. Base shear in full tank condition is slightly higher than empty tank due to absence of water or hydro static pressure.
3. Displacement of full water tank and empty water tank are increased with seismic zone III & V because of zone factor, response reduction factor etc. while considering seismic analysis.
4. Minimum nodal displacement and Maximum nodal displacement found at the wall of water tank when tank is in full tank condition.
5. The maximum displacement occurs in Intze tank in comparison with circular tank in both seismic zones III and seismic zone V.
6. The maximum displacement in circular and Intze tank occurs in full tank condition and displacement value increases in zone V in comparison to zone III.
7. As per element property wise the economical water tank is square water tank but as per the analysis the suitable design is recommended for Intze Water Tank
8. Design of elevated water tanks are very complex which involves lot of mathematical calculations and time consuming. Hence Staad pro gives all parameters which are useful in design of elevated water tank.
8. Nitesh J Singh¹, Mohammad Ishtiaque, Design Analysis & Comparison Of Intze Type Water Tank for Different Wind Speed and 5 seismic Zones as Per Indian Codes International Journal of Research in Engineering and Technology, eISSN: 2319-1163, Volume: 04 Issue: 09 | September-2015.
9. Issar Kapadia, Purav Patel, Nilesh Dholiya, Nikunj Patel (2017) "Analysis and Design of INTZE Type Overhead Water Tank under the Hydrostatic Pressure as Per IS: 3370 & IS: 456 -2000 by Using STAAD Pro Software". International Research Journal of Engineering and Technology (IRJET) e-ISSN: 2395-0056, Volume: 04 Issue: 07 | July-2017.
10. Ankush N. Asati, Dr. Mahendra S.Kadu "Seismic Investigation of RC Elevated Water Tank for Different Types of Staging Patterns" International Journal of Engineering Trends and Technology (IJETT) - Volume 14 Number 1 - Aug 2014

BIOGRAPHIES



Name- Aleemuddin Tirandaz
P.G Student, Civil Engineering
Department, VTU University,
SECAB Institute of Engineering and
technology Vijayapur. Karnataka

REFERENCES

1. IS -3370 1967 code of practice Storage of Liquids
2. I.S:456-2000. Indian Standard Code of Practice for Reinforced Concrete.
3. I.S 1893 (Part I) -1984, "Criteria for Earthquake Resistant Design of Structures".
4. S.S. Bhavikatti, Advanced R.C.C Design Volume II 2nd Edition, New Age International Pvt Ltd.
5. 875 (2002) - "Code of Practice for Design Load" Bureau of Indian Standard, New Delhi.
6. STAAD Pro. 2007, Structural Analysis and Design programming-2007 for analysis of lateral stiffness
7. Rajkumar, Shivaraj and Prof. Mangalgi "Response-Spectrum Study Of High-Rised Intze and Circular Water Tanks" International Research Journal of Engineering and Technology (IRJET) eISSN: 239-0056, Volume: 04 Issue: 10 | October-2017.